



Part No. **ALL54150**
ALL54152

Throttle Bell Cranks

Designed for Sprint car applications, each bell crank is fitted with a pressed .250" I.D. bearing for smooth throttle operation and has optional locations for connecting push rods of various lengths. Typically two are required to complete an application. Option holes on each crank are .188" and spaced 3/8" apart.

ALL54150
Arms of bell crank are set 75 degrees from each other.
Aluminum construction, total weight 35 grams.

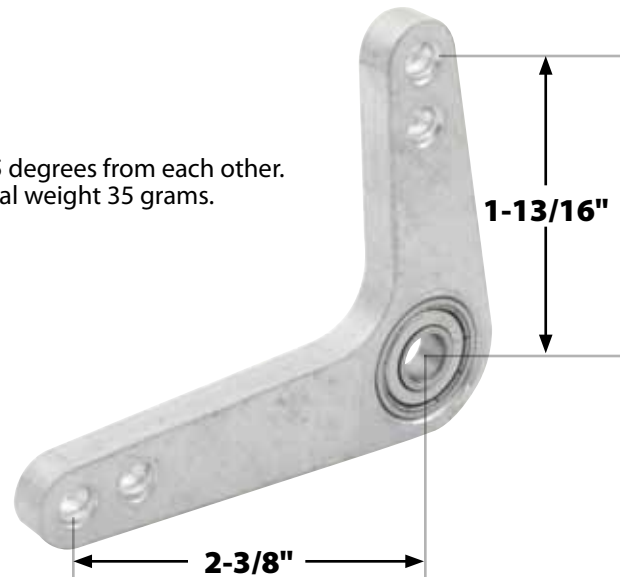

ALL54152
Arms of bell crank are set 70 degrees from each other.
Aluminum construction, total weight 40 grams.