

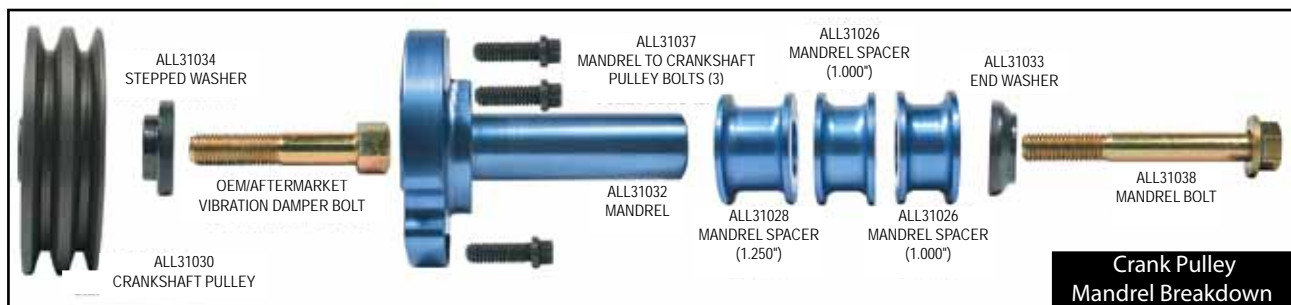

Part No. ALL31031

Crank Pulley Mandrel Kit

Kit prevents mandrel bolt breakage and is made specifically for use with Allstar ALL31030 crank pulley. Mandrel is attached to the crankshaft pulley with three bolts, while the vibration damper is retained with the stock bolt. The mandrel bolt is then connected to the mandrel – not to the crankshaft – to reduce engine harmonics (helps prevent loosening or breaking). Kit includes spacers, pulley guides, and bolts to work effectively with most 3, 4, and 5 stage Dry Sump Pumps, alone or with belt driven fuel pumps. Pulleys sold separately.



Replacement Parts:

- ALL31032.....Crank Pulley Mandrel
- ALL31033.....Mandrel End Washer
- ALL31034.....Stepped Washer
- ALL31035.....Pulley Guide
- ALL31036.....Mandrel Key, 1/8"
- ALL31037.....Mandrel Bolt, 5/16" -18 x 1" (3-Pack)
- ALL31038.....Mandrel End Bolt, 1/2" -13 x 4"

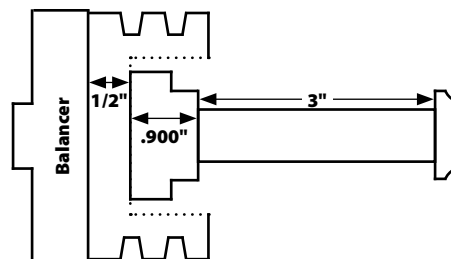

REV071816

Accept no compromises, choose only quality performance engine parts.