

POWER STEERING PUMP & MOTOR MOUNT

404L

Small Block Chevy - Short Water Pump
1955 to '57 passenger cars
1955 to '59 trucks

This bracket is designed to be used with the non-metric Chevrolet pump with attached reservoir. These pumps were first used about 1961 and are still used in a few applications. Most pre 1969 V-8 pumps have a single groove pulley attached with a nut, while the later V-8 pumps can have either a single or double groove pressed on pulley. Either style may be used. Most short water pump applications use a crankshaft p.s. Pulley that bolts over the existing pulley. This will align with the p.s. Pump pulley. This pulley is available from G.M. as part number - 3751232 or from us.

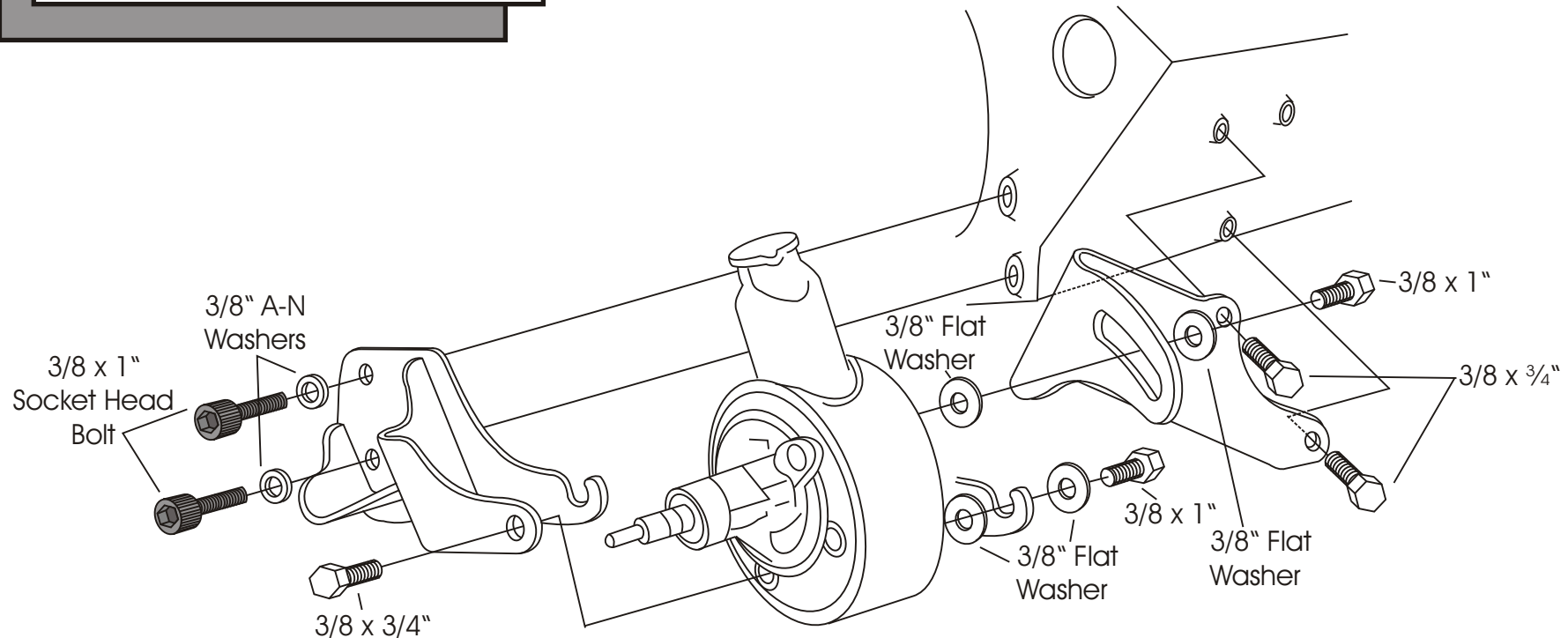

NOTE: If your pump has a stud at the lower rear pivot point, it must be removed and the 1" bolt and 3/8" flat washers used..

We use a belt length of 38½ - 39" with this mount on installations in our shop. However; this can vary with the diameter of your pulleys.

NOTE: This bracket must be used with a '58 or later block with the side motor mount castings.

As with any part of this nature, make sure it fits your application before painting or plating. Parts that have been painted, plated, or modified may not be returned.