



## Installation instructions

Akrapovič Exhaust System:

**Slip-On**

for the

**Chevrolet Corvette Stingray** (type C7)

**Congratulations on purchasing an Akrapovič exhaust system. Please read the entire installation manual prior to undertaking any activities related to installation of your new Akrapovič exhaust system. In case you do not fully understand the manual or any of its parts, please contact your authorized dealer!**

**This product should be installed by someone with sufficient knowledge of exhaust systems and their installation, and appropriate hand or power tools. If you are not qualified for this work, please utilize a certified mechanic for installation. By installing Your Akrapovič exhaust system, you indicate that you have read the installation manual in its entirety and you agree with the terms stated herein.**

**It is your responsibility to follow all installation instruction guidelines supplied with the Akrapovič exhaust system and undertake all necessary safety precautions. Akrapovič d.d. assumes no responsibility for damages occurring from misuse, abuse, improper installation, improper operation, lack of responsible care, or all previously stated reasons resulting from incompatibility with other manufacturer's products and/or systems.**

## **IMPORTANT INFORMATION**

### **Exclusion of Certain Liability**

1. The manufacturer, importer or dealer shall not be liable for any incidental damage including personal injury or any other damages caused by improper installation or operation of the Akrapovič exhaust system. When installing the Akrapovič exhaust system be careful that the exhaust system does not touch other parts sensitive to high temperature.
2. Akrapovič makes no representation or warranties with regard to damage caused by the improper installation, use and maintenance of the Akrapovič exhaust system. The warranty is limited to defects recognized by our technical department and due to normal use, and excludes items subject to normal wear (gaskets and damping wool). The guarantee is void in case of accident, modification, improper or competition use.
3. Do not attempt to install the Akrapovič exhaust system on a vehicle model for which it was not made or tested by Akrapovič.
4. When the exhaust system gets very hot during operation, be careful not to burn yourself on the exhaust system or parts which are in direct contact with it, even when the engine is not running. Also protect other people, especially children, from the injuries mentioned above.

1. In some cases Akrapovič exhaust system kits contain chemical products (ceramic anti-seizing grease; bolt sealant). Handle with care, do not inhale or swallow. Avoid excessive contact with skin, eyes or mucous membranes. Keep out of reach of children.
2. Technical specifications of Akrapovič exhaust systems and related products are subject to change without notice.
3. Before removing the original exhaust system from your vehicle, please compare the parts you received with the list of materials provided in the installation manual in order to assure that you have all the parts necessary for the installation of your new Akrapovič exhaust system.
4. Although this manual consists of instructions for installation in written form, as well as photographs and pictures representing individual steps of the installation, please note that the photographs and pictures are symbolic and are intended for representation of general overview only. The photographs and pictures contained herein should serve as a guideline only and actual installation of the exhaust system may not correspond with the photographs and pictures entirely.
5. The process of uninstalling the original exhaust system may vary depending on the existing exhaust system. Please follow the original exhaust system manufacturer's instructions for uninstalling the original exhaust system.

### **Trademarks**

The Akrapovič trademark, including corporate logos and emblems, are subject to copyright as well as trademark rights of Akrapovič, its licensors or third persons authorizing Akrapovič to use them.

## Symbols

The following symbols are used throughout these installation instructions:



**TOOLS REQUIRED**



**TIGHTENING TORQUE**



**INSTALLATION TIP**



**CAUTION OR WARNING**



**USE BOLT SEALANT;** Apply 3 to 4 small drops of bolt sealant onto the cleaned and degreased threads before tightening the bolts. **WARNING! Avoid contact with skin, eyes and mucous membranes. Do not inhale fumes. Keep out of the reach of children.**



**USE ANTI-SEIZE LEAD-FREE COPPER PASTE** (black tube); Provides trouble-free and long-lasting protection against seizing, corrosion and rusting of bolts, threaded ends, nuts, joints, etc. Also protects against vibration, wear and impact. **WARNING! Avoid eye contact. Avoid excessive skin contact. Keep out of reach of children.**



**USE ANTI-SEIZING GREASE** (white tube); Prevents seizing, corrosion and excessive wear between the titanium components of your exhaust system. **WARNING! Avoid eye contact. Avoid excessive skin contact. Keep out of reach of children.**



T-handle 7 mm wrench  
T-handle 10 mm wrench  
T-handle 13 mm wrench  
Socket 15 mm



**BEFORE INSTALLING, CHECK SCHEMATIC OF THE EXHAUST SYSTEM! THE LATEST VERSION OF THE PARTS LIST AND SCHEMATIC DRAWINGS OF THE PRODUCTS ARE AVAILABLE ON OUR WEB PAGE.**



**IF ANY ITEMS IN THE AKRAPOVIČ EXHAUST SYSTEM PACKAGE ARE MISSING, PLEASE CONTACT YOUR AUTHORIZED DEALER. KEEP THE SCHEMATIC FOR FUTURE REFERENCE.**



**THESE INSTALLATION INSTRUCTIONS MUST BE READ CAREFULLY IN ORDER TO ENSURE PROPER INSTALLATION AND OPERATION OF THE AKRAPOVIČ EXHAUST SYSTEM.**



**THE EXHAUST SYSTEM CAN BE EXTREMELY HOT. ALLOW THE EXHAUST AND ENGINE TO COOL DOWN BEFORE BEGINNING INSTALLATION.**



**WE ADVISE YOU TO LEAVE INSTALLATION TO A QUALIFIED SERVICEMAN. IMPROPER INSTALLATION MAY RESULT IN A SHORTER LIFETIME OF THE EXHAUST SYSTEM AND/OR DAMAGE TO THE VEHICLE.**



**THIS MANUAL IS SPECIFIC TO THE CHEVROLET CORVETTE STINGRAY C7 COUPE. THERE MAY BE SOME DIFFERENCES IN INSTALLATION PROCEDURES FOR OTHER C7 MODELS.**



**WHEN INSTALLING AKRAPOVIČ'S AFTERMARKET OPTIONAL DOWN PIPES WITHOUT CATALYTIC CONVERTERS, WHICH ARE DEVELOPED FOR USE ON CLOSED TRACKS ONLY, REMAPPING OF THE ECU IS MANDATORY. THE AKRAPOVIČ COMPANY TAKES NO RESPONSIBILITY FOR ECU REMAPPING OR ANY POTENTIAL ISSUES RELATED TO THE USE OF AKRAPOVIČ DOWN PIPES.**

## **REMOVAL OF STOCK EXHAUST SYSTEM:**

Put the vehicle onto a car lift.

**!** **WARNING:** ensure that the car is lifted safely and properly in order to avoid the risk of vehicle damage, injury, or even death!

1. Unscrew the marked bolts on both sides of the rear bumper (Figure 1).

**!** **CAUTION:** make sure not to injure yourself or damage any part of the vehicle during this process!



Figure 1

2. Remove the marked grill and reflector on both sides of the bumper (**Figure 2**).

! **CAUTION:** make sure not to injure yourself or damage any part of the vehicle during this process!



Figure 2

3. Unscrew the marked bolts on both sides of the rear bumper (Figure 3).

! **CAUTION:** make sure not to injure yourself or damage any part of the vehicle during this process!



Figure 3



4. Unscrew the marked bolts and carefully remove the lower part of the rear bumper off the vehicle (**Figure 4**).

**!** **CAUTION:** make sure not to injure yourself or damage any part of the vehicle during this process!



**Figure 4**

5. Loosen the marked clamps (**Figure 5**).

! **CAUTION:** make sure not to injure yourself or damage any part of the vehicle during this process!



Figure 5

6. Unscrew the mufflers' connection bolts and mufflers' rubber brackets off the chassis (**Figure 6**).
- ! **CAUTION:** make sure not to injure yourself or damage any part of the vehicle during this process!



Figure 6

7. Disconnect the exhaust valve servos' connectors and carefully remove the mufflers off the vehicle (**Figure 7**). **For vehicles with NPP stock exhaust system:** disconnect all four exhaust valve servos'.
- ! **CAUTION:** make sure, that car key is in OFF position, before you disconnect the connectors! Wait for complete extinction of the car before disconnecting the actuators (1 min after key OFF)!
  - ! **WARNING:** do not put the car key in ON position or start the car, before all connectors are connected again. Risk of check light on the dashboard!



**Figure 7**

8. Unscrew and remove the chassis reinforcement (**Figure 8**).

! **CAUTION:** make sure not to injure yourself or damage any part of the vehicle during this process!

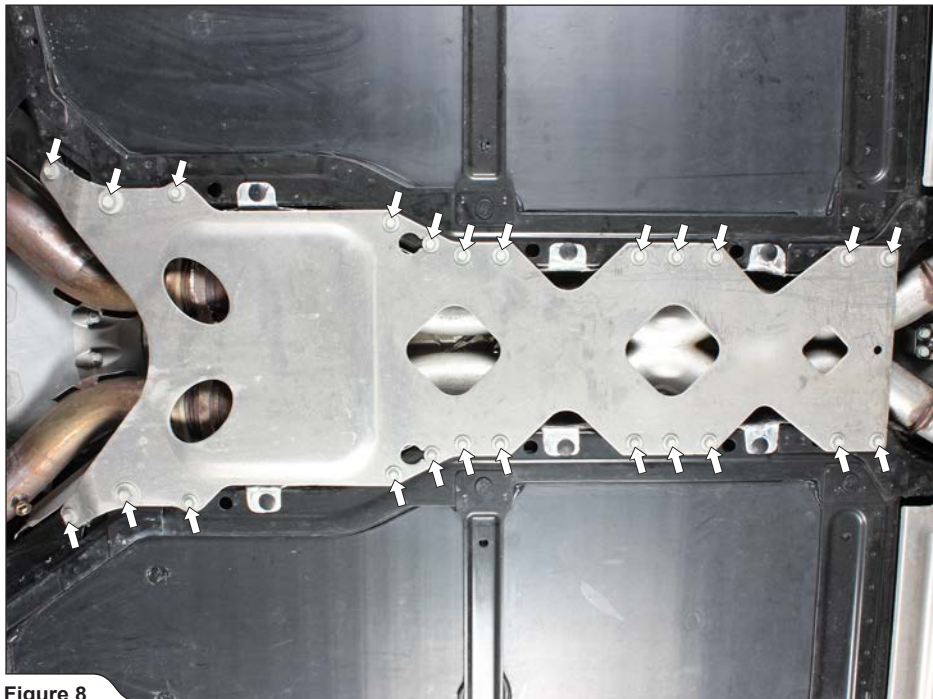

Figure 8

9. Support the link pipes, unscrew the marked flanges' nuts and rubber bracket off the chassis; carefully remove the link pipes off the vehicle (**Figure 9, 10**).

! **CAUTION:** make sure not to injure yourself or damage any part of the vehicle during this process!

! **WARNING:** support the link pipes during this process or you could injure yourself or damage the vehicle!



Figure 9



Figure 10

10. Mark the stock link pipes' outlets exactly as shown. Carefully cut the pipes at the marked cutting lines, using pipe cutting tool or equivalent (**Figure 11, 12, 13**).

**!** **CAUTION:** make sure not to injure yourself or damage any part of the vehicle during this process!

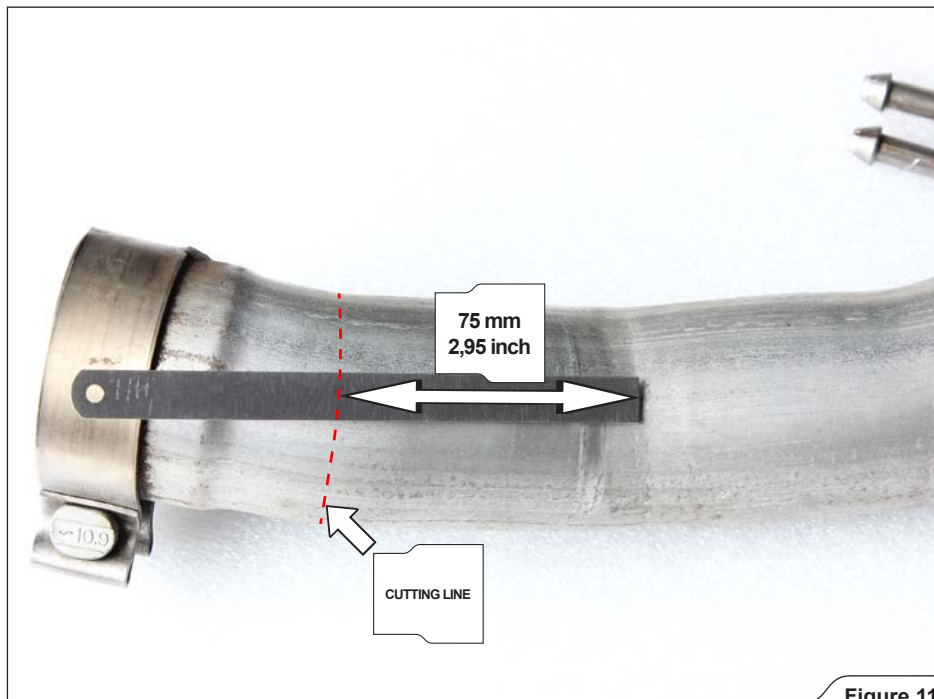

**Figure 11**



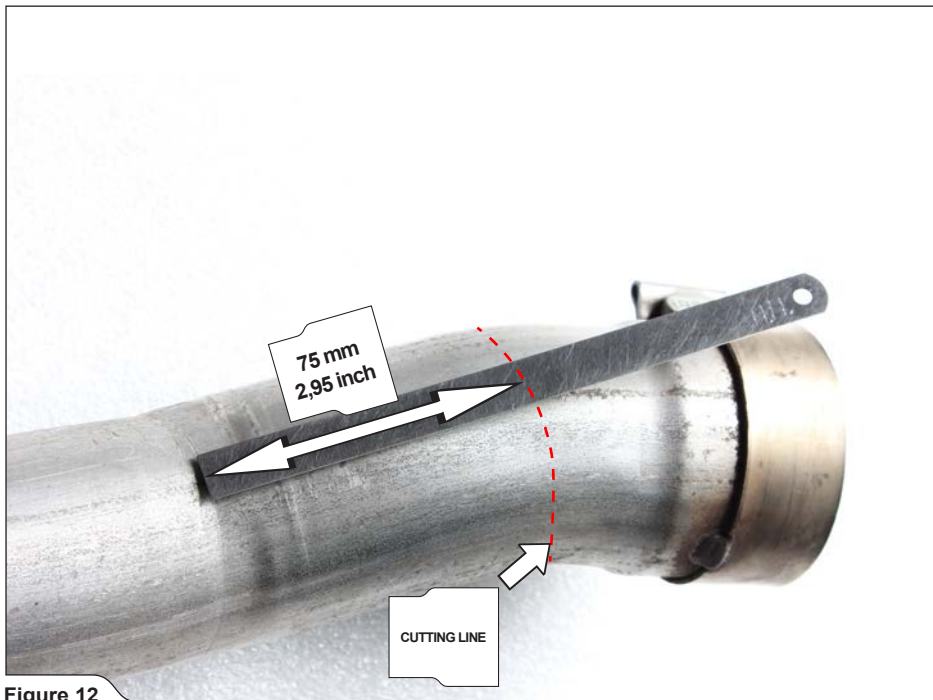

Figure 12

11. Unscrew the exhaust valve servos and carefully remove the rubber brackets off the mufflers (Figure 13, 14). For vehicles with NPP stock exhaust system: unscrew all four exhaust valve servos.

! **CAUTION:** make sure not to injure yourself or damage any part of the vehicle during this process!

✂ **INSTALLATION TIP:** for easier dismounting, lubricate the original rubber brackets (WD40).



Figure 13



Figure 14

## **INSTALLATION OF THE AKRAPOVIČ EXHAUST SYSTEM:**

1. Install the stock link pips back onto the vehicle and tighten the flanges' nuts; do not bolt the link pipes' rubber bracket onto the transmission yet (**Figure 15**).

**✂** **INSTALLATION TIP:** use new exhaust gaskets in link pipes - stock down-pipes joints.

**!** **CAUTION:** make sure not to injure yourself or damage any part of the vehicle during this process!

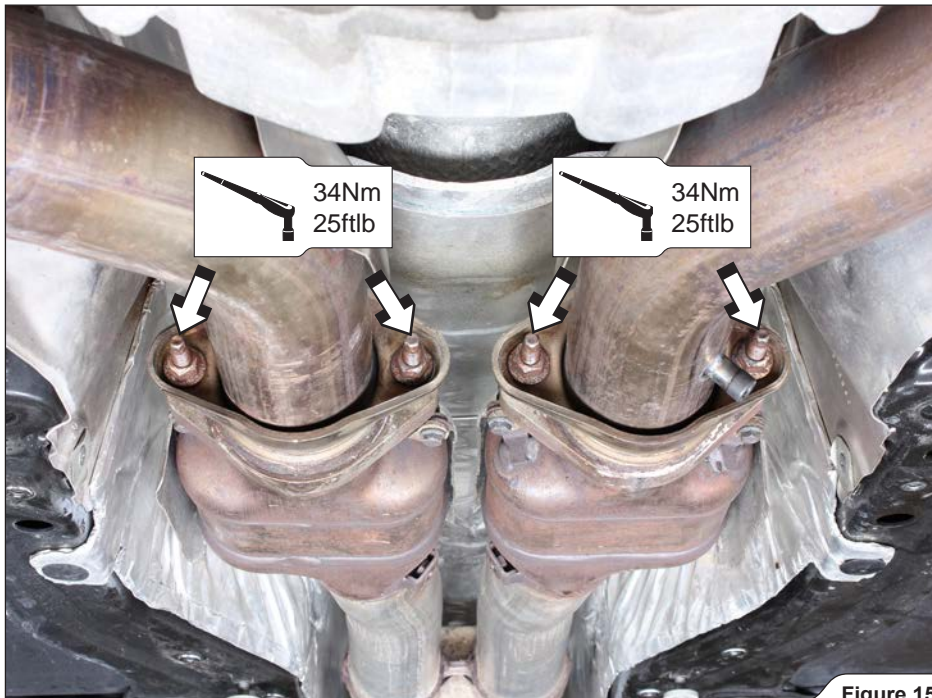

**Figure 15**

2. Reinstall the chassis reinforcement (Figure 16).

! **CAUTION:** make sure not to injure yourself or damage any part of the vehicle during this process!

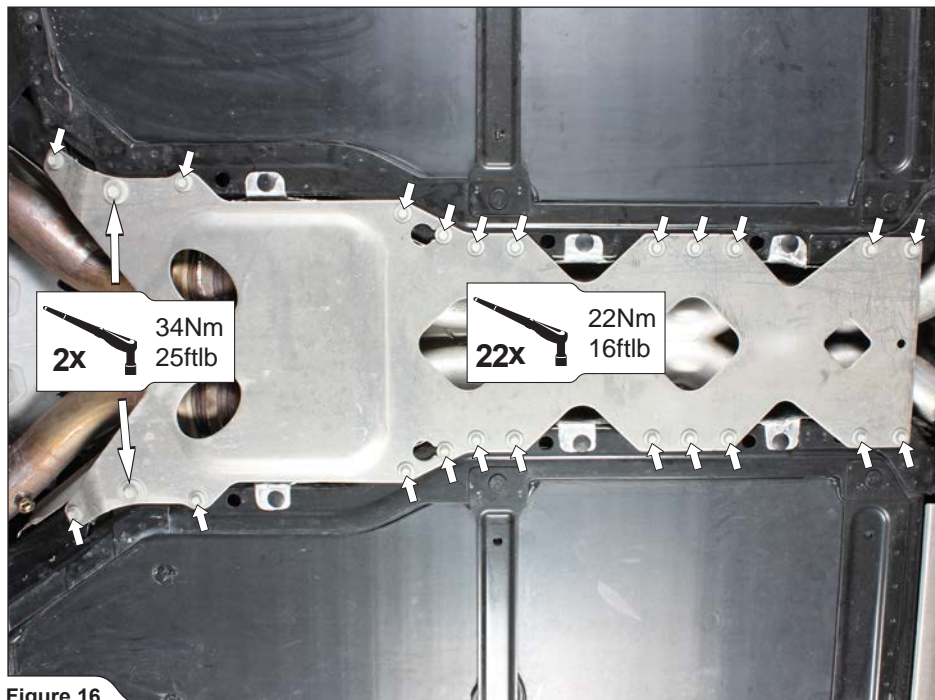

Figure 16

3. Correctly orient and attach the clamps onto the adapters and slide them onto the link pipes outlets, as shown (Figure 17, 18).

**!** CAUTION: hand tighten the clamps only; do not fully tighten them yet!



Figure 17

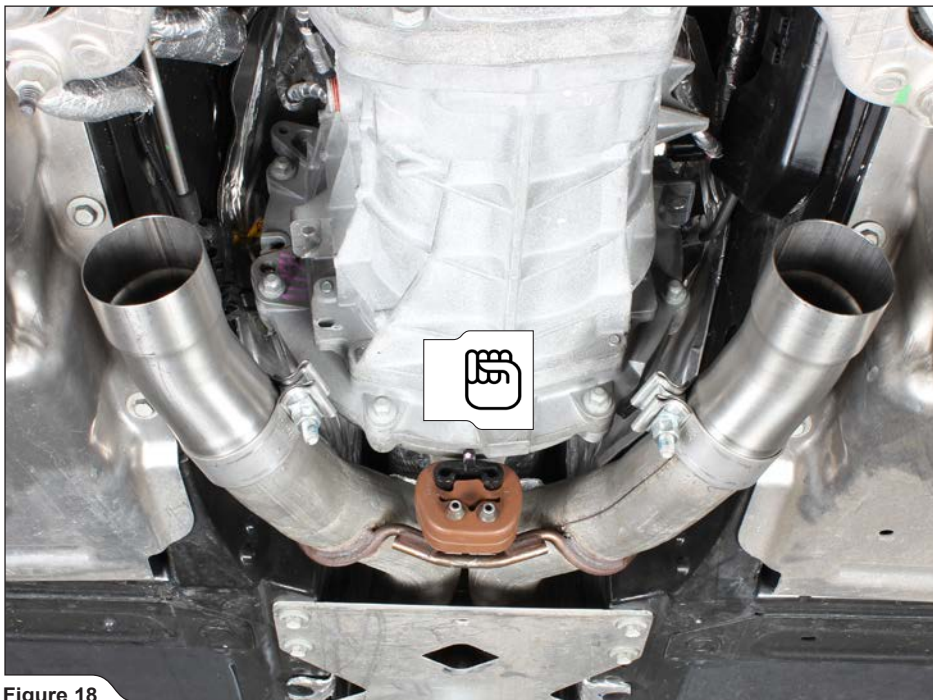

Figure 18

4. Assemble the two stock exhaust valve actuators and two additional actuators from Akrapovič installation kit (**For vehicles with NPP stock exhaust system:** use all four stock actuators), stock rubber brackets and clamps onto the Akrapovič mufflers, as shown (**Figure 19, 20, 21, 22**).

! **CAUTION:** make sure not to injure yourself or damage the valves or actuators during this process!

✂ **INSTALLATION TIP:** for easier mounting, lubricate the original rubber brackets (WD40).



Figure 19





Figure 20

**! CAUTION: use Akrapovič bolt sealant on all bolts' threads (Figure 21)!**



**Figure 21**

**!** CAUTION: hand tighten the clamps only; do not fully tighten them yet (Figure 22)!



**Figure 22**

- Slide the mufflers onto the adapters, reconnect the exhaust valve servos' connectors and hand tighten the clamps (**Figure 23, 24**). **For vehicles with NPP stock exhaust system:** reconnect all four exhaust valve servos' connectors.

**!** **CAUTION:** make sure not to injure yourself or damage any part of the vehicle during this process!



**Figure 23**

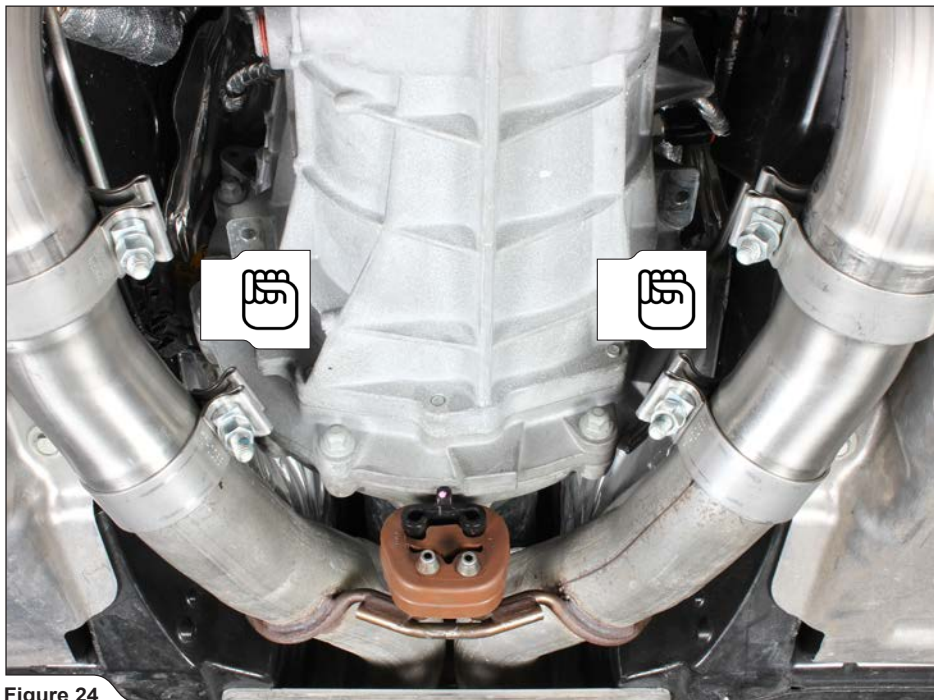
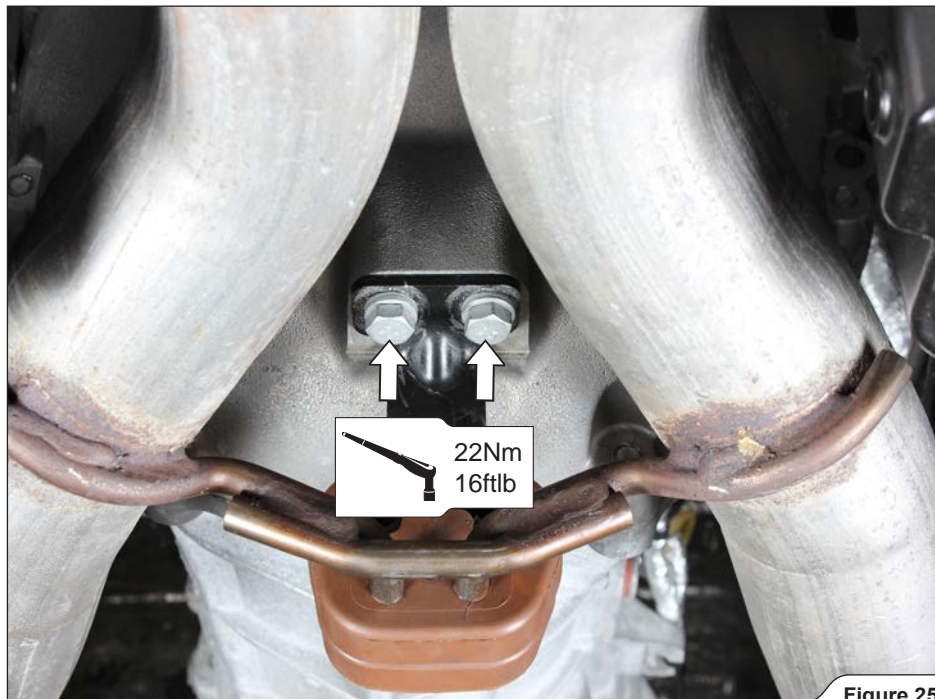

Figure 24

6. Attach the link pipes bracket onto the transmission and tighten the mufflers' rubber brackets onto the chassis (**Figure 25, 26**).

!

**CAUTION:** make sure not to injure yourself or damage any part of the vehicle during this process!



**Figure 25**

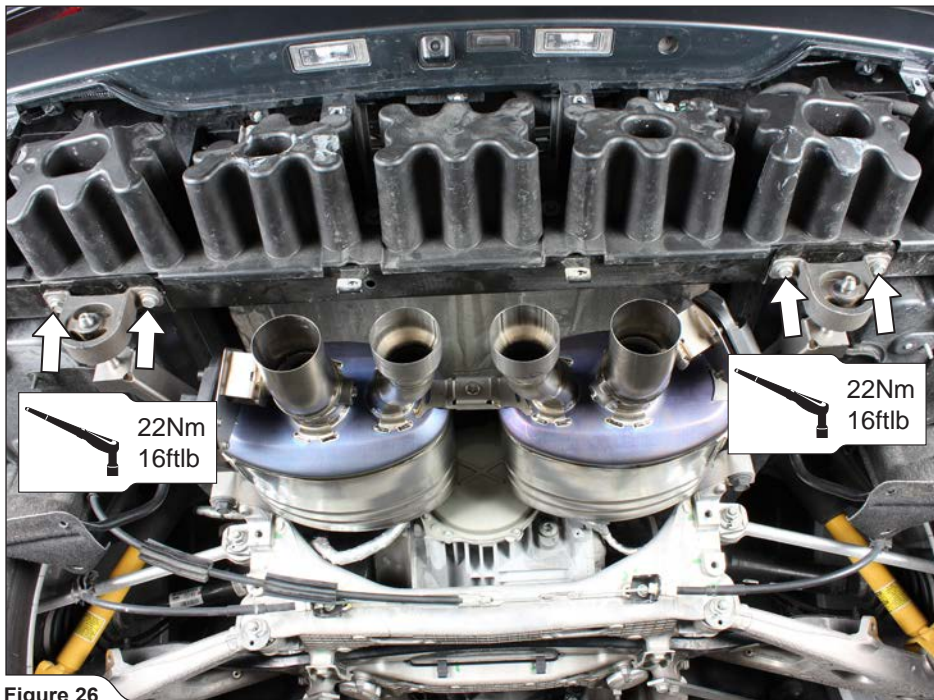
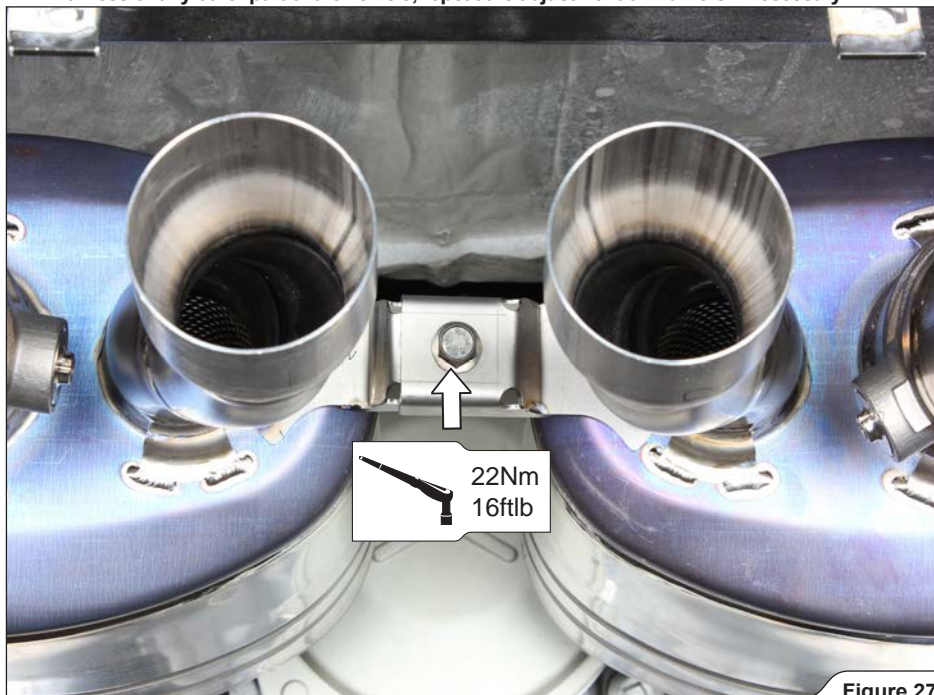

Figure 26

7. Adjust and center the mufflers, tighten the muffler connection (using bolt, washer and nut from Akrapovič installation kit) and all adapter clamps to the specified torques (**Figure 27, 28**).

! **CAUTION:** make sure not to injure yourself or damage any part of the vehicle during this process!

! **CAUTION:** make sure, that any part of the exhaust system isn't touching the chassis, electrical harness or any other part of the vehicle; repeat the adjustment of mufflers if necessary!



**Figure 27**



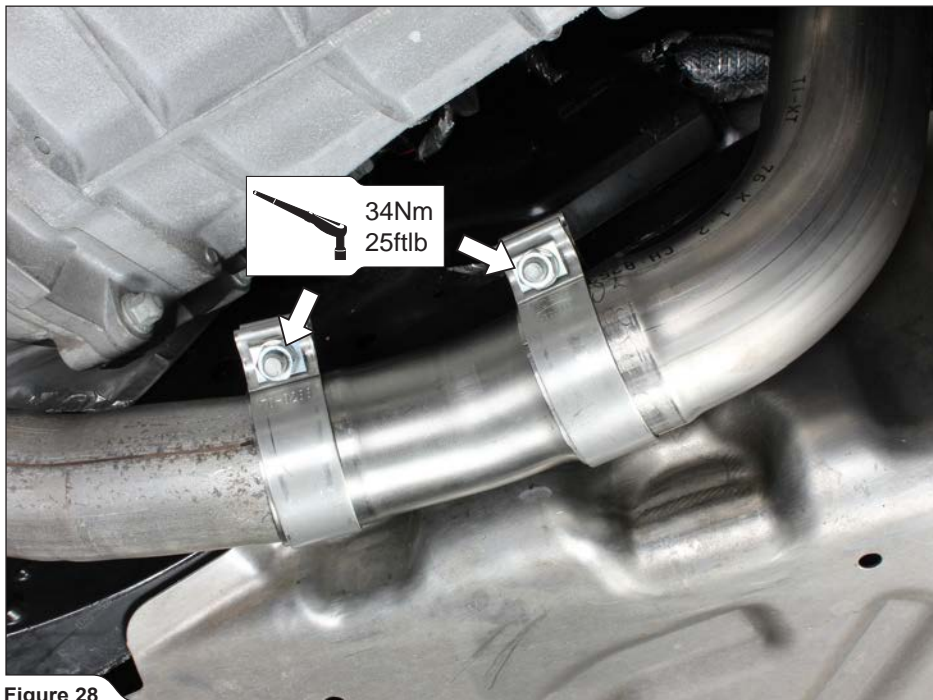

Figure 28

8. **For vehicles with standard stock exhaust system:** install the Akrapovič Control Kit - check the Control Kit installation manual for correct installation.
  9. Replace all dismantled stock parts (rear bumper) in the reverse order from the order in which they were removed. Check vehicle manufacturer manual for tightening torques.
- !** **CAUTION: make sure not to injure yourself or damage any part of the vehicle during this process!**
10. Assemble the clamps and spherical rings onto the tail pipes (**Figure 29**).
- !** **CAUTION: make sure not to damage the tail pipes during this process!**



**Figure 29**

11. Slide the tail-pipes onto the muffler outlets. Rotate and center them in respect to rear bumper and according to your personal preference (**Figure 30, 31**).

**!** **CAUTION:** make sure, not to damage tail pipes, bumper or any part of the vehicle during this process!



Figure 30

The image shows the Akrapovič logo, which consists of an orange stylized 'A' symbol followed by the brand name 'AKRAPOVIČ' in a bold, italicized, black sans-serif font. Below the logo is a close-up view of a black exhaust manifold with four circular exhaust ports. Each port has a small Akrapovič logo on its rim. The entire scene is set against a plain white background.

**AKRAPOVIČ**

Figure 31

12. Tighten tail pipe clamps to the specified torque (**Figure 32**).



Figure 32

## Final installation:

- ! **WARNING: check vehicle manufacturer manual for tightening torques (for dismantled stock parts)!**
- ! **WARNING: make sure all the nuts and bolts are sufficiently tightened. In case the exhaust system touches the cowling or other parts, repeat the adjustment of the exhaust system or contact your authorized dealer.**

## **MAINTENANCE OF THE AKRAPOVIČ EXHAUST SYSTEM:**

1. Clean the titanium exhaust components with a multi-purpose spray lubricant (WD-40 or equivalent), carbon fiber exhaust components with soft and dry cloth and stainless steel components with soft cloth sprayed with contact cleaner, then wipe with soft and dry cloth. A change in the color of the exhaust system is normal due to high temperatures.
2. Periodically make sure all the bolts and springs are sufficiently tight.

- ! **WARNING: clean all exhaust components before the first start of the engine or the stains will burn onto the surfaces!**
  
- ! **IT IS NORMAL FOR WHITE SMOKE TO COME OUT OF THE MUFFLER AT FIRST OPERATION.**
- ! **DO NOT STAND BEHIND THE MUFFLER AT FIRST OPERATION.**
- ! **DO NOT USE AUTOMOTIVE WHEEL CLEANERS OR ANY CLEANING PRODUCTS WHICH CONTAIN ACIDIC ADDITIVES TO CLEAN THE AKRAPOVIČ EXHAUST SYSTEMS.**

## **WARNING**

Please note that certain aftermarket exhaust systems may not comply with applicable California laws and regulations, and may therefore be prohibited for use on California highways or roads, or on roads or vehicles otherwise subject to emissions control requirements.

Akrapovič exhaust systems for automobiles and motorcycles mounted downstream of the catalytic converter (also known as “cat-back systems”) are considered “replacement parts” in California by the California Air Resources Board (CARB), and do not require an exemption or executive order from CARB to be sold in California. However, California prohibits the use of any aftermarket exhaust system that modifies, removes or replaces original equipment catalysts, unless CARB has issued an Executive Order as to such part or system.

Further, Akrapovič parts or exhaust systems used or intended for use on “racing vehicles” (i.e. a competition vehicle used exclusively for competition on closed-course circuits) do not require an exemption or Executive Order from CARB to be sold in California. However, such parts are prohibited from use on California public highways or roads, even if occasionally used “off-road.”