

## Notice

90% of all Air Tool problems are caused by  
*moisture* in air lines

This problem can be avoided by using Air Tool Lubricant  
(See "Lubrication" & "Air Supply" sections of this manual)

**FAILURE TO OIL** can void your warranty



Angle Die Grinder  
Model # 6255 /Composite

*Operating Instructions, Parts List,  
Warranty, & Warranty Repair Centers*

**IMPORTANT!** Read carefully before operating this tool. Failure to operate any power tool properly can result in personal injury and/or property damage!

### SPECIFICATIONS

Sound-----	82DBA	Free Speed(RPM)-----	20,000
Air Flow Pressure(PSI)-----	90	Avg. Air Consump.(cfm)-----	9.5
Hose Size(ID)-----	3/8"	Shipping Wt. (LBS)-----	1.3
Air Inlet(NPT)-----	1/4"		

### Safety

1. Read all instructions before operating your tool
2. Always wear protective eye gear. Use a dust mask if the operation creates dust.
3. Wear gloves and protective clothing to avoid injuries caused by malfunctioning attachments or improperly clamped work.
4. Never use the tool over 90 psi, its free speed will increase in proportion to any increase in air pressure above 90 psi.
5. **USE ACCESSORIES ON THIS TOOL.**
6. **DISCONNECT TOOL FROM AIR SUPPLY BEFORE CHANGING ANY ACCESSORY ON THIS TOOL.** Do not perform service work on tool while connected to air supply.
7. If a sudden change occurs in the feel or sound of the unit, the tool should be immediately turned off and head inspected for damage.
8. Handle the tool safely. Do not carry the tool with a finger on or near the throttle or trigger while the tool is connected to the air supply. Do not carry the tool by the hose. Protect the hose from sharp objects and heat.
9. **When not in use, disconnect tool from air supply to prevent accidental or unauthorized use.**
10. Always use tool a safe distance from other people in work area.
11. Do not attempt to alter any part of this tool in any way, shape or form.

### Lubrication

Lubricate daily with good grade of air tool oil. Lubricate motor before using. In in-line lubricator is not used, add a few drops of oil into air inlet daily. Do not flood this tool with oil. **GREASE HEAD GEARS DAILY.**

## Air Supply

Tools of this class operate on a wide range of air pressure. It is recommended that air pressure of these tools measures **90 PSI** at the tool while running free. Higher pressure and unclean air will shorten the tool's life because of faster wear and may create a hazardous condition and void the warranty.

Water in the air line will cause damage to the tool. Drain the air tank daily. Clean the air inlet filter screen on at least a weekly schedule. The recommended hookup procedure can be viewed in the illustration below.

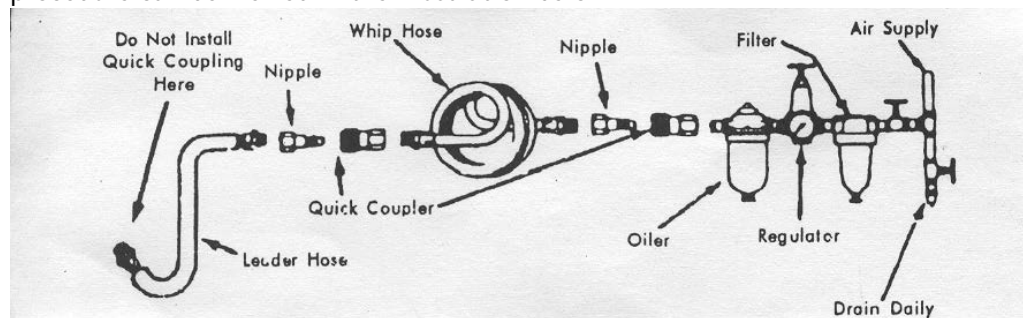

The air inlet, used for connecting air supply, has standard 1/4" NPT American Thread.

Line pressure should be increased to compensate for unusually long air hoses (over 25 feet). Minimum hose diameter should be 3/8" I.D. and fittings should have the same inside dimensions.

## Operating Instructions

1. Read safety instructions first.
2. The tool is started by depressing the throttle, which is spring loaded and when released returns to off position.
3. Always wear protective safety goggles and clothing when operating tool.
4. **DO NOT, UNDER ANY CIRCUMSTANCES, REMOVE THE DISC GUARD.**
5. Use both hands when operating this tool.
6. Refer to safety instructions when operating this tool.

## Maintenance

Other factors outside the tool may cause loss of power or erratic action. Reduced compressor output, excessive drain on the air line, moisture or restriction in air pipes or the use of hose connections of improper size or poor condition may reduce air supply. Grit or gum deposits in the tool may cut power and may be corrected by cleaning the air strainer and flushing out the tool with gum solvent oil or an equal mixture of SAE#10 oil and kerosene. If outside conditions are in order and tool is out-of-warranty, disconnect tool from hose, disassemble tool, replace worm or damaged parts, clean, reassemble, and re-lubricate, or take tool to any air tool service center. For tools in warranty period, send tool direct to Warranty Center. *You must send in your warranty card for warranty service.*

**AIRCAT®**  
PNEUMATIC TOOLS

Angle Die Grinder  
Model # 6255 /Composite

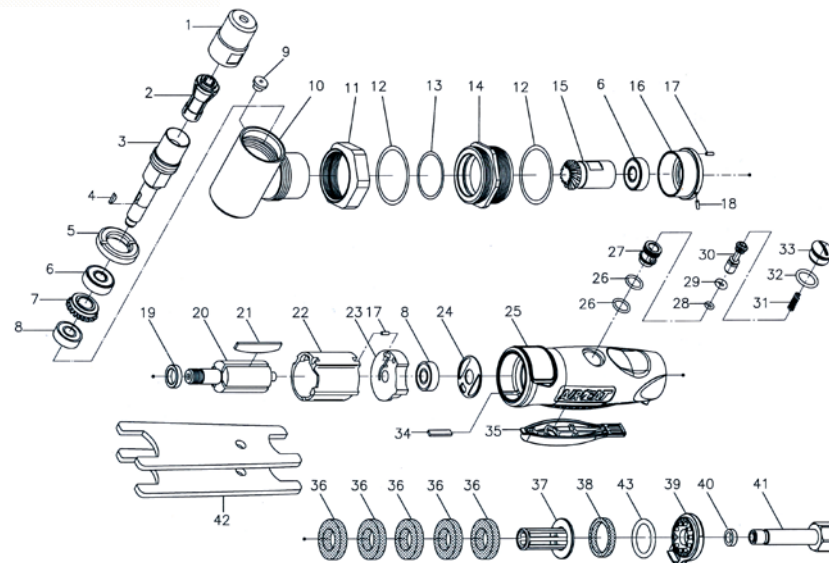

Ref. No.	Part No.	Description	Q'ty	Ref. No.	Part No.	Description	Q'ty
1	501A-001	Collets Nut	1	23	221-023	Rear End Plate	1
2	511-002B	Collets 1/4"	1	24	222F-045	Rear Gasket	1
3	501A-003	Spindle	1	25	222F-025	Motor Housing	1
4	00-3701	Key	1	26	00-4167	O-Ring	2
5	501A-002	Angle Housing Nut	1	27	222F-026	Bushing	1
6	00-2332	Ball Bearing	2	28	00-41187	O-Ring	1
7	501A-009	Spiral Bevel Gear	1	29	00-41157	O-Ring	1
8	00-2340	Ball Bearing	2	30	222F-027	Valve Stem	1
9	00-4605	Grease Fitting	1	31	222F-029	Spring	1
10	501A-004	Angle Housing	1	32	00-4166	O-Ring	1
11	501A-005	Nut	1	33	222F-030	Valve Plug	1
12	00-4177	O-Ring	2	34	222F-037	Seal Lump	1
13	00-4158	O-Ring	1	35	222F-043	Throttle Lever	1
14	502FA-006	Clamp Nut	1	36	222F-038	Muffler	5
15	501A-008	Spiral Bevel Gear	1	37	222F-039	Exhaust Tube	1
16	501-019	Front End Plate	1	38	222F-047	Muffler	1
17	00-3333	Spring Pin	2	39	222F-042	Exhaust Deflector	1
18	00-3334	Spring Pin	1	40	222F-050	Bushing	1
19	501-006	Spacer	1	41	222F-034C	Air Inlet	1
20	501-020	Rotor	1	42	411-034	Double Ended Wrench	2
21	221-021	Rotor Blade	4	43	00-4173	O-Ring	1
22	221-022	Cylinder	1				

Discover other air tools and compressors on our website.