



Installation Instructions

For Part Numbers:

200-763 850-030 Airaid Oiled Media Filter

201-763 851-030 SynthaMax Dry Media Filter - Red

2017-19 CHEVROLET / GMC

Colorado / Canyon

L4-2.5L

NOT LEGAL FOR SALE OR USE ON ANY POLLUTION CONTROLLED MOTOR VEHICLE IN CALIFORNIA OR STATES ADOPTING CALIFORNIA EMISSION PROCEDURES.

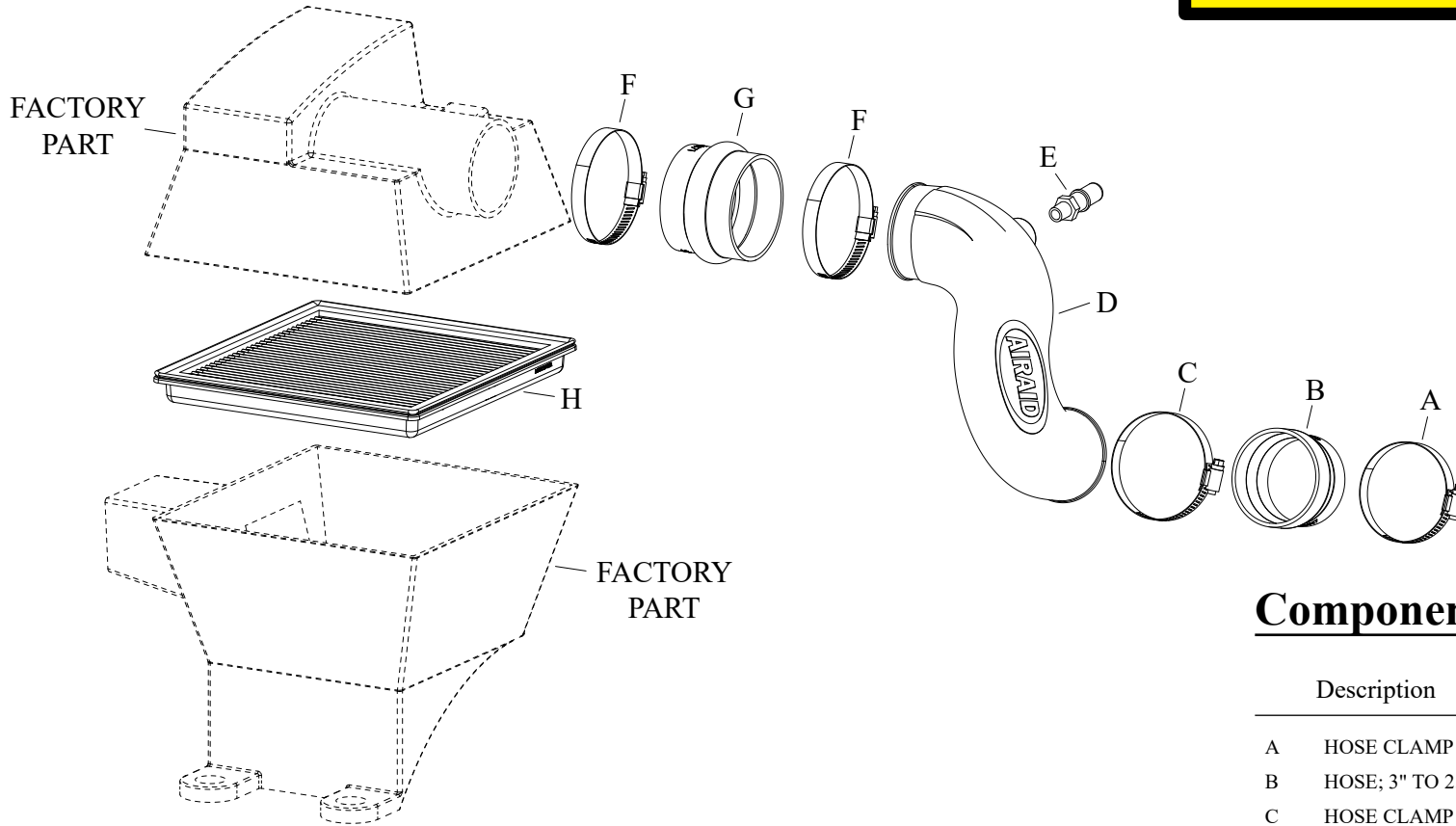

TOOLS NEEDED:

Flat blade screw driver
Ratchet
Extension
10mm wrench

Component Identification

Description	Qty.	Part #
A HOSE CLAMP #44 STAINLESS	1	08560
B HOSE; 3" TO 2.75"ID X 2"L	1	084036
C HOSE CLAMP #48	1	08601
D INTAKE TUBE	1	KIT763
E VENT; 1/4 NPT QUICK	1	082628
F HOSE CLAMP #52	2	08610
G HOSE; HUMP 3.25"ID X 2-5/8"L	1	08171
H FILTER	1	850/851-030

TO START:

1. Turn off the ignition and disconnect the negative battery cable.

NOTE: Disconnecting the negative battery cable erases pre-programmed electronic memories. Write down all memory settings before disconnecting the negative battery cable. Some radios will require an anti-theft code to be entered after the battery is reconnected. The anti-theft code is typically supplied with your owner's manual. In the event your vehicles anti-theft code cannot be recovered, contact an authorized dealership to obtain your vehicles anti-theft code.



2. Loosen the hose clamps that secures the intake tube to the air filter housing and to the throttle body.



3. Disconnect the crank case vent line from the intake plenum and remove the bolt that secures the plenum to the engine. Remove the intake tube and plenum from the vehicle.

NOTE: AIRAID recommends that customers do not discard factory air intake.



4. Loosen the four bolts that secure the upper air filter housing to the lower housing, remove the housing and factory air filter.



5. Install the AIRAID® air filter and then reinstall the upper housing and secure with the factory screws.



6. Install the provided coupler hose (084036) onto the throttle body and secure with the provided hose clamp.

Continued...



7. Install the provided vent fitting into the AIRAID® intake tube as shown.

NOTE: Plastic NPT fittings are easy to cross thread. Install the vent fitting “hand” tight, then turn it two complete turns with a wrench.



8. Install the provided coupler (08171) onto the air filter housing and secure with the provided hose clamp.



9. Install the intake tube into the coupler at the throttle body, align with the coupler on the air filter housing. Adjust the tube for best fit and secure with the provided hose clamps. Reconnect the mass air sensor electrical connection.



10. Double check your work!

Make sure there is no foreign material in the intake path. Make sure all clamps, hoses, bolts, and screws are tight. Double check the hood clearance!

Reconnect the negative battery cable!

850-030 Airaid Oiled Media

FILTER IDENTIFICATION

851-030 Airaid SynthaMax Dry Media - Red

For your Oiled media filter we offer the Airaid Tune Up Kit!



P/N 790-551 Aerosol Spray
P/N 790-550 Squeeze Spray



NOT LEGAL FOR SALE OR USE ON ANY POLLUTION CONTROLLED MOTOR VEHICLE IN CALIFORNIA OR STATES ADOPTING CALIFORNIA EMISSION PROCEDURES.

SynthaMax

Synthamax Air Filters do not require oil. Service air filter as needed by cleaning with common non-petroleum all-purpose household cleaner and water. Simple Green®, Formula 409® or equivalent works great. Apply cleaner to outside of air filter and allow to soak. Then flush filter clean from the inside out with a garden hose and repeat steps if necessary. Do not apply high pressure water or air to clean filter. Allow filter to air dry and reinstall.

Shop for quality Airaid products on our website.

Learn more about performance air intake systems we have.