



Installation Instructions

For Part Numbers:

450-211	700-469 Airaid Oiled Media Filter
451-211	701-469 SynthaMax Dry Media Filter - Red
452-211	702-469 SynthaMax Dry Media Filter - Black
453-211	703-469 SynthaMax Dry Media Filter - Blue

2007-09 Ford Mustang Shelby GT Supercharged 5.4L V8

INTAKE SYSTEMS FOR VEHICLES LISTED ARE 50 STATE LEGAL. SEE CARB STATUS ON EACH PART FOR A SPECIFIC VEHICLE.

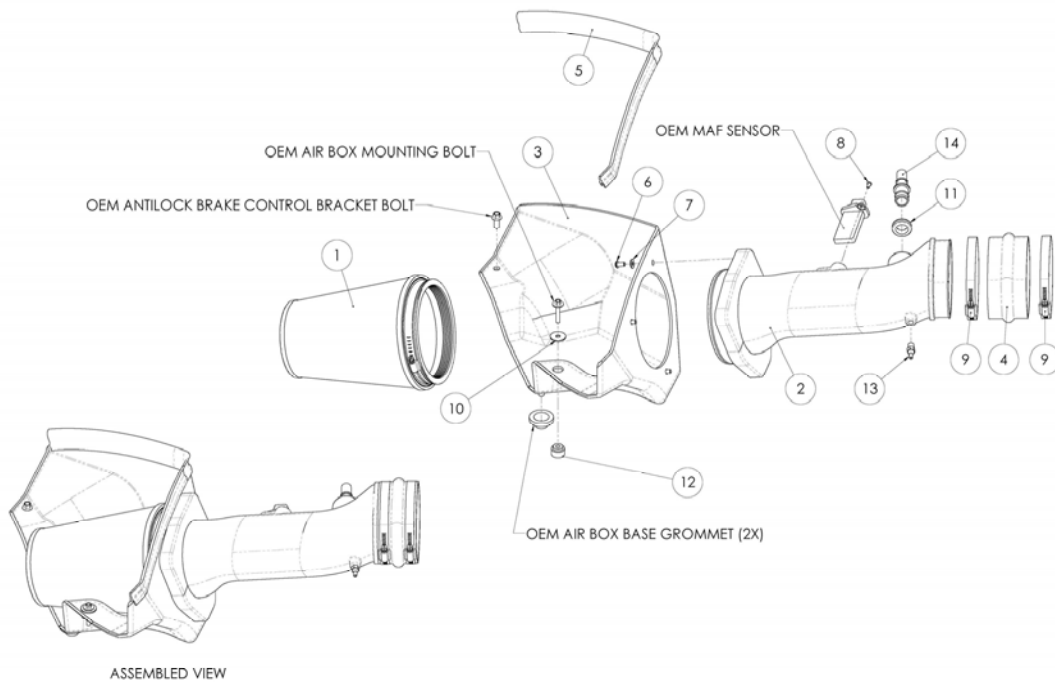

Component Identification

1.	Airaid Premium Filter	1
2.	Airaid Intake Tube	1
3.	Cool Air Dam	1
4.	Oval Hump Hose	1
5.	Weather Strip 25 1/2"	1
6.	1/4-20x1/2" Button Head Bolt	3
7.	1/4" Flat Washer	3
8.	8-32x3/8" Button Head Screw	2
9.	#80 Hose Clamp	2
10.	1/4" Fender Washer	1
11.	Grommet	1
12.	Aluminum Spacer	1
13.	1/8"NPT x 3/16" Barbed Fitting	1
14.	Aluminum Fitting	1
15.	#20 Torx Bit	1

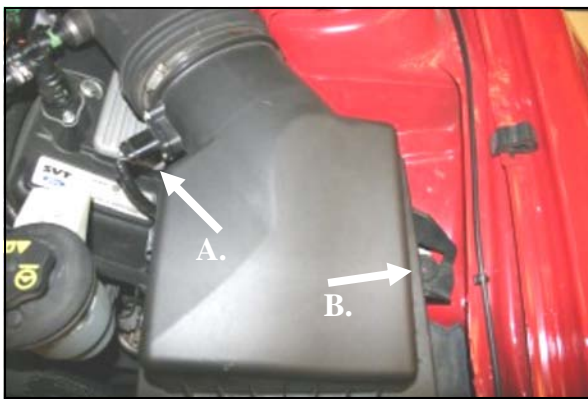

1. **Disconnect the negative battery cable.**
A.) Slide out the RED locking tab on the bottom of the Mass Air Flow sensor (MAF) connector, and then squeeze the BLACK tab and disconnect the connector from the sensor. B.) Using a 10mm socket, remove and save the bolt that holds the air filter box to the inner fender. It will be reinstalled in step #13.

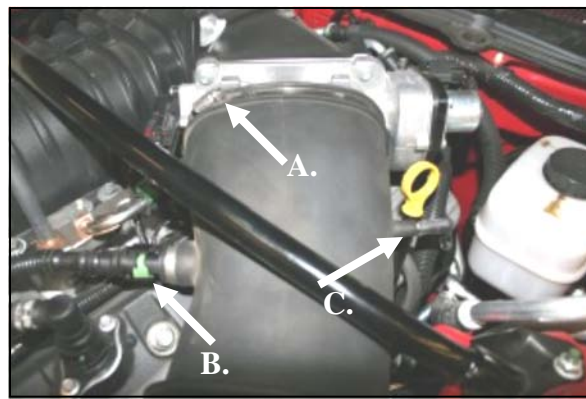

2. A.) Loosen the factory intake tube hose clamp on the throttle body. B.) Push the GREEN tab on the breather hose connector and disconnect it from the factory intake tube. C.) CAREFULLY disconnect the vacuum line from the factory intake tube.



3. Remove the complete factory intake system from the vehicle.



4. Remove the two factory grommets from the bottom of the factory airbox and replace them back into the holes in the inner fender. They will be used to guide the Airaid Cool Air Dam to the correct location in the vehicle.



5. Using the provided #20 torx bit, remove two factory screws and the Mass Air Flow sensor from the factory airbox lid. Note the direction of the sensor for proper re-installation later. (Save the mass air sensor for re-installation in step #9, the factory screws will not be re-used).



6. Using a 10mm socket, remove and save the bolt from the top of the anti-lock brake bracket. It will be re-installed later in step #13.

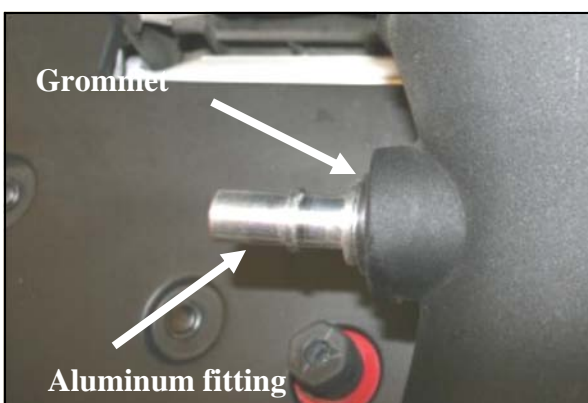

7. Install the provided grommet (#11) into the large hole in the side of the Airaid Intake Tube (#2). Next, carefully install the supplied aluminum fitting (#14) into the grommet as shown.



8. Install the 1/8"NPT x 3/16" barbed fitting (#13) into the small threaded hole in the side of the Airaid Intake Tube.



9. Install the Mass Air Flow sensor removed in step #5, into the Airaid Intake Tube **using the provided 8-32 x 3/8" button head screws (#8)**. Make sure the arrow on the sensor is pointing towards the throttle-body.
Do Not Use The Factory Screws!

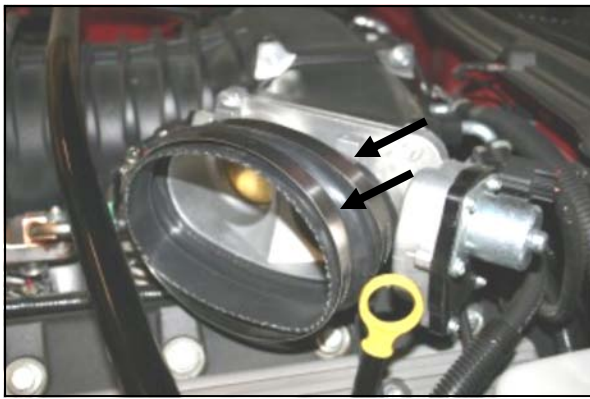

10. Install the oval hump hose (#4) onto the throttle body with two provided #80 hose clamps (#9). Leave the clamps loose for now.



11. Install the Airaid Intake Tube into the oval hump hose. For ease of installation, don't tighten the clamps yet!



12. Slide the Aluminum Spacer (#12) underneath the CAD and into the hole as shown. Secure the CAD to the inner fender using the OEM bolt from step #1 and the supplied 1/4" Fender Washer (#10).



13. Install the Cool Air Dam into the vehicle aligning the grommet posts on the bottom of the CAD into the factory grommets in the fender well. Now install three 1/4" button head bolts (#6) and flat washers (#7) thru the CAD and into the Airaid Intake Tube. Next reinstall the second factory bolt from step #6 into its respective hole.



14. Install the Airaid Premium Filter (#1) onto the Airaid Intake Tube and tighten the hose clamp. Next install the supplied weather strip (#5) onto the top of the CAD as shown. For ease of installation, start next to the radiator and work your way towards the fender.



15. Adjust the Airaid Intake Tube for fit and then tighten the hose clamps on the throttlebody and the tube. Now reconnect the wiring harness to the MAF, the breather to the aluminum fitting, and the vacuum hose to the barbed fitting on the Airaid Intake Tube.

16. Double check your work!

Make sure there is no foreign material in the intake path. Make sure all clamps, hoses, bolts, and screws are tight. Double check the hood clearance!

17. Reconnect the negative battery cable!

Thank you for purchasing the Airaid Intake System. Your Airaid Intake System was carefully inspected and packaged. Check that no parts are missing, or were damaged during shipping. If any parts are missing, contact Airaid. The air filter element is protected from direct exposure to water and debris; care should be taken not to drive through deep water. WATER INGESTION IS THE DRIVERS RESPONSIBILITY! The air filter is reusable and should be cleaned periodically.

FILTER IDENTIFICATION

700-469 Airaid Oiled Media
702-469 Airaid SynthaMax Dry Media - Black

701-469 Airaid SynthaMax Dry Media - Red
703-469 Airaid SynthaMax Dry Media - Blue

For your Oiled media filter we suggest using the AIRAID Filter Tune-Up Kit!



P/N 790-551 Aerosol Spray
P/N 790-550 Squeeze Spray



Do Not Oil

Synthamax Air Filters do not require oil. Service air filter as needed by cleaning with common non-petroleum all-purpose household cleaner and water. Simple Green®, Formula 409® or equivalent works great. Apply cleaner to outside of air filter and allow to soak. Then flush filter clean from the inside out with a garden hose and repeat steps if necessary. Do not apply high pressure water or air to clean filter. Allow filter to air dry and reinstall.