



Installation Instructions

For Airaid Jr. Part Numbers:

450-745 850-500 Airaid Oiled Media Filter
 451-745 851-500 SynthaMax Dry Media Filter
 And M.I.T. Part Number
 450-945 Airaid Modular Intake Tube only

2011-14 Ford Mustang
 3.7L V6

INTAKE SYSTEMS FOR VEHICLES LISTED ARE 50 STATE LEGAL. SEE CARB STATUS ON EACH PART FOR A SPECIFIC VEHICLE.

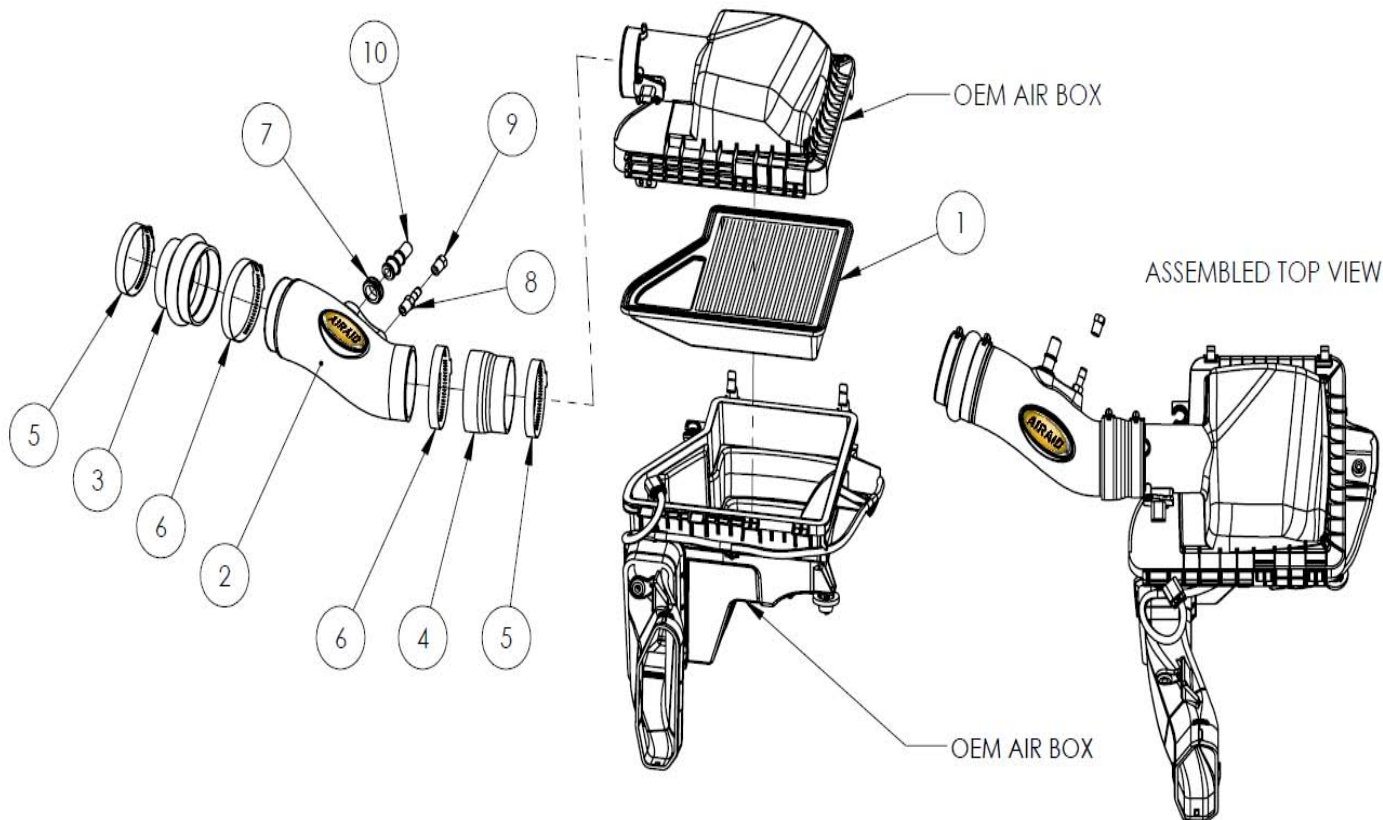

Component Identification

1.	*Airaid Premium Filter	1
2.	Modular Intake Tube	1
3.	Hump Hose	1
4.	Reducer	1
5.	#48 Hose Clamp	2
6.	#52 Hose Clamp	2
7.	5/8" Grommet	1
8.	Barbed Fitting	1
9.	Threaded Plug	1
10.	5/8" Fitting	1
11.	Airaid Decal	1

*Filter Included only in Jr. Kits



1. Disconnect the negative battery terminal.

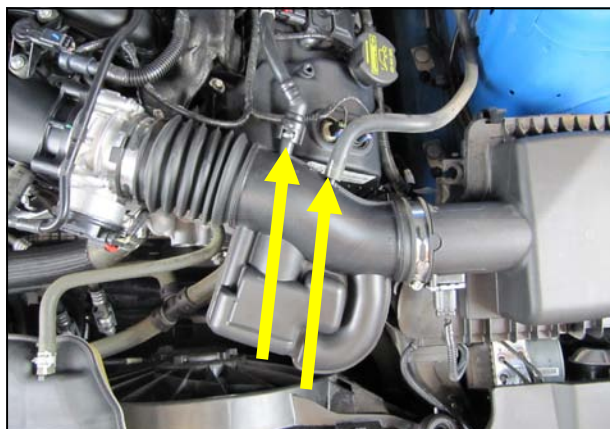

2. Carefully depress the connector lock tabs, and disconnect the crank case breather line and the brake aspirator line if equipped, (AT models only).



3. Loosen the hose clamps on the factory intake tube and remove it.



4. Install the Grommet and Fittings into the Modular Intake Tube as shown. **A)** All models will require the use of the 5/8" Fitting and the 5/8" Grommet. **B)** Automatic transmission equipped vehicles will also use the Barbed Fitting. Apply the Airaid Decal as shown.



5. Manual transmission vehicles will not need the Barbed Fitting and will use the Threaded Plug.



6. Slide the Hump Hose, one #48 Clamp, and one #52 Clamp onto the Intake Tube as shown. Do not tighten the Clamps at this time.



7. Slide the Reducer, one #48 Clamp, and one #52 Clamp onto the other side of the Intake Tube as shown. Do not tighten the Clamps at this time.

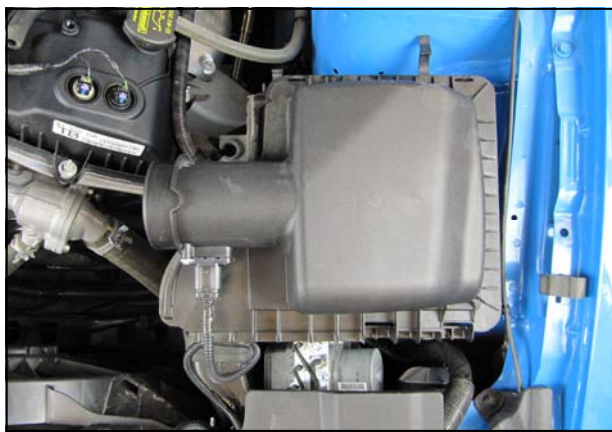

8. Unclip the factory air box lid and slide it off of the tabs in front. If you are installing an Airaid Jr. kit, install the Airaid Premium filter at this time. Leave the air box lid unattached for now.



9. Slide the Tube assembly onto the throttle body.



10. Slide the air box outlet into the Coupler. Connect the breather lines from step 2 to the Airaid Intake Tube. Rotate the tube if necessary to clear the Hood and valve cover and tighten all Clamps.



11. Reattach the air box lid.

Double check your work. Make sure there is no foreign material in the intake path. Make sure all clamps, hoses, bolts, and screws are tight. Reconnect the negative battery terminal.

Thank you for purchasing the Airaid Intake System. Your Airaid Intake System was carefully inspected and packaged. Check that no parts are missing, or were damaged during shipping. If any parts are missing, contact Airaid. The air filter element is protected from direct exposure to water and debris; care should be taken not to drive through deep water. WATER INGESTION IS THE DRIVERS RESPONSIBILITY! The air filter is reusable and should be cleaned periodically.

FILTER IDENTIFICATION

850-500 Airaid Oiled Media

851-500 Airaid SynthaMax Dry Media

For your Oiled media filter we suggest using the AIRAID Filter Tune-Up Kit!

SynthaMax[®]

Do Not Oil



P/N 790-551 Aerosol Spray
P/N 790-550 Squeeze Spray



Synthamax Air Filters do not require oil. Service air filter as needed by cleaning with common non-petroleum all-purpose household cleaner and water. Simple Green®, Formula 409® or equivalent works great. Apply cleaner to outside of air filter and allow to soak. Then flush filter clean from the inside out with a garden hose and repeat steps if necessary. Do not apply high pressure water or air to clean filter. Allow filter to air dry and reinstall.