



Installation Instructions

For Part Numbers:

400-226	720-473 Airaid Oiled Media Filter
401-226	721-473 SynthaMax Dry Media Filter - Red
402-226	722-473 SynthaMax Dry Media Filter - Black
403-226	723-473 SynthaMax Dry Media Filter - Blue

2009-10 Ford F-150 4.6L, 5.4L V8
2008-10 Ford F-250/F-350 Super Duty
5.4L V8, 6.8L V10

INTAKE SYSTEMS FOR VEHICLES LISTED ARE 50 STATE LEGAL. SEE CARB STATUS ON EACH PART FOR A SPECIFIC VEHICLE.

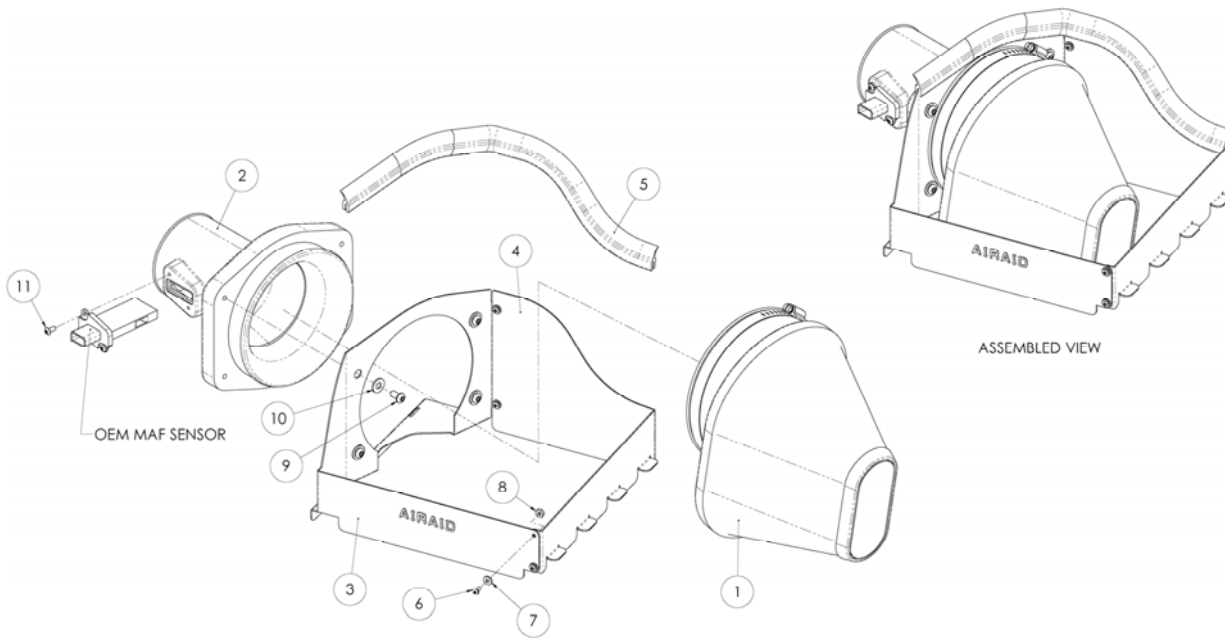

Component Identification

1.	Airaid Premium Filter	1
2.	MAF Adapter Tube	1
3.	Front Panel	1
4.	Rear Panel	1
5.	Weather Strip 16 1/2"	1
6.	6-32x5/16" Screw	4
7.	#6 Flat Washer	4
8.	6-32 Keps Nut	4
9.	1/4-20 Button Head Bolt	4
10.	1/4" Flat Washer	4
11.	8-32x3/8" Button Head Screw	2
12.	#20 Torx Security Bit	1
13.	Airaid Decal	1

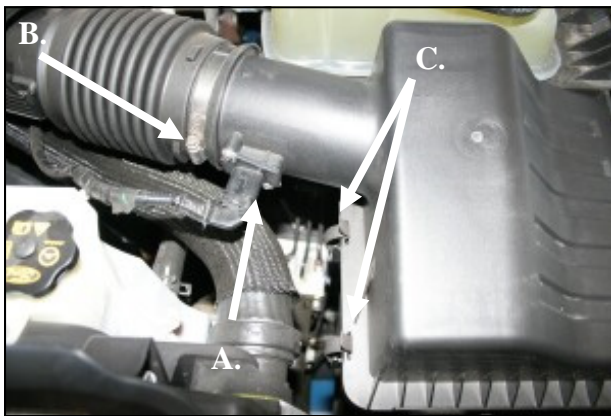

1. Disconnect the negative battery cable!

A.) Using the provided #20 Torx Bit remove two screws and the Mass Air Flow (MAF) sensor from the factory intake tube. There is no need to disconnect the wiring harness.

B.) Loosen the factory hose clamp.

C.) Unlatch 3 clips that secure the airbox lid to the base.



2. Remove the factory airbox lid from the vehicle by sliding the flexible tube off of the airbox lid neck, and then rotate the lid up and out of the base.

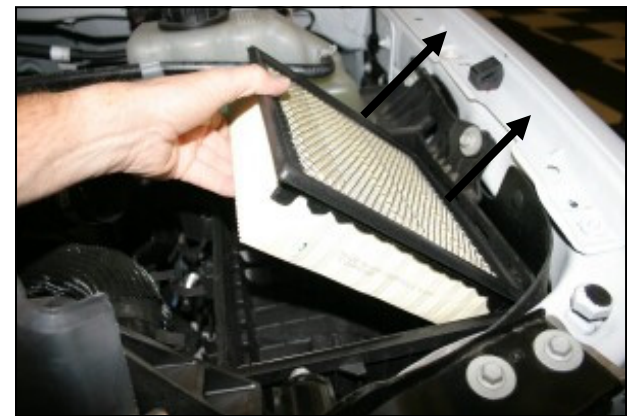

3. Remove the factory air filter from the airbox base.



4. Assemble the two Quick Fit panels (#3 & #4) as shown using four 6-32 screws (#6) flat washers (#7) and keps nuts (#8). Apply the Airaid Decal onto the Panel assembly as shown.

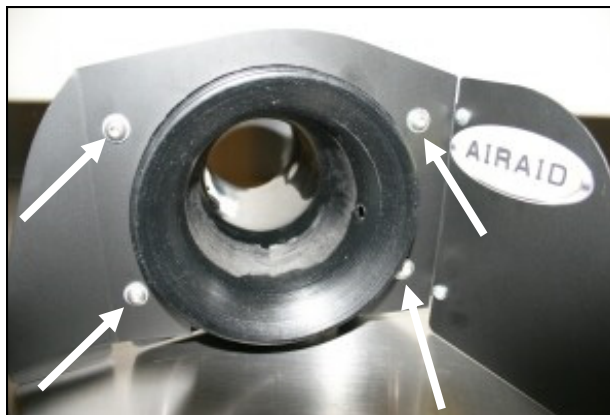

5. Install the MAF Adapter Tube (#2) into the Quick Fit Panel as shown using four 1/4-20 button head bolts (#9) and flat washers (#10). Make sure the slot for the MAF sensor is on the left side when looking from this view.



6. Install the Quick Fit Assembly onto the top of the factory airbox base sliding the four tabs on the panel into the slots on the base and then latching the three factory latches. Slide the factory intake tube over the MAF tube and tighten the factory hose clamp as shown.



7. Reinstall the MAF sensor into the Airaid Adapter Tube using two 8-32 x 3/8" button head screws (#11).
Do Not Use The Factory Screws !



8. Install the Airaid Premium Filter (#1) onto the adapter tube and tighten the hose clamp. Next install the weather strip (#5) onto the top of the Quick Fit panels as shown.

9. Double check your work!

Make sure there is no foreign material in the intake path. Make sure all clamps, hoses, bolts, and screws are tight. intake path. Make sure all clamps, hoses, bolts, and screws are tight. Periodically check the tightness of all hose clamps.

10. Re-connect the negative battery cable!

Thank you for purchasing the Airaid Intake System. Your Airaid Intake System was carefully inspected and packaged. Check that no parts are missing, or were damaged during shipping. If any parts are missing, contact Airaid. The air filter element is protected from direct exposure to water and debris; care should be taken not to drive through deep water. **WATER INGESTION IS THE DRIVERS RESPONSIBILITY!** The air filter is reusable and should be cleaned periodically.

FILTER IDENTIFICATION

720-473 Airaid Oiled Media
722-473 Airaid SynthaMax Dry Media - Black

721-473 Airaid SynthaMax Dry Media - Red
723-473 Airaid SynthaMax Dry Media - Blue

**For your Oiled media filter
we suggest using the
AIRAID Filter Tune-Up Kit!**



**P/N 790-551 Aerosol Spray
P/N 790-550 Squeeze Spray**

SynthaMax[®]

Do Not Oil

Synthamax Air Filters do not require oil. Service air filter as needed by cleaning with common non-petroleum all-purpose household cleaner and water. Simple Green[®], Formula 409[®] or equivalent works great. Apply cleaner to outside of air filter and allow to soak. Then flush filter clean from the inside out with a garden hose and repeat steps if necessary. Do not apply high pressure water or air to clean filter. Allow filter to air dry and reinstall.

