



INTAKE SYSTEMS FOR VEHICLES LISTED ARE 50 STATE LEGAL. SEE CARB STATUS ON EACH PART FOR A SPECIFIC VEHICLE.

Installation Instructions

For Part Numbers:

400-249	700-420 Airaid Oiled Media Filter
401-249	701-420 SynthMax Dry Media Filter - Red
402-249	702-420 SynthMax Dry Media Filter - Black
403-249	703-420 SynthMax Dry Media Filter - Blue

1997-2004 Ford Expedition

1997-2003 F-150 4.6L, 5.4L V8

2004 Ford F-150 Heritage 4.6L, 5.4L V8

Component Identification

1.	Airaid Premium Filter	1
2.	Airaid Intake Tube	1
3.	MAF Panel	1
4.	Bottom Panel	1
5.	Panel Extension	1
6.	MAF Bracket	1
7.	Urethane Hump Hose	1
8.	Urethane Reducer Hump Hose	1
9.	5/8" x 18" Breather Hose	1
10.	3/4" x 12" L-Hose	1
11.	Weather Strip 23"	1
12.	6-32 x 5/16" Phillips Head Screw	9
13.	#6 Flat Washer	9
14.	6-32 Kep Nut	9
15.	1/4-20 x 7/8" Hex Head Bolt	6
16.	1/4" Flat Washer	4
17.	1/4" Nylock Nut	6
18.	MAF Gasket	1
19.	MAF Backing Plate	1
20.	#52 Hose Clamp	1
21.	#60 Hose Clamp	3
22.	#19 Speed Clamp	2
23.	#22 Speed Clamp	2
24.	Rubber Grommet	1

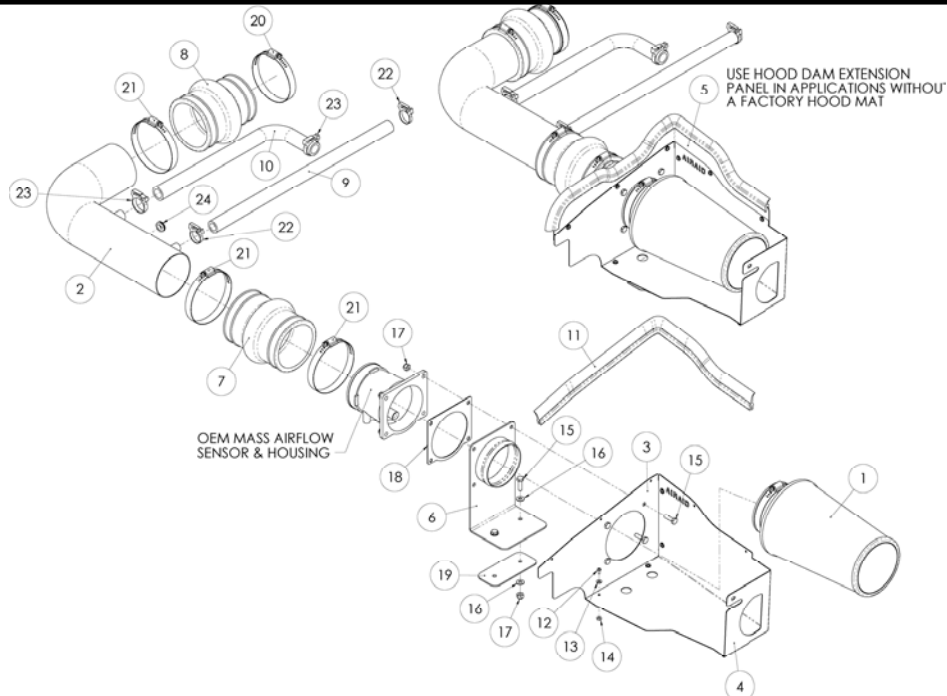

1. **Disconnect the negative battery cable.** Using a 10mm socket, remove the three bolts that secure the beauty cover over the throttlebody. Remove the cover and save these parts for reinstallation in step #16.



2. **A) Very carefully**, using a pulling circular motion, remove the air intake temperature sensor from the air intake tube. **B)** Disconnect the upper hard plastic tube from the air intake tube. **C)** Disconnect the crankcase breather at the intake tube and the valve cover, and remove it from the vehicle. **D)** Loosen two hose clamps and remove the air intake tube from the vehicle.



3. Lift straight up on the outlet side of the air filter canister to remove it from its locating grommets. Next, pull it towards the engine to dislodge it from the inner fender well.



4. Unlatch the clamp on the canister to separate the two halves. Once separated, remove the factory air filter. **A)** Next, slide the large round plastic Mass Air Flow (MAF) sensor adapter plate from the canister. To do this, slide the wires through the rubber grommet to gain access to the MAF sensor wiring connector. Now disconnect the MAF sensor wiring harness, and remove the MAF sensor housing and adapter plate. Remove the remaining half of the canister from the vehicle.

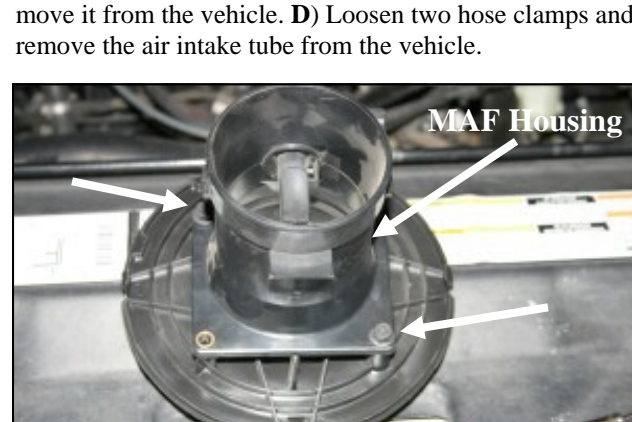

5. Remove the bolts that secure the MAF sensor housing to the adapter. Separate the adapter plate from the MAF sensor housing and save the sensor and housing for reinstallation in step #7.



6. Assemble the MAF panel (#3), and bottom panel (#4) as shown using four 6-32 screws (#12), four flat washers (#13), and four Kep nuts (#14) as shown. Apply the Airaid Foil Decal onto the Panel as shown.

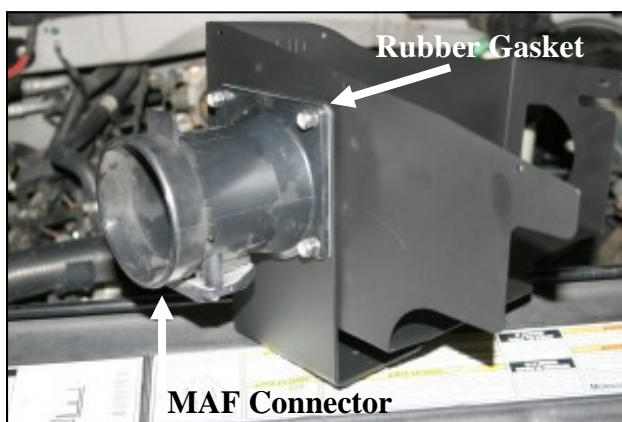

7. Attach the MAF bracket (#6), rubber gasket (#18), and factory MAF sensor housing to the Cold Air Dam (CAD) using four 1/4-20x7/8" hex bolts (#15), and 1/4" Nylock nuts (#17), as shown. Make sure that the MAF sensor connector is on the bottom when assembly is complete. Refer to the line drawing above for reference.



8. Using a 10mm socket, remove and save the bolt that secures the radiator overflow tank to the driver side inner fender well.



9. Remove the two grommets that held the air filter canister in place. They will not be reused.



10. Install the CAD assembly into the vehicle using two 1/4-20x7/8" bolts (#15), four 1/4" flat washers (#16), one MAF backing plate (#19), and two 1/4" nylock nuts (#17). Leave the two bolts slightly loose for now for final adjustment. Refer to the line drawing on page 1 for reference. Next, reinstall the 6mm bolt thru the CAD, radiator overflow tank, and into the fender well. Reconnect the MAF sensor wiring harness.



11. Install the hump hose (#7) onto the MAF sensor housing as shown using two #60 hose clamps (#21). Tighten only the clamp on the MAF sensor housing at this time.



12. Install the small end of the reducing hump hose (#8) onto the throttlebody and tighten the #52 hose clamp (#20). Next, install the remaining #60 hose clamp (#21) on the large end of the hump hose leaving it loose for now.



13. Install the supplied rubber grommet (#24) into the Airaid Intake Tube (#2). Apply the Airaid Decal onto the Intake Tube as shown.



14. Install the Airaid Intake Tube into the hump hose on the MAF, and then into the hump hose on the throttlebody. Adjust for fit, and then tighten the hose clamps. Connect the 5/8"x18" breather hose (#9) between the valve cover and the intake tube as shown using two #19 speed clamps (#22). Now carefully reinstall the intake air temperature sensor into the grommet from step #13. Now that everything is in place, tighten the three bolts that secure the CAD to the vehicle. **5.4L engines:** Measure, and then cut the 3/4"x12" L-hose (#10) and then install it between the hard plastic hose and the intake tube as shown using two #22 speed clamps (#23).

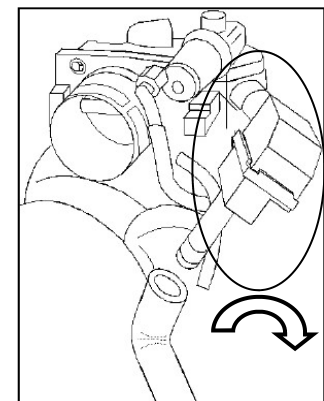

15. 4.6L engines: Rotate the resonator box 90 degrees to provide clearance for the 3/4 x 12" L-hose (#7). Install the 3/4"x12" L-hose (#10) onto the Airaid Intake tube and the resonator box and secure it using the two #22 speed clamps (#23).



16. Reinstall the beauty cover using the 3 factory bolts. Install the Airaid Premium Filter (#1) as shown, and tighten the hose clamp. *If your vehicle does not have a hood mat, skip to Step #17.* Install the weatherstrip (#11) onto the top of the CAD as shown.



17. If your vehicle does not have a hood mat install the optional CAD height extender (#5) using five 6-32 screws (#12), flat washers (#13), and keps nuts (#14) as shown. Install the weatherstrip (#11) onto the top of the CAD as shown.

18. Double check your work! Make sure there is no foreign material in the intake path. Make sure all clamps, hoses, bolts, connectors, and screws are tight. **Reconnect the negative battery cable!**

Thank you for purchasing the Airaid Intake System. Your Airaid Intake System was carefully inspected and packaged. Check that no parts are missing, or were damaged during shipping. If any parts are missing, contact Airaid. The air filter element is protected from direct exposure to water and debris; care should be taken not to drive through deep water. WATER INGESTION IS THE DRIVERS RESPONSIBILITY! The air filter is reusable and should be cleaned periodically.

FILTER IDENTIFICATION

700-420 Airaid Oiled Media
702-420 Airaid SynthaMax Dry Media - Black

701-420 Airaid SynthaMax Dry Media - Red
703-420 Airaid SynthaMax Dry Media - Blue

For your Oiled media filter we suggest using the AIRAID Filter Tune-Up Kit!



P/N 790-551
Aerosol Spray
P/N 790-550
Squeeze Spray



Do Not Oil

Synthamax Air Filters do not require oil. Service air filter as needed by cleaning with common non-petroleum all-purpose household cleaner and water. Simple Green®, Formula 409® or equivalent works great. Apply cleaner to outside of air filter and allow to soak. Then flush filter clean from the inside out with a garden hose and repeat steps if necessary. Do not apply high pressure water or air to clean filter. Allow filter to air dry and reinstall.