



Installation Instructions

For Part Numbers:

200-145	700-469 Airaid Oiled Media Filter
201-145	701-469 SynthaMax Dry Media Filter - Red
202-145	702-469 SynthaMax Dry Media Filter - Black
203-145	703-469 SynthaMax Dry Media Filter - Blue

2002-06 Cadillac Escalade/ESV/EXT
 2002-06 Chevrolet Avalanche 1500
 1999-06 Chevrolet Silverado 1500
 2001-06 Chevrolet Silverado 1500HD/2500HD/3500HD
 2000-06 Chevrolet Tahoe/ Suburban 1500/ Suburban 2500
 1999-06 GMC Sierra 1500
 2001-06 GMC Sierra 1500 HD/2500 HD/3500
 2000-06 GMC Yukon/Yukon XL 1500/Yukon XL 2500
 2007 GMC Sierra "Classic"/Chevrolet Silverado "Classic"
 4.8L V8, 5.3L V8, 6.0L V8 With Mechanical Cooling Fan
 and Low Profile Hood



INTAKE SYSTEMS FOR VEHICLES LISTED ARE 50 STATE LEGAL. SEE CARB STATUS ON EACH PART FOR A SPECIFIC VEHICLE.

Component Identification

1.	Airaid Premium Filter	1
2.	Rear Air Dam Coated	1
3.	MAF Panel Coated	1
4.	Air Filter Adapter	1
5.	Airaid Intake Tube	1
6.	Urethane Hump Hose	1
7.	GM Coupler	1
8.	Weather Strip 20"	1
9.	6-32x5/16" Screw	5
10.	#6 Flat Washer	5
11.	6-32 Keps Nut	5
12.	1/4-20x1/2" Button Head Bolt	3
13.	1/4" Flat Washer	7
14.	M6-1x25 Hex Bolt	4
15.	#60 Hose Clamp	2



1. **Disconnect the negative battery cable.** Loosen the hose clamps located at the Mass Air Flow (MAF) sensor, and throttle body on the factory intake tube assembly.

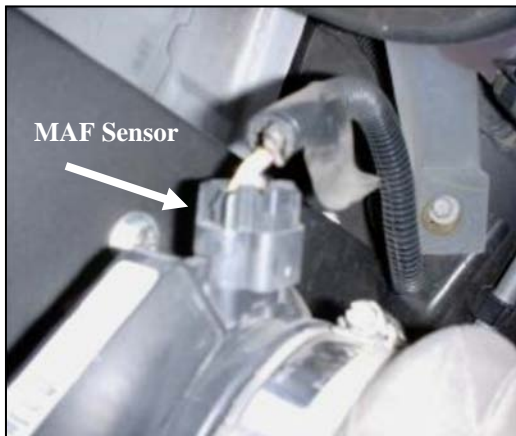

2. Disconnect the MAF sensor wiring harness and remove the sensor from the factory intake tube.



3. Using a flat head screwdriver, gently pry the radiator hose bracket from the factory intake tube assembly and remove the intake tube from the vehicle.



4. Rock the factory air box back and forth and remove it from the vehicle. There are only grommets holding it in, no bolts.



5. Using a 10mm socket, remove the five bolts that secure the factory air filter housing platform and remove it.

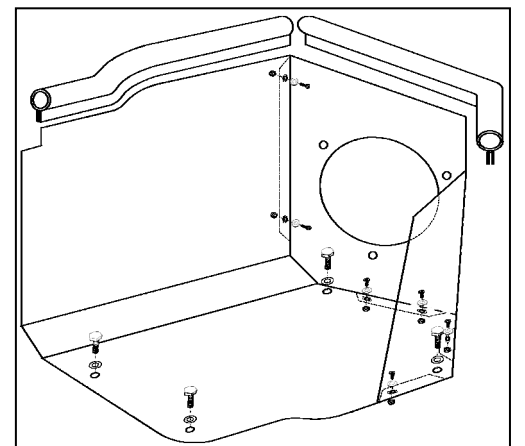

6. Assemble the Airaid Cool Air Dam panels (#2, #3) using five 6-32x 5/16" screws (#9), #6 flat washers (#10), and 6-32 keps nuts (#11).

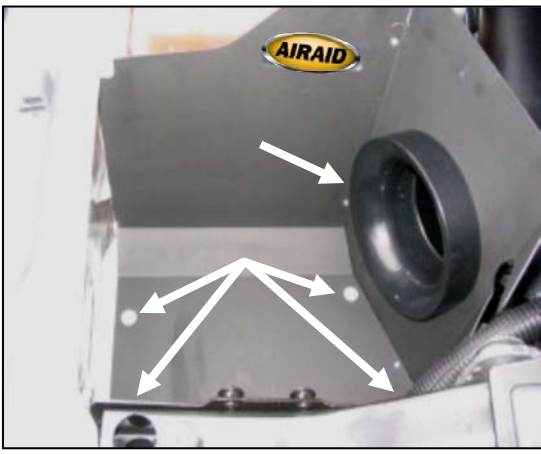

7. Install the air filter adapter (#4) using three ¼-20x ½” button head bolts (#12), and 1/4” flat washers (#13). Position the Airaid Cool Air Dam in place of the factory airbox & secure it with four M6-1x25 hex bolts (#14) and 1/4” flat washers (#13). Apply the Airaid Decal as shown.



8. Slide the factory MAF sensor onto the air filter adapter and tighten the hose clamp. (*Note: factory clamp / rubber bushing must be in place on the inlet to the MAF sensor.*)



9. Install the GM coupler (#7) onto the throttle body side of the Airaid Intake Tube (#5).

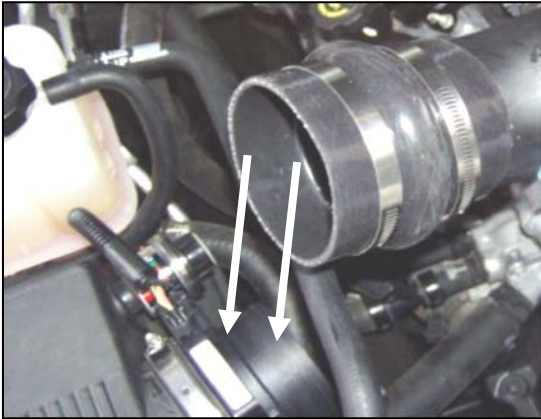

10. Install the urethane hump hose (#6) onto the Airaid Intake Tube (#5) and the MAF sensor with two #60 hose clamps (#15). Install the tube assembly onto the engine. (*Hint: slide the hump hose all the way onto the end of the tube.*)



11. Reconnect the wiring harness to the MAF sensor.

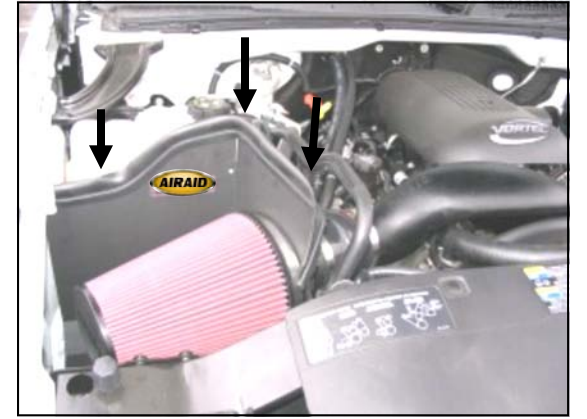

12. Press the weather strip (#8) along the top edges of the Airaid Cool Air Dam; assure that it is fully seated along the edges. (*Hint: Begin at a corner and work toward the ends*). Mount the Airaid Premium Filter (#1) onto the air filter adapter and tighten the hose clamp.

13. Double check your work!

Make sure there is no foreign material in the intake path. Make sure all clamps, hoses, bolts, and screws are tight.

14. Reconnect the negative battery cable!

Note: Provisions have been made to mount the factory filter minder if you choose. A 17mm hole must be drilled on the back side of the tube. A circular impression on the rear of the tube indicates the correct location for the hole. Use the factory grommet to mount the filter minder.

WARNING! If your vehicle has a Vehicle Emission Control Information decal affixed to the factory airbox, a new replacement label must be obtained and installed in a readily visible position in the engine compartment in order to remain CARB compliant. Failure to do so will prevent the vehicle from passing a smog check. Replacement labels can be ordered from your local dealership. Regulations state that the VECI label shall not be affixed to any equipment which is easily detached from the vehicle. Label placement, under the hood on a painted surface is recommended.

Thank you for purchasing the Airaid Intake System. Your Airaid Intake System was carefully inspected and packaged. Check that no parts are missing, or were damaged during shipping. If any parts are missing, contact Airaid. The air filter element is protected from direct exposure to water and debris; care should be taken not to drive through deep water. WATER INGESTION IS THE DRIVERS RESPONSIBILITY! The air filter is reusable and should be cleaned periodically.

FILTER IDENTIFICATION

700-469 Airaid Oiled Media
702-469 Airaid SynthaMax Dry Media - Black

701-469 Airaid SynthaMax Dry Media - Red
703-469 Airaid SynthaMax Dry Media - Blue

For your Oiled media filter we suggest using the AIRAID Filter Tune-Up Kit!



P/N 790-551 Aerosol Spray
P/N 790-550 Squeeze Spray



SynthaMax®

Do Not Oil

Synthamax Air Filters do not require oil. Service air filter as needed by cleaning with common non-petroleum all-purpose household cleaner and water. Simple Green®, Formula 409® or equivalent works great. Apply cleaner to outside of air filter and allow to soak. Then flush filter clean from the inside out with a garden hose and repeat steps if necessary. Do not apply high pressure water or air to clean filter. Allow filter to air dry and reinstall.