

Load**LIFTER** 5000™ **ULTIMATE**

ADJUSTABLE AIR HELPER SPRINGS

TOW AND HAUL WITH SAFETY AND COMFORT™



Kit Number
88275

INSTALLATION GUIDE

For maximum effectiveness and safety, please read these instructions completely before proceeding with installation.

Failure to read these instructions can result in an incorrect installation.

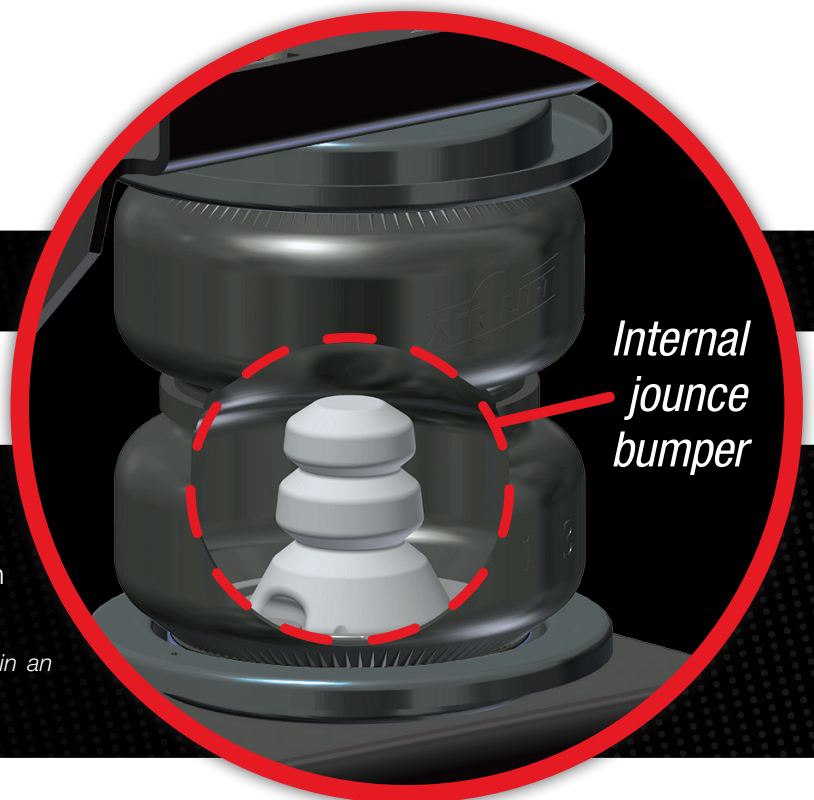

TABLE OF CONTENTS

Introduction	2
Important Safety Notice	2
Notation Explanation	2
Installation Diagram	3
Hardware List	4
Tools List	4
Installing the LoadLifter 5000 Ultimate System	4
Getting Started	4
Assembling the Air Spring Assembly	4
Removing the Jounce Bumper	6
Positioning the Assembly on the Axle	6
Attaching the Upper Bracket	7
Aligning and Attaching the Assembly and Lower Bracket	7
Installing the Emergency Brake Line Bracket and Clip	8
Installing the Heat Shield	8
Installing the Air Lines	9
Checking for Leaks	10
Fixing Leaks	10
Before Operating	11
Installation Checklist	11
Post-Installation Checklist	11
Product Use, Maintenance and Servicing	12
Minimum and Maximum Pressure	12
Maintenance Guidelines	12
Troubleshooting Guide	12
Frequently Asked Questions	13
Tuning the Air Pressure	13
Guidelines for Adding Air	14
Choosing the Right On-Board Air Compressor System	15
Limited Warranty and Return Policy	16
Replacement Information	17
Contact Information	17

Introduction

The purpose of this publication is to assist with the installation, maintenance and troubleshooting of the LoadLifter 5000 Ultimate air spring kit. LoadLifter 5000 Ultimate utilizes sturdy, reinforced, commercial grade single or double, depending on the kit, convolute bellows. The bellows are manufactured like a tire with layers of rubber and cords that control growth. An internal jounce bumper inside the spring absorbs shock and eliminates harsh jarring on rough roads. The internal jounce bumper replaces the factory bumper and allows the air springs to safely be run at zero air pressure. LoadLifter 5000 Ultimate kits are recommended for most 3/4 and 1 ton pickups and SUVs with leaf springs and provide up to 5,000 lbs. of load leveling support with air adjustability from 5-100 PSI. The kits are used in motor home rear applications and various front applications where leaf springs are used.

It is important to read and understand the entire installation guide before beginning installation or performing any maintenance, service or repair. The information here includes a hardware list, tool list, step-by-step installation information, maintenance tips, safety information and a troubleshooting guide.

IMPORTANT SAFETY NOTICE

The installation of this kit does not alter the Gross Vehicle Weight Rating (GVWR) or payload of the vehicle. Check your vehicle's owner's manual and do not exceed the maximum load listed for your vehicle.

Gross Vehicle Weight Rating: The maximum allowable weight of the fully loaded vehicle (including passengers and cargo). This number — along with other weight limits, as well as tire, rim size and inflation pressure data — is shown on the vehicle's Safety Compliance Certification Label.

Payload: The combined, maximum allowable weight of cargo and passengers that the vehicle is designed to carry. Payload is GVWR minus the Base Curb Weight.

NOTATION EXPLANATION

Hazard notations appear in various locations in this publication. Information which is highlighted by one of these notations must be observed to help minimize risk of personal injury or possible improper installation which may render the vehicle unsafe. Notes are used to help emphasize areas of procedural importance and provide helpful suggestions. The following definitions explain the use of these notations as they appear throughout this guide.

INDICATES IMMEDIATE HAZARDS WHICH WILL RESULT IN SEVERE PERSONAL INJURY OR DEATH.

 **DANGER**

INDICATES HAZARDS OR UNSAFE PRACTICES WHICH COULD RESULT IN SEVERE PERSONAL INJURY OR DEATH.

 **WARNING**

INDICATES HAZARDS OR UNSAFE PRACTICES WHICH COULD RESULT IN DAMAGE TO THE MACHINE OR MINOR PERSONAL INJURY.

 **CAUTION**

NOTE

Indicates a procedure, practice or hint which is important to highlight.

Installation Diagram

2500 HD Model, Driver Side Shown

**The 3500 model has a
different style strike plate.*

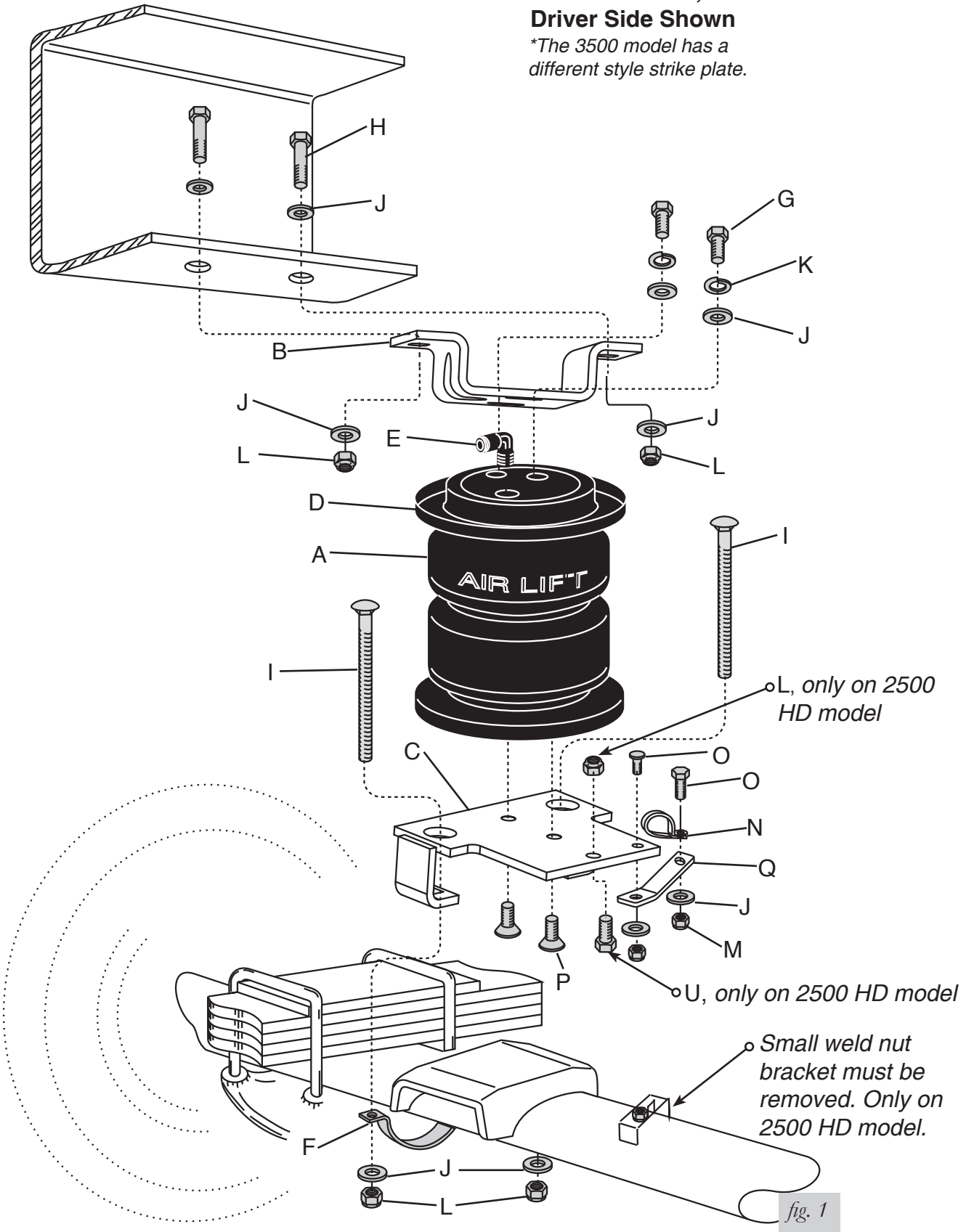

HARDWARE LIST

Item	Part #	Description.....Qty	Item	Part #	Description.....Qty
A	58496	Air spring.....2	O	17103	5/16"-18 x 1" Bolt2
B	07634	Upper bracket2	P	17215	3/8"-24 x 3/4" Flat head screw4
C	03633	Lower bracket2	Q	10421	Lower brake bracket1
D	11967	Roll plate.....4	R	10613	Heat shield1
E	21848	Elbow fitting2	S	09484	Thermal sleeve1
F	10451	Axle strap.....2	T	10741	Heat shield clamp2
G	17203	3/8"-24 x 7/8" Bolt4	U	17101	3/8"- 16 x 3/4" Bolt2
H	17108	3/8"-16 x 1.5" Bolt4	AA	20086 _{sub}	Air line assembly.....1
I	17141	3/8"-16 x 2.5" Carriage Bolt.....4	BB	10466	Tie strap6
J	18444	3/8" Flat washer23	CC	21230	Valve cap2
K	18427	3/8" Lock Washer.....4	DD	18405	5/16" Flat washer2
L	18435	3/8" Nyloc nut.....10	EE	21234	Rubber washer.....2
M	18438	5/16" Nyloc nut.....2	FF	18411	Star washer.....2
N	10465	5/8" Clip.....1	GG	21233	5/16" Hex nut4

TOOLS LIST

Description..... Qty	Description..... Qty
Hoist or floor jacks..... 1	Ratchet with 9/16", metric, & 1/2" deep well sockets 1
Safety stands..... 2	3/8" and 5/16" drill bits (very sharp)..... 2
Safety glasses 1	Heavy duty drill..... 1
Torque wrench..... 1	Hose cutter, razor blade, or sharp knife 1
5/16" open-end or box wrench..... 1	Air compressor or compressed air source..... 1
7/16" open-end or box wrench..... 1	Spray bottle with dish soap/water solution 1
9/16" open-end or box wrench..... 1	
Crescent wrench..... 1	

Installing the LoadLifter 5000 Ultimate System

GETTING STARTED

Your vehicle may be equipped with a rear brake proportioning valve. Any type of load assist product could affect brake performance. We recommend that you check with your dealer before installing this type of product. If your vehicle DOES NOT have a rear brake proportioning valve or is equipped with an anti-lock type brake system, installation of a load assist product will have NO EFFECT on brake performance.



COMPRESSED AIR CAN CAUSE INJURY AND DAMAGE TO THE VEHICLE AND PARTS IF IT IS NOT HANDLED PROPERLY. FOR YOUR SAFETY, DO NOT TRY TO INFLATE THE AIR SPRINGS UNTIL THEY HAVE BEEN PROPERLY SECURED TO THE VEHICLE.

ASSEMBLING THE AIR SPRING ASSEMBLY

1. Set a roll plate (D) on both ends of the air spring (A). The radiused (rounded) edge of the roll plate will be towards the air spring, enabling the air spring to be seated in both roll plates (Fig. 2).
2. Install a 90° elbow fitting (E) to the top of the air spring. Tighten finger tight plus 1 and 1/2 turns. Be careful to only tighten on the metal hex nut. Do not over tighten (Fig. 2).

3. Install the upper bracket (B) onto the bellow assembly. Use slot "A" when installing on the driver's side and use slot "B" when installing on the passenger's side. Attach using two 3/8" bolts (G), lock washers (K), and flat washers (J). Leave the bolts loose at this time (Figs. 2 and 3).
4. **Driver's Side Only:** Insert a 5/16" bolt (O) into the small hole on the lower bracket (C) before attaching the lower bracket to the air spring assembly (Fig. 2).
5. **2500 HD Models Only:** Install a 3/8" bolt (U) and lock nut (L) through the hole in the lower bracket (Fig. 2) with the head of the bolt facing down. Tighten securely.
6. Insert two 3/8" carriage bolts (I) through the large holes and into the square holes of the legs in the lower bracket (Fig. 2).
7. Attach the lower bracket (C) to the bottom of the bellow assembly using two 3/8" flat head screws (P). Tighten securely.

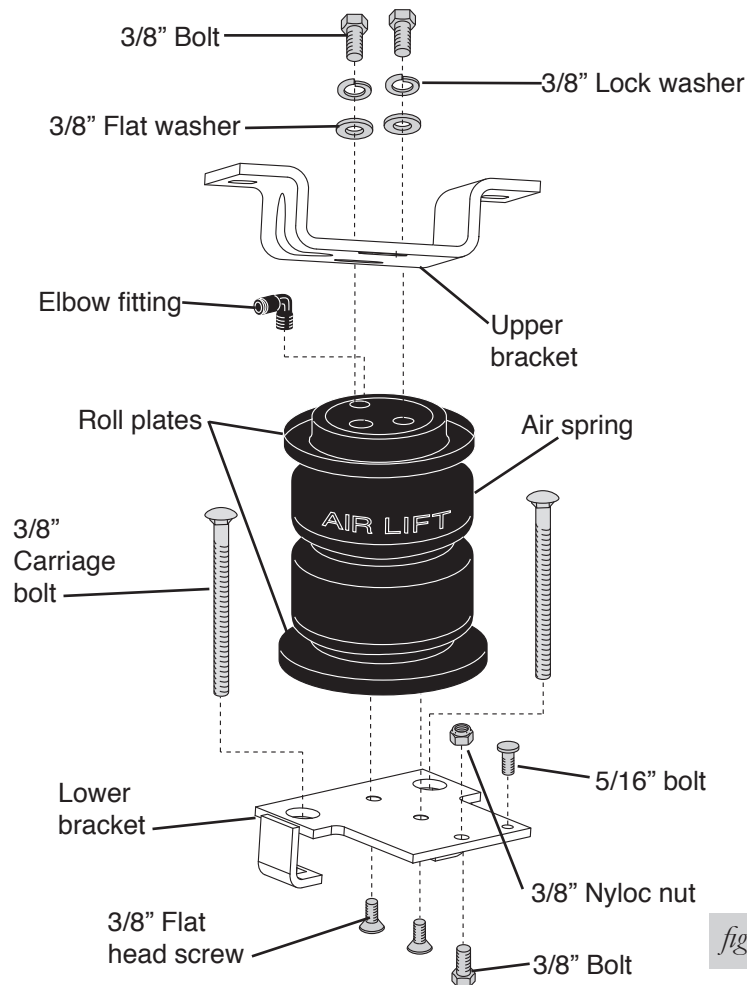

NOTE: The elbow fitting will point toward the rear of the vehicle on the driver side and toward the front of the vehicle on the passenger side.

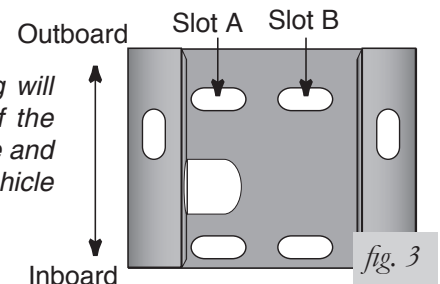

REMOVING THE JOUNCE BUMPER

1. Jack up the rear of the vehicle and support the frame with jack stands. Drop the axle to gain clearance to install the assembly.
2. Remove both jounce bumpers under the frame rail and discard.

POSITIONING THE ASSEMBLY ON THE AXLE

NOTE

On the 2500 HD models only, the driver side axle may have a small bracket with a nut that has nothing attached to it. This bracket must be trimmed off of the axle in order to install the assembly (Fig. 4).

2500 HD Models:

1. Set the assembly that has the cinch bolt onto the driver side.

NOTE

It will be necessary to index the lower legs under the jounce bumper strike plate.

2. With the lower bracket parallel to the strike plate, hook one leg under the side of the strike plate and turn the assembly until the other leg is under the strike plate on the other side (Fig. 4b).
3. Once the legs are under the strike plate, proceed with the upper bracket instructions.

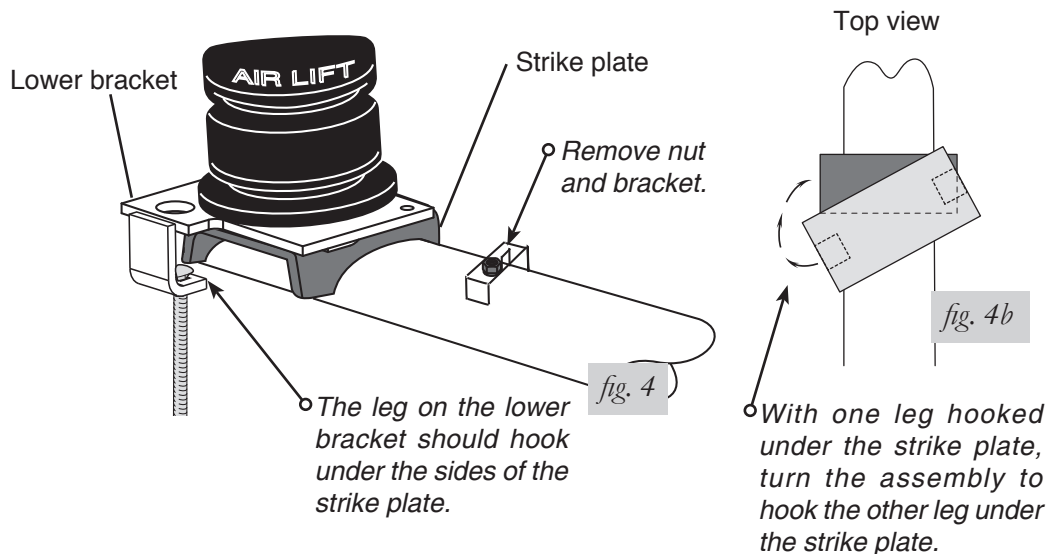

3500 Models:

1. Set the assembly on the strike plate so that the legs of the lower bracket are forward and behind the axle (Fig. 5).

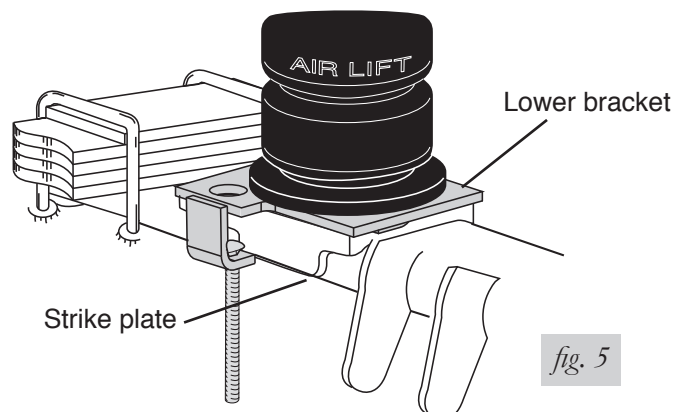

ATTACHING THE UPPER BRACKET

1. The elbow fitting points toward the rear of the vehicle on the driver side and toward the front of the vehicle on the passenger side.
2. Insert two 3/8" bolts (H) and flat washers (J) through the existing jounce bumper holes and through the slotted holes in the upper bracket (Fig. 6).

NOTE

It may be helpful to raise the axle at this point so that the upper bracket touches the frame.

3. Attach the upper bracket using two flat washers (J) and nyloc nuts (L) on each previously installed bolt (Fig. 6).
4. Push the bracket inboard and tighten both upper bolts.

NOTE

There should be a thumbs width between the bellows roll plate (D) and the leaf spring U-bolt.

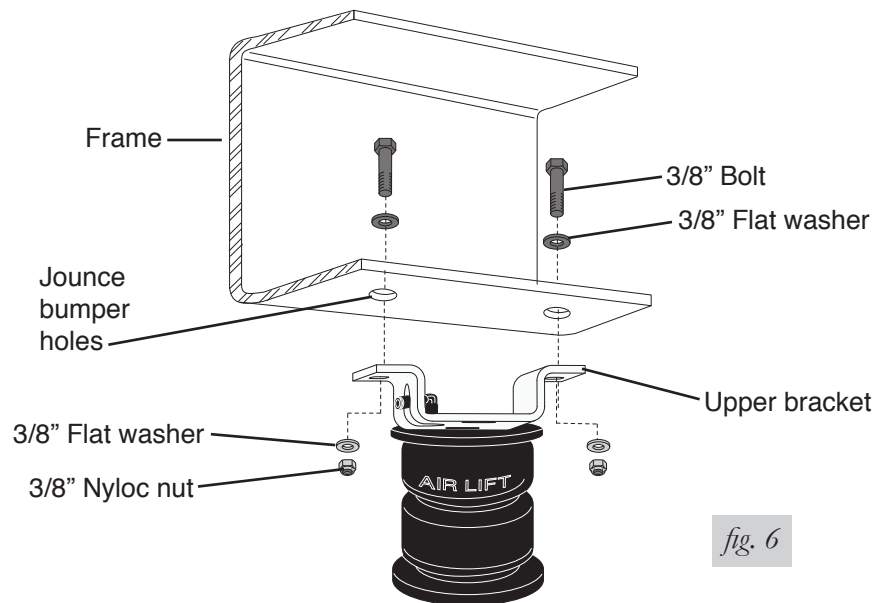

fig. 6

ALIGNING AND ATTACHING THE ASSEMBLY AND LOWER BRACKET

1. Bring the axle all the way up and remove the jack stand previously used to support the frame when removing the jounce bumper.

NOTE

The upper bracket is slotted for forward and backward adjustment. The bottom adjusts by moving the bracket on the axle in or out (Fig. 7).

2. Adjust the assembly so that the air spring is perpendicular to the bottom and top mounting brackets.
3. Tighten the top mounting bolts to 20 lb.-ft.

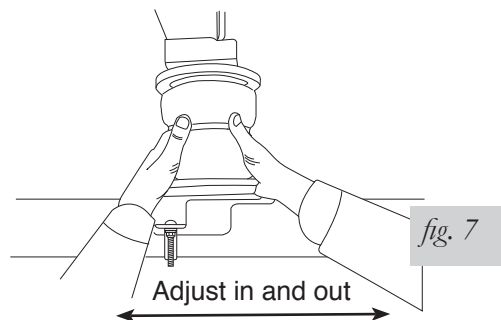

- Attach the axle strap (F) to both lower bracket carriage bolts using two flat washers (J) and two nyloc nuts (L). Torque evenly to 16 lb.-ft. (Fig. 8).

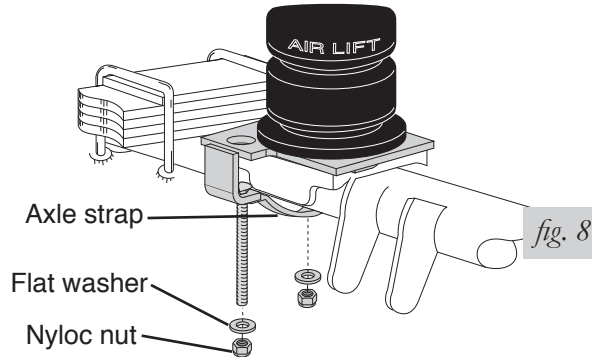

INSTALLING THE EMERGENCY BRAKE LINE BRACKET AND CLIP (DRIVER SIDE ONLY)

- Attach the brake line bracket (Q) to the lower bracket using the previously installed 5/16" bolt (O) with one flat washer (J) and a nyloc nut (M) (Fig. 9).
- Attach the brake line clip (N) onto the emergency brake line bracket (Fig. 9).
- Attach the clip assembly to the brake line bracket using a 5/16" bolt (O), two flat washers (J), and a nyloc nut (M) (Fig. 9).
- Align the brake line bracket and clip assembly so that the two do not bind to the cable. Tighten all mounting hardware in this assembly securely.

NOTE

Be sure the cable does not rub against the bellows when it is fully inflated. If it does, adjust the assembly accordingly.

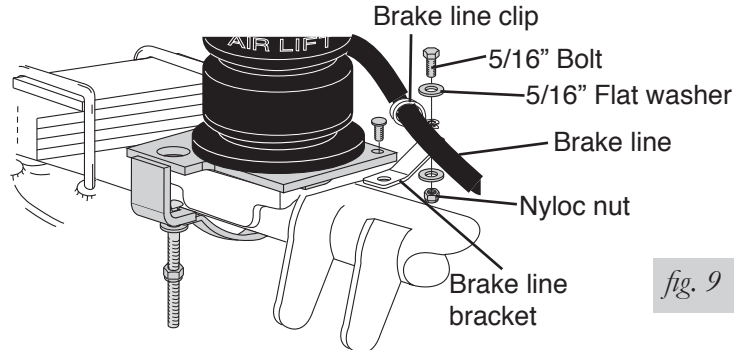

INSTALLING THE HEAT SHIELD

- Bend the tabs on the heat shield to provide a 1/2" dead air space between exhaust pipe and heat shield (Fig. 10).
- Attach the heat shield (R) to the exhaust pipe using the clamps (T) (Fig. 11). Bend the heat shield for maximum clearance to the air spring.

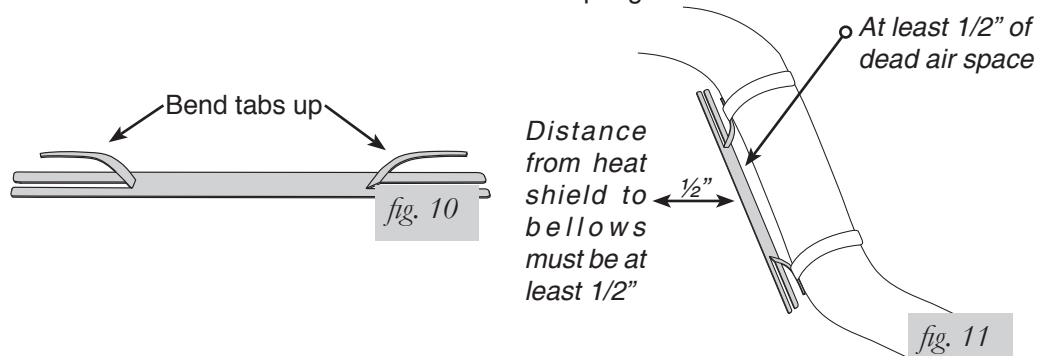

INSTALLING THE AIR LINES

1. Choose a convenient location for mounting the inflation valves. Popular locations for the inflation valve are:
 - a. The wheel well flanges.
 - b. License plate recess in bumper.
 - c. Under the gas cap access door.
 - d. Through license plate itself.

NOTE

What ever the chosen location is, make sure there is enough clearance around the inflation valves for an air chuck.

CAUTION

WHEN CUTTING OR TRIMMING THE AIR LINE, USE A HOSE CUTTER, A RAZOR BLADE OR A SHARP KNIFE. A CLEAN, SQUARE CUT WILL ENSURE AGAINST LEAKS. DO NOT USE WIRE CUTTERS OR SCISSORS TO CUT THE AIR LINE. THESE TOOLS MAY FLATTEN OR CRIMP THE AIR LINE, CAUSING IT TO LEAK AROUND THE O-RING SEAL INSIDE THE ELBOW FITTING (FIG. 12)

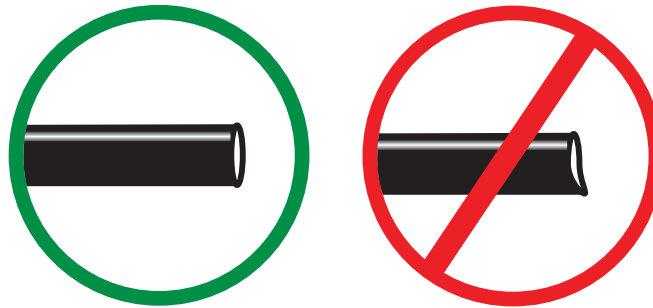

fig. 12

4. Place a 5/16" nut (GG) and a star washer (FF) on the air valve. Leave enough of the inflation valve in front of the nut to extend through the hole and have room for the rubber washer (EE), flat washer (DD), and 5/16" nut (GG) and cap (CC). There should be enough valve exposed after installation - approximately 1/2" - to easily apply a pressure gauge or an air chuck (Fig. 13).
5. Push the inflation valve through the hole and use the rubber washer (EE), flat washer (DD), and another 5/16" nut (GG). Tighten the nuts to secure the assembly in place (Fig. 13).

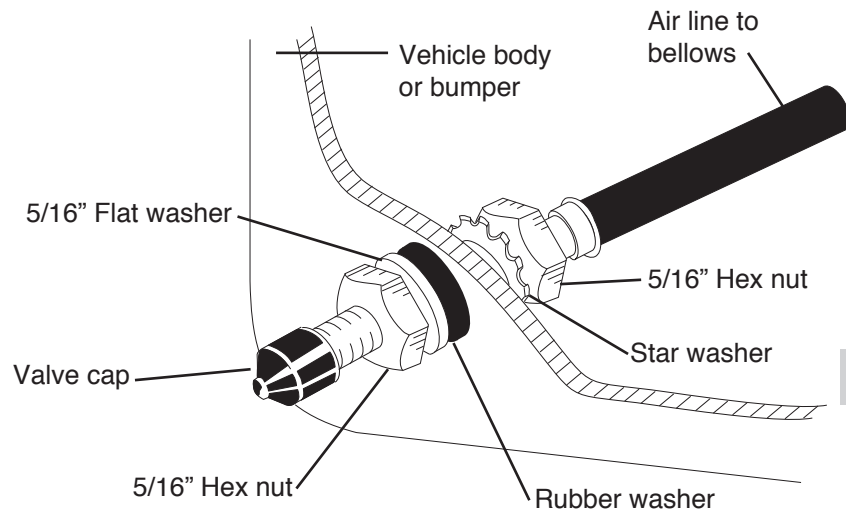
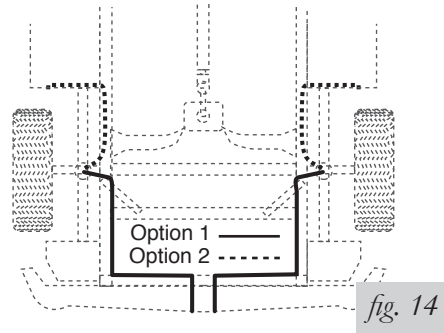

fig. 13

6. Route the air line along the frame to the air fitting on the air spring (Fig. 14). Keep AT LEAST 6" of clearance between the air line and heat sources, such as the exhaust pipes, muffler, or catalytic converter. Avoid sharp bends and edges. Use the plastic tie straps (BB) to secure the air line to fixed, non-moving points along the chassis. Be sure that the tie straps are tight, but do not pinch the air line. Leave at least 2" of slack to allow for any movement that might pull on the air line.



7. On the passenger side only, place the provided thermal sleeve (S) on the air line near the exhaust.
8. Cut off air line leaving approximately 12" of extra air line. A clean square cut will ensure against leaks (see Fig. 12). Insert the air line into the air fitting. This is a push to connect fitting. Simply push the air line into the 90° swivel fitting until it bottoms out (9/16" of air line should be in the fitting).

CHECKING FOR LEAKS

1. Inflate the air spring to 30 PSI and spray all connections and the inflation valves with a solution of 1/5 liquid dish soap and 4/5 water to check for leaks. Spot leaks easily by looking for bubbles in the soapy water.
2. After the test, deflate the springs to the minimum pressure required to restore the normal ride height, no less than 5 PSI.
3. Check the air pressure again after 24 hours. A 2-4 PSI loss after initial installation is normal. Retest for leaks if the loss is more than 5 lbs.

FIXING LEAKS

1. If there is a problem with the swivel fitting:
 - a. Check the air line connection by deflating the spring and removing the line by pulling the collar against the fitting and pulling firmly on the air line. Trim 1" off the end of the air line. Be sure the cut is clean and square (see Fig. 12). Reinsert the air line into the push-to-connect fitting.
 - b. Check the threaded connection by tightening the swivel fitting another 1/2 turn. If it still leaks, deflate the air spring, remove the fitting, and re-coat the threads with thread sealant. Reinstall by hand tightening as much as possible, then use a wrench for an additional two turns.
2. If there is a problem with the inflation valve, then:
 - a. Check the valve core by tightening it with a valve core tool.
 - b. Check the air line connection by removing the air line from the barbed type fitting.

CAUTION

DO NOT CUT THE AIR LINE COMPLETELY OFF AS THIS WILL NICK THE BARB AND RENDER THE FITTING USELESS.

Before Operating

INSTALLATION CHECKLIST (To be completed by installer)

- Clearance test — Inflate the air springs to 60 PSI and ensure there is at least 1/2” clearance around each bellow, away from anything that might rub against them. Be sure to check the tire, brake drum, frame, shock absorbers and brake cables.
- Leak test before road test — Inflate the air springs to 60 PSI, check all connections for leaks with a soapy water solution. See the *Checking for Leaks* section for tips on how to spot leaks. All leaks must be eliminated before the vehicle is road tested.
- Fastener test — Recheck all bolts for proper torque. Retorque after 100 miles.
- Road test — The vehicle should be road tested after the preceding tests. Inflate the air springs to 25 PSI (50 PSI if the vehicle is loaded). Drive the vehicle 10 miles and recheck for clearance, loose fasteners and air leaks.
- Operating instructions — If professionally installed, the installer should review the *Product Use, Maintenance and Servicing* section with the owner. Be sure to provide the owner with all of the paperwork which came with the kit.

Technician’s Signature _____

Date _____

POST-INSTALLATION CHECKLIST

- Overnight leak down test — Recheck air pressure after the vehicle has been used for 24 hours. If the pressure has dropped more than 5 PSI, then there is a leak that must be fixed. Either fix the leak yourself or return to the installer for service.
- Air pressure requirements — Regardless of load, the air pressure should always be adjusted to maintain ride height at all times.
- Thirty day or 500 mile test — Recheck the air spring system after 30 days or 500 miles, whichever comes first. If any part shows signs of rubbing or abrasion, the source should be identified and moved, if possible. If it is not possible to relocate the cause of the abrasion, the air spring may need to be remounted. If professionally installed, the installer should be consulted. Check all fasteners for tightness.

Product Use, Maintenance and Servicing

Minimum Recommended Pressure	Maximum Air Pressure
5 PSI	100 PSI

MAINTENANCE GUIDELINES

NOTE

By following the steps below, vehicle owners will obtain the longest life and best results from their air springs.

1. Check the air pressure weekly.
2. Always maintain normal ride height. Never inflate beyond 100 PSI.
3. If you develop an air leak in the system, use a soapy water solution (1/5 liquid dish soap and 4/5 water) to check all air line connections and the inflation valve core before deflating and removing the air spring.

CAUTION

FOR YOUR SAFETY AND TO PREVENT POSSIBLE DAMAGE TO YOUR VEHICLE, DO NOT EXCEED MAXIMUM GROSS VEHICLE WEIGHT RATING (GVWR), AS INDICATED BY THE VEHICLE MANUFACTURER. ALTHOUGH YOUR AIR SPRINGS ARE RATED AT A MAXIMUM INFLATION PRESSURE OF 100 P.S.I., THE AIR PRESSURE ACTUALLY NEEDED IS DEPENDANT ON YOUR LOAD AND GVWR.

4. Loaded vehicles require at least 25 PSI or more. A “loaded vehicle” refers to a vehicle with a heavy bed load, a trailer, or both. As discussed above, never exceed GVWR, regardless of air spring, air pressure, or other load assist. The springs in this kit will support approximately 40 lbs. of load (combined on both springs) for each 1 PSI of pressure. The required air pressure will vary depending on the state of the original suspension. Operating the vehicle below the minimum air spring pressure will void the Air Lift warranty.
5. When increasing load, always adjust the air pressure to maintain the normal ride height. Increase or decrease pressure from the system as necessary to attain normal ride height for optimal ride and handling. Remember that loads carried behind the axle (including tongue loads) require more leveling force (pressure) than those carried directly over the axle.
6. Always add air to springs in small quantities, checking the pressure frequently.
7. Should it become necessary to raise the vehicle by the frame, make sure the system is at minimum pressure (5 PSI) to reduce the tension on the suspension/brake components. Use of on board leveling systems do not require deflation or disconnection.
8. Periodically check the air spring system fasteners for tightness. Also, check the air springs for any signs of rubbing. Realign if necessary.
9. On occasion, give the air springs a hard spray with a garden hose in order to remove mud, sand, gravel or other abrasive debris.

TROUBLESHOOTING GUIDE

1. Leak test the air line connections, the threaded connection into the air spring, and all fittings in the control system.
2. Inspect the air lines to be sure none are pinched. Tie straps may be too tight. Loosen or replace the strap and replace leaking components.
3. Inspect the air line for holes and cracks. Replace as needed.
4. Look for a kink or fold in the air line. Reroute as needed.

FREQUENTLY ASKED QUESTIONS

Q. Will installing air springs increase the weight ratings of a vehicle?

No. Adding air springs will not change the weight ratings (GAWR, GCWR and/or GVWR) of a vehicle. Exceeding the GVWR is dangerous and voids the Air Lift warranty.

Q. Is it necessary to keep air in the air springs at all times and how much pressure will they need?

For LoadLifter 5000 Ultimate, the recommended minimum air pressure is 5 PSI, but it can safely be run at zero air pressure.

Q. Is it necessary to add a compressor system to the air springs?

No. Air pressure can be adjusted with any type of compressor as long as it can produce sufficient pressure to service the springs. Even a bicycle tire pump can be used, but it's a lot of work.

Q. How long should air springs last?

If the air springs are properly installed and maintained they can last indefinitely.

Q. Will raising the vehicle on a hoist for service work damage the air springs?

No. The vehicle can be lifted on a hoist for short-term service work such as tire rotation or oil changes. However, if the vehicle will be on the hoist for a prolonged period of time, support the axle with jack stands in order to take the tension off of the air springs.

TUNING THE AIR PRESSURE

Pressure determination comes down to three things — level vehicle, ride comfort, and stability.

1. Level vehicle

If the vehicle's headlights are shining into the trees or the vehicle is leaning to one side, then it is not level (Fig. 2.1). Raise the air pressure to correct either of these problems and level the vehicle.

2. Ride comfort

If the vehicle has a rough or harsh ride it may be due to either too much pressure or not enough (Fig. 2.2). Try different pressures to determine the best ride comfort.

3. Stability

Stability translates into safety and should be the priority, meaning the driver may need to sacrifice a perfectly level and comfortable ride. Stability issues include roll control, bounce, dive during braking and sponginess (Fig. 2.3). Tuning out these problems usually requires an increase in pressure.



Bad headlight aim *fig. 2.1*



Rough ride *fig. 2.2*

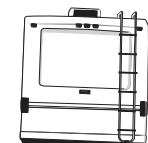

Sway and body roll *fig. 2.3*

GUIDELINES FOR ADDING AIR

1. Start with the vehicle level or slightly above.
2. When in doubt, always add air.
3. If the front of the vehicle dives while braking, increase the pressure in the front air bags, if equipped.
4. If it is ever suspected that the air bags have bottomed out, increase the pressure (Fig. 2.4).
5. Adjust the pressure up and down to find the best ride.
6. If the vehicle rocks and rolls, adjust the air pressure to reduce movement.
7. It may be necessary to maintain different pressures on each side of the vehicle. Loads such as water, fuel, and appliances will cause the vehicle to be heavier on one side (Fig. 2.5). As much as a 50 PSI difference is not uncommon.



Bottoming out

fig. 2.4

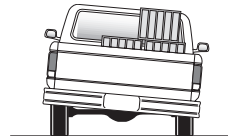

Unlevel

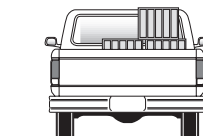

Level

fig. 2.5

Choosing the Right On-Board Air Compressor System

60 DAY NO QUESTIONS ASKED, MONEY-BACK GUARANTEE

TWO-YEAR COMPRESSOR SYSTEM WARRANTY

Add an on-board air compressor system to inflate and deflate your air springs automatically or with the touch of a button — from inside or outside of the vehicle.

- For convenient, on-the-go control of your air springs, add an Air Lift on-board air compressor system.
- Air Lift on-board air compressor systems eliminate the search for gas stations that have a working compressor, saving you time, energy and money.

- All systems include a compressor, controller and all parts needed for easy installation.

1. Choose single or dual path inflation (see illustrations at right)

2. Choose wireless, analog control or automatic

- **Wireless:** Control your air springs from inside or outside the vehicle. Easiest installation — no wires to the cab.
- **Analog:** In-cab control of your air springs. Economically priced.
- **Automatic:** Self-leveling system, keeps the vehicle level no matter what.

3. Choose heavy or standard duty compressor

- **Standard duty:** A standard duty compressor will work well for most customers who use their system on an intermittent basis.
- **Heavy duty:** For daily use, consider the heavy-duty compressor — it inflates faster and more quietly than the standard compressor.

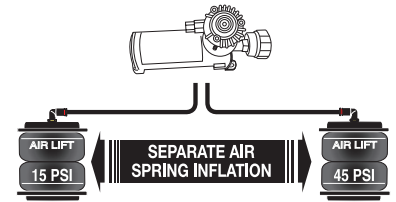

Dual path systems Air springs are controlled separately to allow for different air pressure from side-to-side. Perfect for uneven or top-heavy loads.

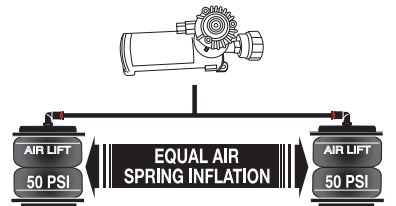

Single path systems Two springs will inflate at the same time. Good for loads that are evenly distributed from left-to-right or front-to-back.

W I R E L E S S

A N A L O G

A U T O M A T I C

WirelessAIR™

OUR PREMIUM SYSTEM!

- Easy installation
- Includes heavy-duty compressor



P/N 72000

LoadCONTROLLER™

Dual

Compact, economically priced control.



P/N Standard Duty Compressor 25850; P/N Heavy Duty Compressor 25854

WirelessONE™

- Easy installation
- Includes standard-duty compressor



P/N 25870

LoadCONTROLLER™

Single

Compact, economically priced control.



P/N Standard Duty Compressor 25852; P/N Heavy Duty Compressor 25856

SmartAIR™ II

- Easy installation
- Automatic self-leveling system
- No in-cab controls required



Single Path P/N 25490, Dual Path P/N 25491