

# Load**LIFTER**5000™

ADJUSTABLE AIR HELPER SPRINGS

TOW AND HAUL WITH SAFETY AND COMFORT™



Kit Number  
**88245**

## INSTALLATION GUIDE

For maximum effectiveness and safety, please read these instructions completely before proceeding with installation.

*Failure to read these instructions can result in an incorrect installation.*

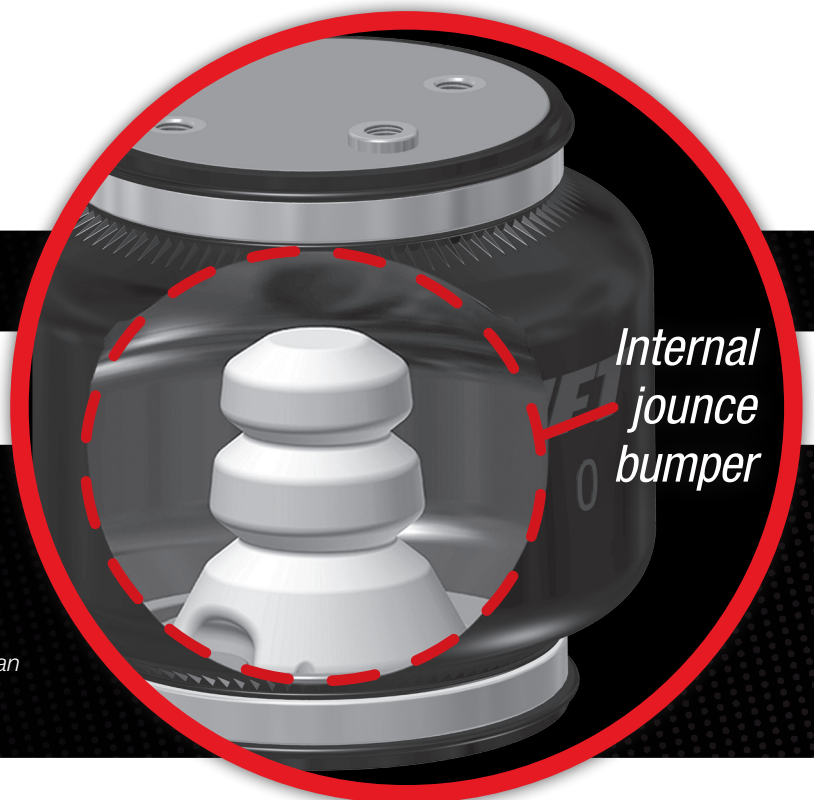

# TABLE OF CONTENTS

<b>Introduction</b> .....	<b>2</b>
Important Safety Notice .....	2
Notation Explanation .....	2
<b>Installation Diagram</b> .....	<b>3</b>
<b>Hardware and Tools Lists</b> .....	<b>4</b>
<b>Installing the LoadLifter 5000 ULTIMATE System</b> .....	<b>5</b>
Tips for Installing Air Lines .....	7
Checking for Leaks .....	9
<b>Before Operating</b> .....	<b>10</b>
Installation Checklist .....	10
Post-Installation Checklist .....	10
<b>Product Use, Maintenance and Servicing</b> .....	<b>11</b>
Minimum and Maximum Pressure .....	11
Maintenance Guidelines .....	11
Troubleshooting Guide .....	12
Frequently Asked Questions .....	12
Tuning the Air Pressure .....	13
Guidelines for Adding Air .....	13
<b>Choosing the Right On-Board Air Compressor System</b> .....	<b>14</b>
<b>Replacement Information</b> .....	<b>16</b>
<b>Contact Information</b> .....	<b>16</b>
<b>Warranty and Returns Policy</b> .....	<b>17</b>

# Introduction

The purpose of this publication is to assist with the installation, maintenance and troubleshooting of the LoadLifter 5000 ULTIMATE air spring kit. LoadLifter 5000 ULTIMATE utilizes sturdy, reinforced, commercial-grade single or double, depending on the kit, convolute bellows. The bellows are manufactured like a tire with layers of rubber and cords that control growth. An internal jounce bumper inside the spring absorbs shock and eliminates harsh jarring on rough roads. LoadLifter 5000 ULTIMATE kits are recommended for most  $\frac{3}{4}$  and 1 ton pickups and SUVs with leaf springs and provide up to 5,000 pounds of load leveling support with air adjustability from 5-100 PSI. The kits are also used in motor home rear applications and various front applications where leaf springs are used.

It is important to read and understand the entire installation guide before beginning installation or performing any maintenance, service or repair. The information here includes a hardware list, tool list, step-by-step installation information, maintenance tips, safety information and a troubleshooting guide.

## IMPORTANT SAFETY NOTICE

The installation of this kit does not alter the Gross Vehicle Weight Rating (GVWR) or payload of the vehicle. Check your vehicle's owner's manual and do not exceed the maximum load listed for your vehicle.

**Gross Vehicle Weight Rating:** The maximum allowable weight of the fully loaded vehicle (including passengers and cargo). This number — along with other weight limits, as well as tire, rim size and inflation pressure data — is shown on the vehicle's Safety Compliance Certification Label.

**Payload:** The combined, maximum allowable weight of cargo and passengers that the vehicle is designed to carry. Payload is GVWR minus the Base Curb Weight.

## NOTATION EXPLANATION

Hazard notations appear in various locations in this publication. Information which is highlighted by one of these notations must be observed to help minimize risk of personal injury or possible improper installation which may render the vehicle unsafe. Notes are used to help emphasize areas of procedural importance and provide helpful suggestions. The following definitions explain the use of these notations as they appear throughout this guide.

INDICATES IMMEDIATE HAZARDS WHICH WILL RESULT IN SEVERE PERSONAL INJURY OR DEATH.

INDICATES HAZARDS OR UNSAFE PRACTICES WHICH COULD RESULT IN SEVERE PERSONAL INJURY OR DEATH.

INDICATES HAZARDS OR UNSAFE PRACTICES WHICH COULD RESULT IN DAMAGE TO THE MACHINE OR MINOR PERSONAL INJURY.



---

## NOTE

*Indicates a procedure, practice or hint which is important to highlight.*

---

# Installation Diagram

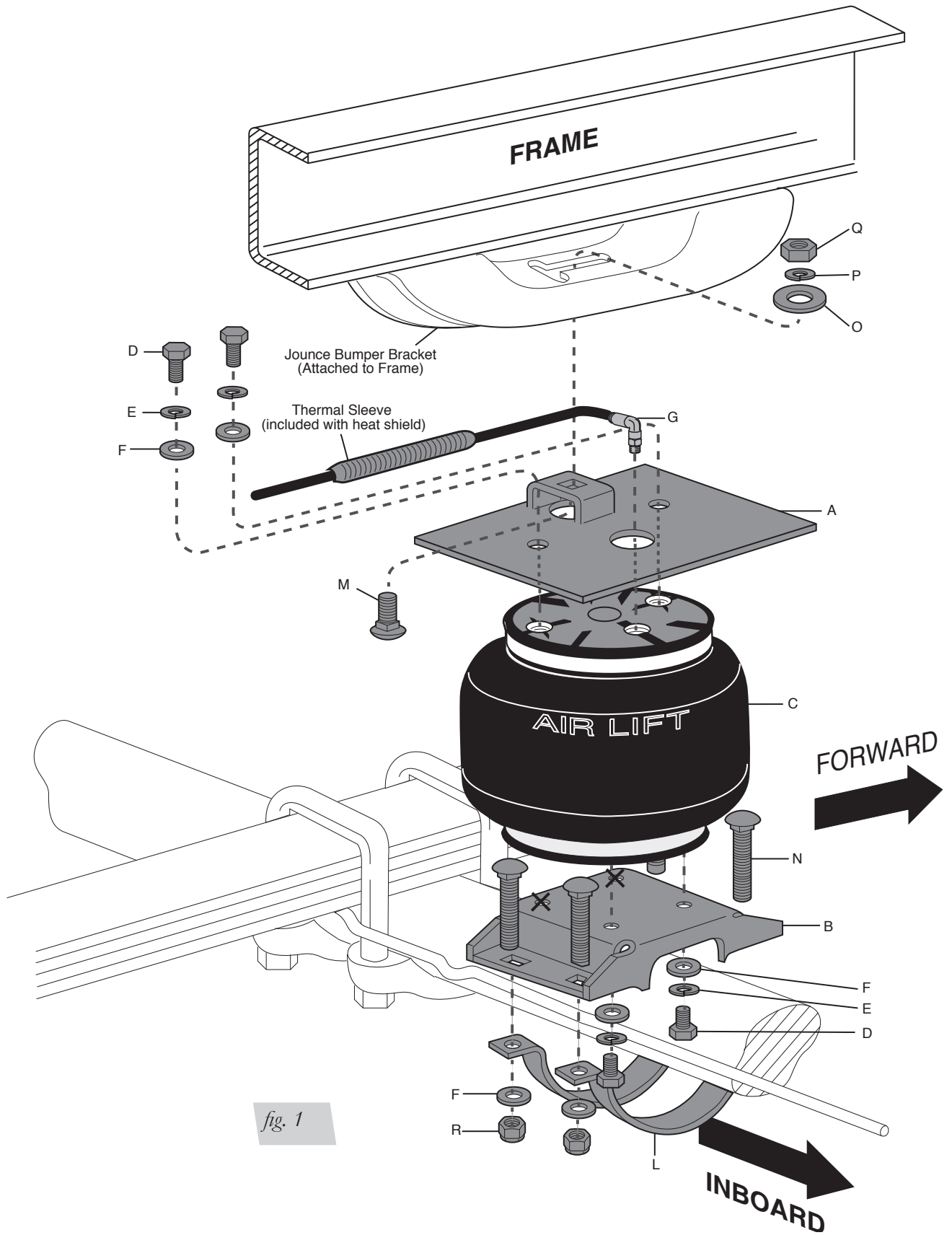

# Hardware and Tools Lists

## HARDWARE LIST

Item	Part #	Description.....	Qty
A	07847	Upper Bracket .....	2
B	03020	Lower Bracket .....	2
C	58740	Bellows .....	2
D	17203	3/8"-24X7/8" Hex Cap Screw .....	8
E	18427	3/8" Split Lock Washer .....	8
F	18444	3/8" Flat Washer .....	16
G	21837	90° Swivel Fitting.....	2
H	13232	Spacer .....	1
I	17252	M8-1.25X35 Bolt.....	1
J	18501	M8 Flat Washer .....	2
K	20086	Hose Assembly .....	1
L	01815	Axle Strap .....	4
M	17186	1/2"-13X1-1/2" Carriage Bolt .....	2
N	17277	3/8"-16X3" Carriage Bolt .....	8
O	18414	1/2" Flat Washer .....	2
P	18429	1/2" Split Lock Washer .....	2
Q	18431	1/2"-13 Nut .....	2
R	18435	3/8"-16 Nylon Lock Nut.....	8
S	10466	Zip Tie .....	6
T	18411	5/16" Serrated Lock Washer .....	2
U	21230	Valve Cap.....	2
V	21233	5/16" Hex Nut .....	4
W	21234	5/16" Flat Washer .....	2

## TOOLS LIST

### Description

Standard open end or box end wrenches  
Ratchet with standard sockets  
Drill and 5/16", 1/2" Drill Bits  
Torque Wrench  
Hose Cutter, Razor Blade or Sharp Knife  
Safety Glasses  
Air Compressor or Compressed Air Source  
Spray Bottle with Dish Soap/Water Solution

# Installing the LoadLifter5000 ULTIMATE System

## WARNING

DO NOT INFLATE THE BELLOWS WHEN THEY ARE UNRESTRICTED OR NOT INSTALLED. BELLOWS MUST BE CONTAINED BY SUSPENSION OR OTHER ADEQUATE STRUCTURE. DO NOT INFLATE BEYOND 100 PSI IMPROPER USE OR OVER-INFLATION MAY CAUSE THE ASSEMBLY TO BURST CAUSING PROPERTY DAMAGE OR SEVERE PERSONAL INJURY.

**NORMAL RIDE HEIGHT** (no load): — This is defined as the distance between the bottom edge of the fenderwell to the center point of the wheel with the vehicle in an “as-delivered condition” (without a load, i.e. tool box, camper, etc.) measurements should be taken before beginning the installation. The distance from the bottom edge of the fender well to the center point of the wheel should be recorded. All Air Lift kits are designed to be installed and operated at normal ride height.

Measure and record the normal ride height for later reference.

1. Jack up rear of vehicle or raise on hoist. Place safety jack stands under axle.
2. Install the fitting finger-tight plus 1 1/2 turns being careful to tighten on the metal hex nut only.
3. Insert a 1 1/2” carriage bolt (M) into the square hole of the upper bracket. Attach the upper bracket to the top plate of the air spring with two bolts (D), flat washers (F) and lock washers (E). (Fig. 1)
4. Attach the lower bracket to the bottom plate of the air spring using the mounting holes shown in Fig. 2. The lower bracket will be offset outboard away from the air fitting (Fig. 4). Attach with 7/8” two bolts (D), flat washers (F) and lock washers (E). Torque to 20 lb./ft. Assemble units for both sides.

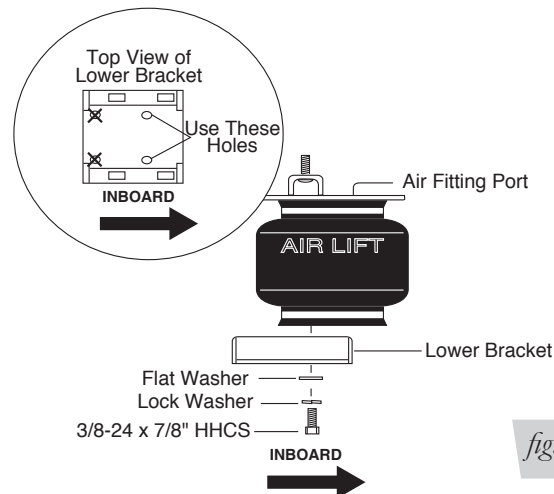

5. Remove the rubber jounce bumper on the frame rail by pulling it out of the slotted track in the jounce bumper bracket.
6. Set the assembly on the axle housing (Fig. 1). Push the threaded portion of the carriage bolt into the jounce bumper track. Loosely attach the upper bracket to the frame with a 1 1/2” carriage bolt (M), flat washer (O), lock washer (P), and nut (Q). (Fig. 1)

- On models with disc brakes, make sure that the emergency brake cable is above the upper bracket on the driver's side. Also, remove the bolt holding the cable onto the back-side of the passenger's side axle. Install the supplied spacer between the bracket and the emergency brake cable clip. Insert the supplied bolt and tighten the cable down securely. (Fig. 3)

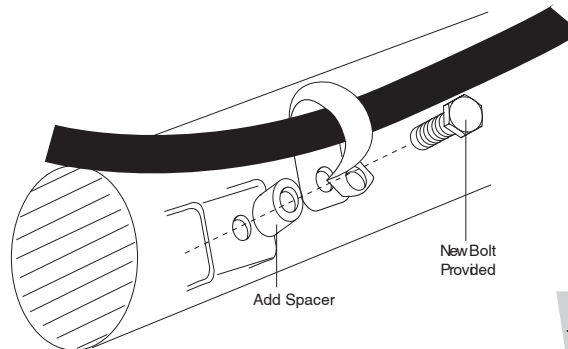

- LOOSELY attach the lower bracket and straps around the axle using the 3" carriage bolts (N), flat washers (F) and lock nuts (R). Both straps will be attached between the leaf spring stack and the shock mount bracket. (Fig. 4)

## NOTE

*For models with disc brakes: The inside strap on the passenger-side goes between the emergency brake cable bracket and the shock bracket on the axle. (Fig. 4)*

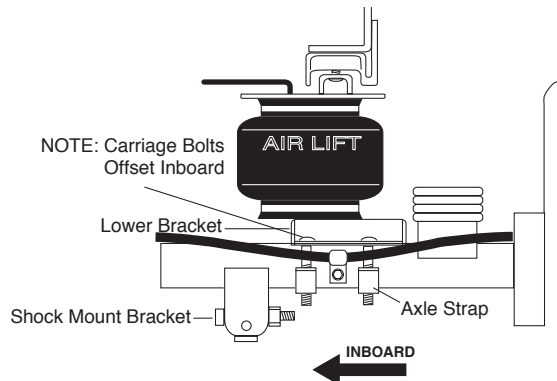

- Align the air spring. With the unit aligned, tighten the lower bracket securely to the axle.

## NOTE

*The air spring should have at least a "thumbs width" clearance between it and any interference.*

- Tighten the FRONT 3/8" nylon lock nuts first and then the rear nuts to prevent any interference with the brake line. Torque to 20 lb./ft.

- Torque the 1/2" nut on the upper bracket to 20 lb./ft. (Fig. 1)

12. Installation of this kit requires an exhaust heat shield (Fig. 5). The shield is attached with the stainless steel clamps to the exhaust pipe, with the flanges bent inward. Shield may be trimmed or bent to attain component clearance. Bend tabs to provide 1/2" dead air space between exhaust pipes and heat shield and maximum clearance with air springs.

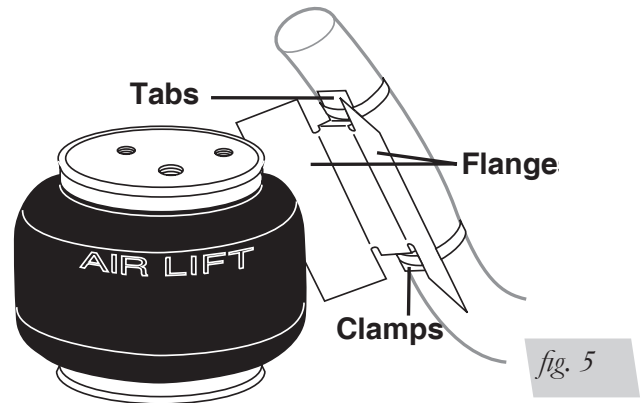

13. Select a location for the inflation valves in the rear bumper area or rocker panel flange ensuring that each valve will be protected and accessible with an air hose. (Fig. 6)

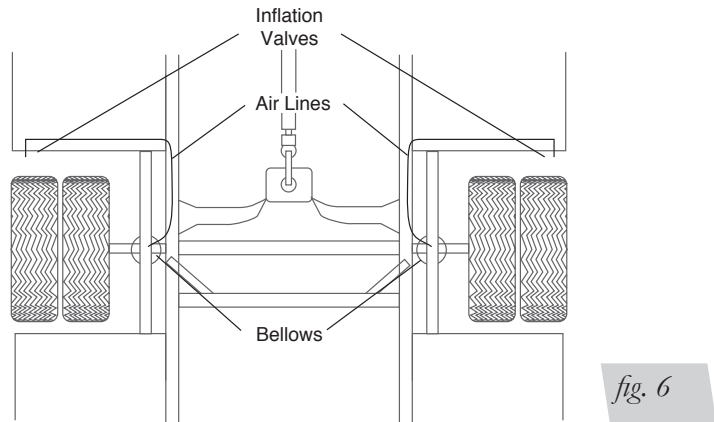

**TIPS FOR INSTALLING AIR LINES**

When cutting air lines, use a sharp knife or a hose cutter and make clean, square cuts (Fig. 7). Do not use scissors or wire cutters because these tools may deform the air line, causing it to leak around fittings. Do not cut the lines at an angle.

Do not bend the 1/4" hose at a radius of less than 1" and don't put side load pressure on fitting. The hose should be straight beyond the fitting for 1" before bending.

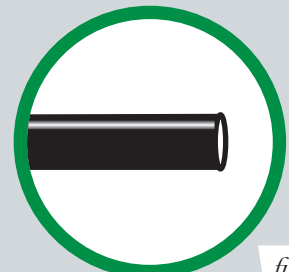
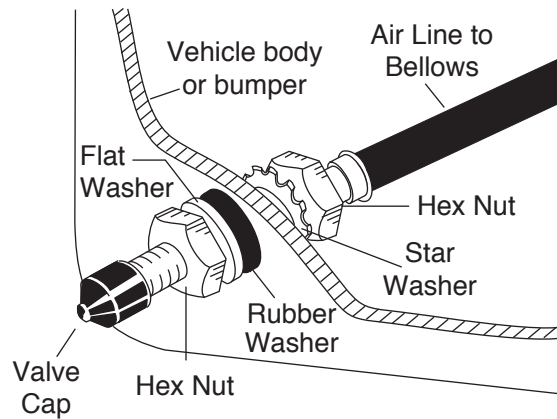

fig. 7



14. Cut the air line assembly into the equal parts. Drill 5/16" hole for inflation valves and mount as illustrated. Rubber washer on the outside is for weather seal. (Fig. 8)

*fig. 8*
**CAUTION**

LEAVE SUFFICIENT HOSE SLACK TO PREVENT ANY STRAIN ON VALVE STEM DURING NORMAL AXLE MOTIONS.

15. Route the air line from the inflation valve location along the frame rail to the air springs. Route the air line so that it will be protected from the direct heat from the muffler or tailpipe and kept away from sharp edges. The air line should not be bent or curved sharply (Fig. 6). Attach air line to chassis with the provided plastic straps.

**NOTE**

*To prevent the air line from melting, keep it at least six inches from the exhaust system. Use the thermal sleeve on the exhaust side. (Fig. 1)*

16. Slide a thermal sleeve onto the air line from the cut end on the tail pipe side of the vehicle.
17. Cut off the excess air line squarely and install into the fitting. This is a push-to-connect fitting. Push and slightly turn the cut end of the air line into the fitting as far as it will go (5/16"). You will hear/feel a definite "click" when the air line is seated. The air line is now installed.
18. Repeat process for the other side.
19. Inflate the air springs to 60 PSI air pressure. Test for air leaks by applying a soapy solution to all valve cores, fittings and connections.
20. The installation is complete. Before proceeding, check once again to be sure there is a sufficient clearance around the air springs.
21. Lower the vehicle. Inflate the air springs until normal ride height measurement is restored. Air pressure should be adjusted so that the normal ride height is maintained at all times.
22. A 5-7 PSI loss after initial installation is normal. If pressure has dropped more than 7 PSI, re-test for leaks with soapy water solution.
23. For best ride, use only enough air pressure in the air springs to maintain normal ride height.

**NOTE**

*Too much air pressure in the air springs will result in a stiffer ride, while too little air pressure will allow the vehicle to bottom out. Too little air pressure will also not provide the improvement in ride and handling that is possible.*

## CHECKING FOR LEAKS

1. Inflate the bellows and check the fittings for air leaks with a solution of soap and water.
2. Raise vehicle and remove safety jack stands. Lower vehicle to ground.
3. This now completes the installation. Before proceeding, check once again to be sure there is proper clearance around the bellows. With a load on the vehicle and the helper springs inflated, there must be at least 1/2" clearance all around the bellows.
4. Recheck air pressure after 24 hours. A 5-7 PSI loss after initial installation is normal. If pressure has dropped more than 7 PSI, retest for leaks with a soapy water solution.
5. For best ride use only enough air pressure in the air springs to level the vehicle when viewed from the side (front to rear). Inflate/deflate the air springs to maintain this height under various conditions of load.

# Before Operating

## INSTALLATION CHECKLIST (To be completed by installer)

- Clearance test — Inflate the air springs to 60 PSI and ensure there is at least 1/2" clearance around each bellow, away from anything that might rub against them. Be sure to check the tire, brake drum, frame, shock absorbers and brake cables.
- Leak test before road test — Inflate the air springs to 60 PSI, check all connections for leaks with a soapy water solution. See page 12 for tips on how to spot leaks. All leaks must be eliminated before the vehicle is road tested.
- Fastener test — Recheck all bolts for proper torque. Axle clamp bar carriage bolt lock nuts should be torqued to 16 lb.-ft. Re-torque after 100 miles.
- Road test — The vehicle should be road tested after the preceding tests. Inflate the air springs to 25 PSI (50 PSI if the vehicle is loaded). Drive the vehicle 10 miles and recheck for clearance, loose fasteners and air leaks.
- Operating instructions — If professionally installed, the installer should review the Product Use, Maintenance and Servicing section on page 14 with the owner. Be sure to provide the owner with all of the paperwork which came with the kit.

**Technician's Signature** \_\_\_\_\_

**Date** \_\_\_\_\_

## POST-INSTALLATION CHECKLIST

- Overnight leak down test — Recheck air pressure after the vehicle has been used for 24 hours. If the pressure has dropped more than 5 PSI, then there is a leak that must be fixed. Either fix the leak yourself or return to the installer for service.
- Air pressure requirements — Regardless of load, the air pressure should always be adjusted to maintain ride height at all times.
- Thirty-day or 500-mile test — Recheck the air spring system after 30 days or 500 miles, whichever comes first. If any part shows signs of rubbing or abrasion, the source should be identified and moved, if possible. If it is not possible to relocate the cause of the abrasion, the air spring may need to be remounted. If professionally installed, the installer should be consulted. Check all fasteners for tightness.

# Product Use, Maintenance and Servicing

Minimum Recommended Pressure	Maximum Air Pressure
5 PSI	100 PSI

## MAINTENANCE GUIDELINES

### NOTE

*By following the steps below, vehicle owners will obtain the longest life and best results from their air springs.*

### CAUTION

FOR YOUR SAFETY AND TO PREVENT POSSIBLE DAMAGE TO YOUR VEHICLE, DO NOT EXCEED MAXIMUM GROSS VEHICLE WEIGHT RATING (GVWR), AS INDICATED BY THE VEHICLE MANUFACTURER. ALTHOUGH YOUR AIR SPRINGS ARE RATED AT A MAXIMUM INFLATION PRESSURE OF 100 PSI, THE AIR PRESSURE ACTUALLY NEEDED IS DEPENDANT ON LOAD AND GVWR.

1. Check the air pressure weekly.
2. Always maintain normal ride height. Never inflate beyond 100 PSI.
3. If you develop an air leak in the system, use a soapy water solution (1/5 liquid dish soap and 4/5 water) to check all air line connections and the inflation valve core before deflating and removing the air spring.
4. Loaded vehicles require at least 25 PSI or more. A “loaded vehicle” refers to a vehicle with a heavy bed load, a trailer or both. As discussed above, never exceed GVWR, regardless of air spring, air pressure, or other load assist. The springs in this kit will support approximately 40 pounds of load (combined on both springs) for each 1 PSI of pressure. The required air pressure will vary depending on the state of the original suspension. Operating the vehicle below the minimum air spring pressure will void the Air Lift warranty.
5. When increasing load, always adjust the air pressure to maintain the normal ride height. Increase or decrease pressure from the system as necessary to attain normal ride height for optimal ride and handling. Remember that loads carried behind the axle (including tongue loads) require more leveling force (pressure) than those carried directly over the axle.
6. Always add air to springs in small quantities, checking the pressure frequently.
7. Should it become necessary to raise the vehicle by the frame, make sure the system is at minimum pressure (5 PSI) to reduce the tension on the suspension/ brake components. Use of on board leveling systems do not require deflation or disconnection.
8. Periodically check the air spring system fasteners for tightness. Also, check the air springs for any signs of rubbing. Realign if necessary.
9. On occasion, give the air springs a hard spray with a garden hose in order to remove mud, sand, gravel or other abrasive debris.

## **TROUBLESHOOTING GUIDE**

1. Leak test the air line connections, the threaded connection into the air spring, and all fittings in the control system.
2. Inspect the air lines to be sure none are pinched. Tie straps may be too tight. Loosen or replace the strap and replace leaking components.
3. Inspect the air line for holes and cracks. Replace as needed.
4. Look for a kink or fold in the air line. Reroute as needed.

## **FREQUENTLY ASKED QUESTIONS**

### **Q. Will installing air springs increase the weight ratings of a vehicle?**

No. Adding air springs will not change the weight ratings (GAWR, GCWR and/ or GVWR) of a vehicle. Exceeding the GVWR is dangerous and voids the Air Lift warranty.

### **Q. Is it necessary to keep air in the air springs at all times and how much pressure will they need?**

For LoadLifter 5000 Ultimate, the recommended minimum air pressure is 5 PSI, but it can safely be run at zero air pressure.

### **Q. Is it necessary to add a compressor system to the air springs?**

No. Air pressure can be adjusted with any type of compressor as long as it can produce sufficient pressure to service the springs. Even a bicycle tire pump can be used, but it's a lot of work.

### **Q. How long should air springs last?**

If the air springs are properly installed and maintained they can last indefinitely.

### **Q. Will raising the vehicle on a hoist for service work damage the air springs?**

No. The vehicle can be lifted on a hoist for short-term service work such as tire rotation or oil changes. However, if the vehicle will be on the hoist for a prolonged period of time, support the axle with jack stands in order to take the tension off of the air springs.

## TUNING THE AIR PRESSURE

Pressure determination comes down to three things — level vehicle, ride comfort, and stability.

### 1. Level vehicle

If the vehicle's headlights are shining into the trees or the vehicle is leaning to one side, then it is not level (fig. a). Raise the air pressure to correct either of these problems and level the vehicle.

### 2. Ride comfort

If the vehicle has a rough or harsh ride it may be due to either too much pressure or not enough (fig. b). Try different pressures to determine the best ride comfort.

### 3. Stability

Stability translates into safety and should be the priority, meaning the driver may need to sacrifice a perfectly level and comfortable ride. Stability issues include roll control, bounce, dive during braking and sponginess (fig. c). Tuning out these problems usually requires an increase in pressure.

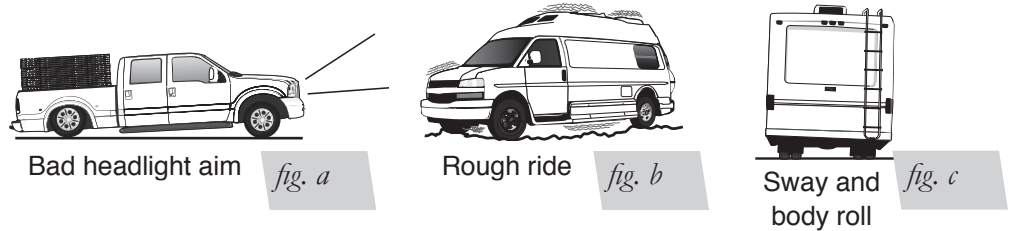

## GUIDELINES FOR ADDING AIR

1. Start with the vehicle level or slightly above.
2. When in doubt, always add air.
3. If the front of the vehicle dives while braking, increase the pressure in the front air bags, if equipped.
4. If it is ever suspected that the air bags have bottomed out, increase the pressure (fig. d).
5. Adjust the pressure up and down to find the best ride.
6. If the vehicle rocks and rolls, adjust the air pressure to reduce movement.
7. It may be necessary to maintain different pressures on each side of the vehicle. Loads such as water, fuel, and appliances will cause the vehicle to be heavier on one side (fig. e). As much as a 50 PSI difference is not uncommon.

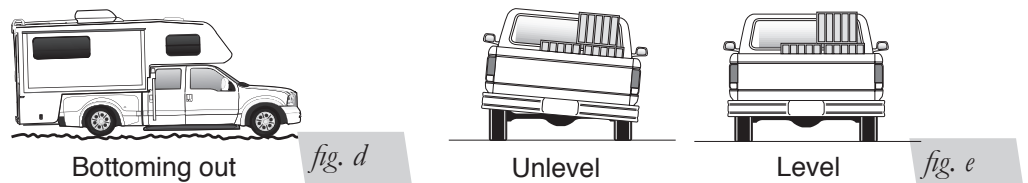

# Choosing the Right On-Board Air Compressor System

**60 DAY** NO QUESTIONS ASKED, MONEY-BACK GUARANTEE

**TWO-YEAR** COMPRESSOR SYSTEM WARRANTY

Add an on-board air compressor system to inflate and deflate your air springs automatically or with the touch of a button — from inside or outside of the vehicle.

- For convenient, on-the-go control of your air springs, add an Air Lift on-board air compressor system.
- Air Lift on-board air compressor systems eliminate the search for gas stations that have a working compressor, saving you time, energy and money.
- All systems include a compressor, controller and all parts needed for easy installation.

**1. Choose single or dual path inflation (see illustrations at right)**

**2. Choose wireless, analog control or automatic**

- **Wireless:** Control your air springs from inside or outside the vehicle. Easiest installation — no wires to the cab.
- **Analog:** In-cab control of your air springs. Economically priced.
- **Automatic:** Self-leveling system, keeps the vehicle level no matter what.

**3. Choose heavy or standard duty compressor**

- **Standard duty:** A standard duty compressor will work well for most customers who use their system on an intermittent basis.
- **Heavy duty:** For daily use, consider the heavy-duty compressor — it inflates faster and more quietly than the standard compressor.

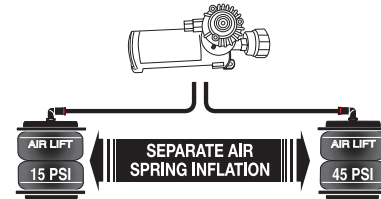

*Dual path systems* Air springs are controlled separately to allow for different air pressure from side-to-side. Perfect for uneven or top-heavy loads.

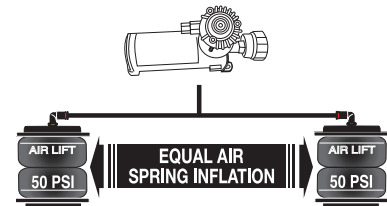

*Single path systems* Two springs will inflate at the same time. Good for loads that are evenly distributed from left-to-right or front-to-back.

W I R E L E S S

A N A L O G

A U T O M A T I C

**WirelessAIR™**

**OUR PREMIUM SYSTEM!**

- Easy installation
- Includes heavy-duty compressor



P/N 72000

**LoadCONTROLLER™**

**Dual**

Compact, economically priced control.

P/N Standard Duty Compressor 25850; P/N Heavy Duty Compressor 25854



**WirelessONE™**

- Easy installation
- Includes standard-duty compressor



**LoadCONTROLLER™**

**Single**

Compact, economically priced control.



**SmartAIR™ II**

- Easy installation
- Automatic self-leveling system
- No in-cab controls required

