

**Air Lift**<sup>™</sup>  
**PERFORMANCE**

**Kit 78603**  
Volkswagen MKI  
**Rear Application**



## **INSTALLATION GUIDE**

For maximum effectiveness and safety, please read these instructions completely before proceeding with installation.

*Failure to read these instructions can result in an incorrect installation.*

PERFORMANCE SUSPENSION PARTS



# Introduction

The purpose of this publication is to assist with the installation, maintenance and troubleshooting of this Volkswagen MKI Performance kit.

It is important to read and understand the entire installation guide before beginning installation or performing any maintenance, service or repair. The information includes a hardware list, step-by-step installation information, maintenance tips, safety information and a troubleshooting guide.

## NOTATION EXPLANATION

Hazard notations appear in various locations in this publication. Information which is highlighted by one of these notations must be observed to help minimize risk of personal injury or possible improper installation which may render the vehicle unsafe. Notes are used to help emphasize areas of procedural importance and provide helpful suggestions. The following definitions explain the use of these notations as they appear throughout this guide.

-  **DANGER** INDICATES IMMEDIATE HAZARDS WHICH WILL RESULT IN SEVERE PERSONAL INJURY OR DEATH.
-  **WARNING** INDICATES HAZARDS OR UNSAFE PRACTICES WHICH COULD RESULT IN SEVERE PERSONAL INJURY OR DEATH.
-  **CAUTION** INDICATES HAZARDS OR UNSAFE PRACTICES WHICH COULD RESULT IN DAMAGE TO THE MACHINE OR MINOR PERSONAL INJURY.

---

**NOTE** *Indicates a procedure, practice or hint which is important to highlight.*



---

## IMPORTANT SAFETY NOTICES

The installation of this kit does not alter the Gross Vehicle Weight Rating (GVWR) or payload of the vehicle. Check your vehicle's owner's manual and do not exceed the maximum load listed for your vehicle.

**Gross Vehicle Weight Rating:** The maximum allowable weight of the fully loaded vehicle (including passengers and cargo). This number — along with other weight limits, as well as tire, rim size and inflation pressure data — is shown on the vehicle's Safety Compliance Certification Label.

**Payload:** The combined, maximum allowable weight of cargo and passengers that the vehicle is designed to carry. Payload is GVWR minus the Base Curb Weight.

-  **WARNING** DO NOT INFLATE AIR SPRINGS WHILE OFF OF THE VEHICLE. DAMAGE TO ASSEMBLY MAY RESULT AND VOID WARRANTY.
-  **CAUTION** DO NOT WELD TO, OR MODIFY PERFORMANCE STRUTS/SHOCKS IN ANY WAY. DAMAGE TO UNIT MAY OCCUR AND WILL VOID WARRANTY.

# Installation Diagram

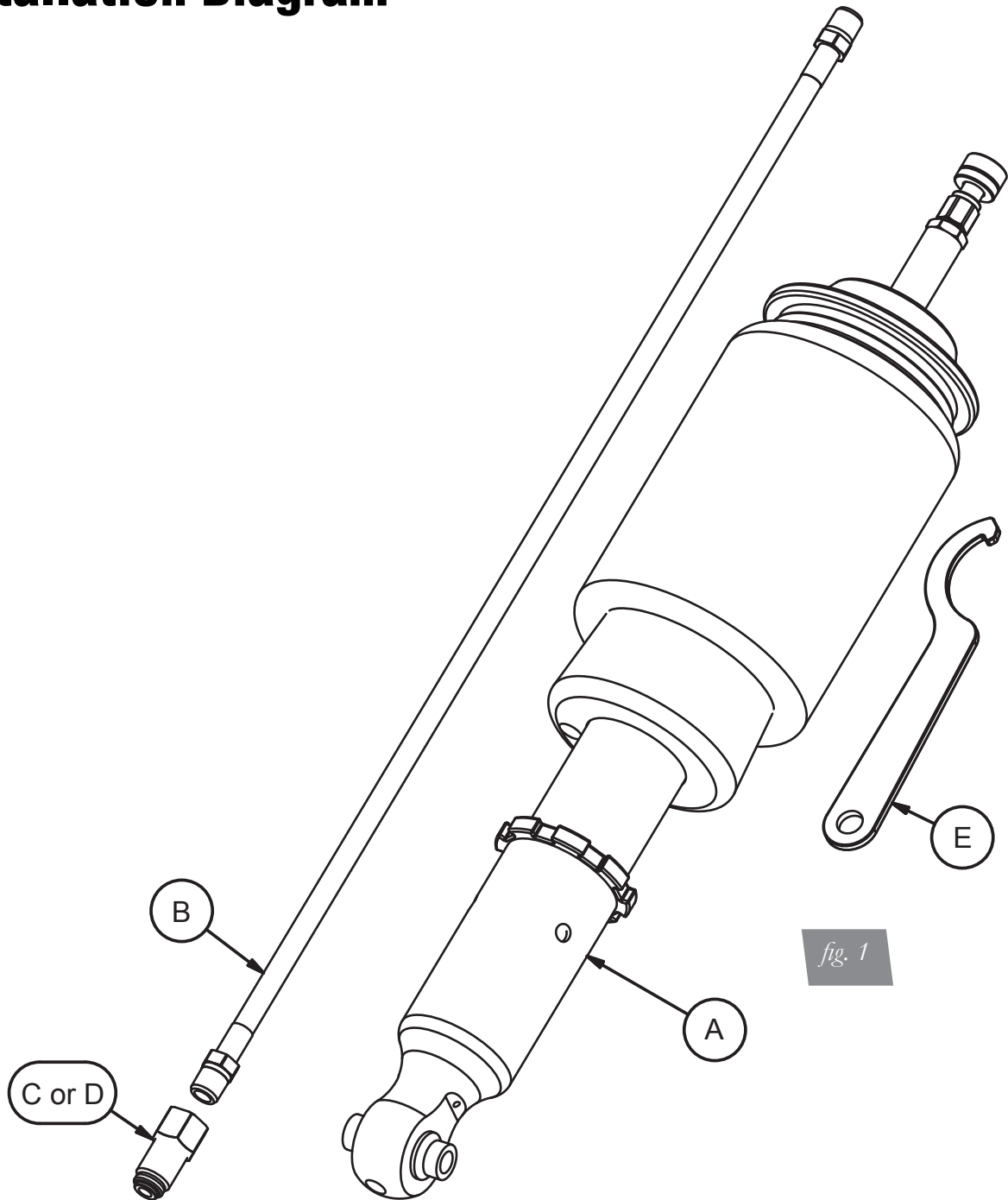

## HARDWARE LIST

Item	Part #	Description .....	Qty
A	35291	Shock, Volkswagen MKI Rear .....	2
B	20997	Leader Hose, 1/4" ID .....	2
C	21987	Union, 1/4"FNPT X 3/8" PTC, DOT .....	2
D	21810	Union, 1/4"FNPT X 1/4" PTC, DOT .....	2
E		Spanner Wrench.....	1

# Installing the Air Suspension

## PREPARING THE VEHICLE

1. Elevate and support the vehicle with a hoist or jack stands.
2. Remove the rear wheel and support the hub assembly (fig. 2).

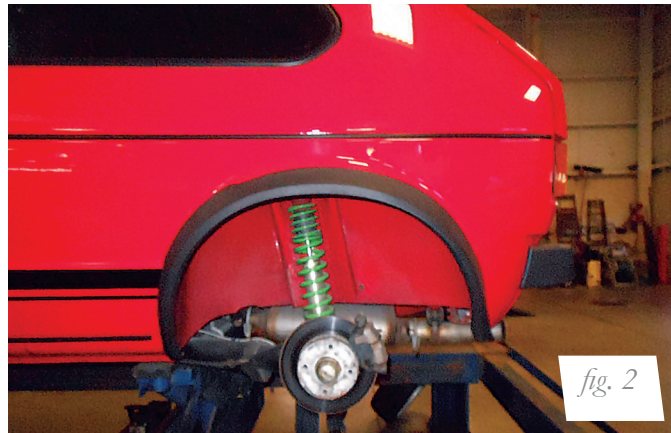

*fig. 2*

## REMOVING THE REAR SUSPENSION

1. Support the hub and remove the shock eye bolt (fig. 3).

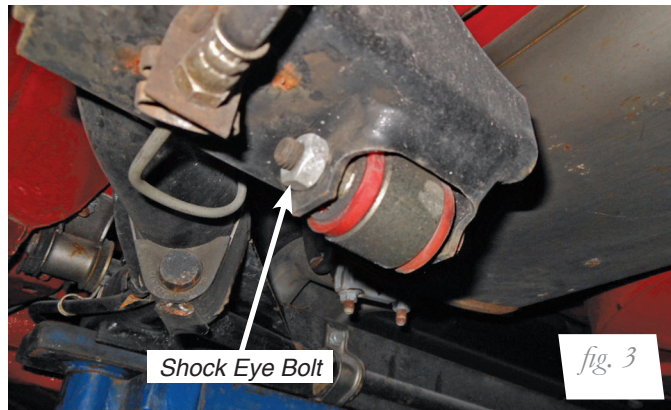

*Shock Eye Bolt*

*fig. 3*

2. Unthread the rod nut and remove the shock from the vehicle (fig. 4). Retain the top rubber isolator and rebound washer.

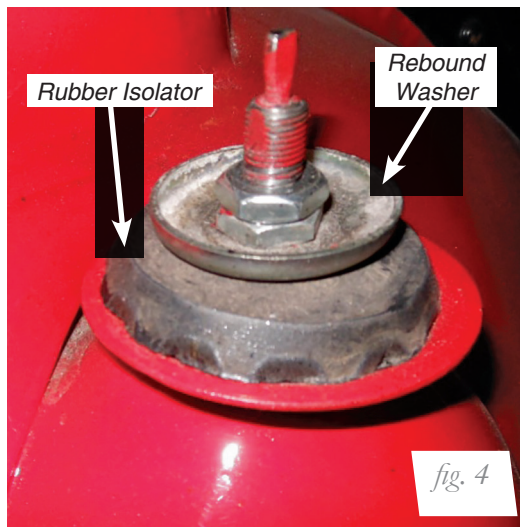

*Rubber Isolator*

*Rebound Washer*

*fig. 4*

3. Remove the rubber isolator from the shock rod and retain for later use (fig. 5).



## AIR SUSPENSION INSTALLATION

1. Install the braided air line into the air spring (fig. 6) with thread sealant, torque 1 3/4 turns beyond hand tight. Attach the desired air fitting to the braided air line with thread sealant, torque 1 3/4 turns beyond hand tight.

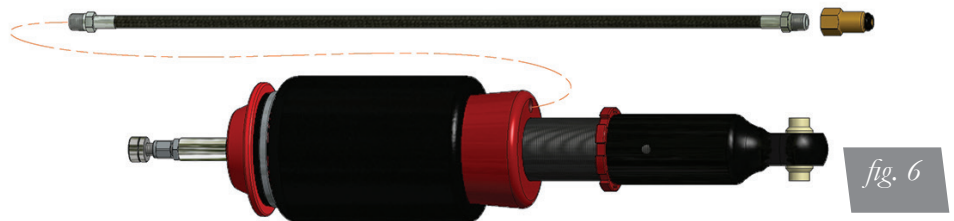

2. Apply the rubber isolator to the shock rod (fig. 7). Insert through the upper shock mounting point (fig. 8) and install the top rubber isolator (fig. 9), rebound washer (fig. 10) and nyloc nut (fig. 11). Torque to 15Nm (11lbs ft) (fig. 12).

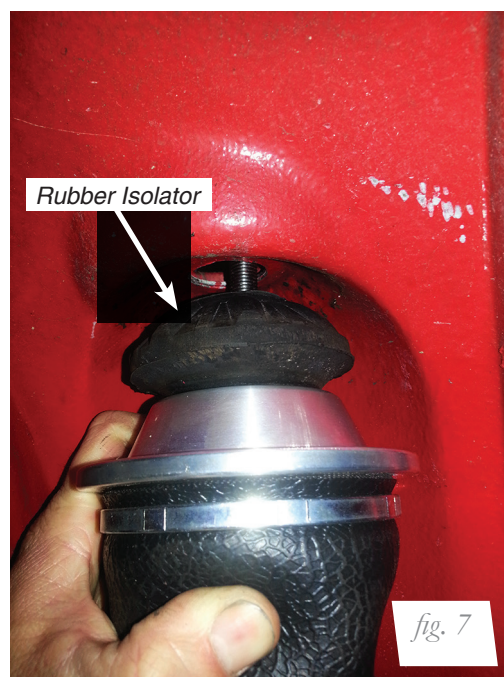



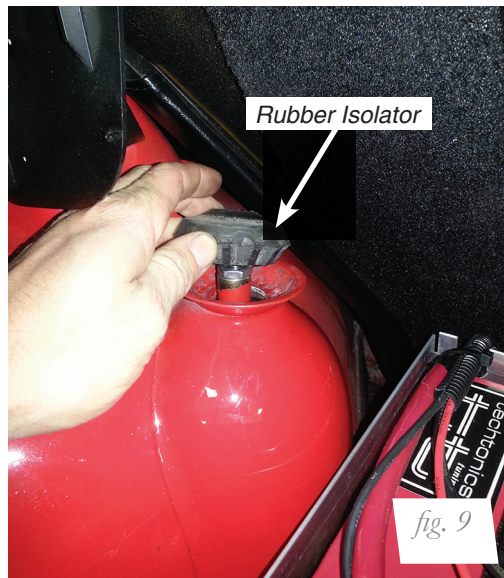
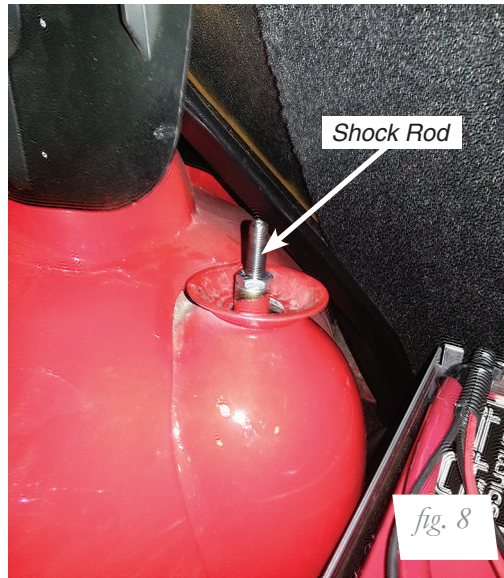

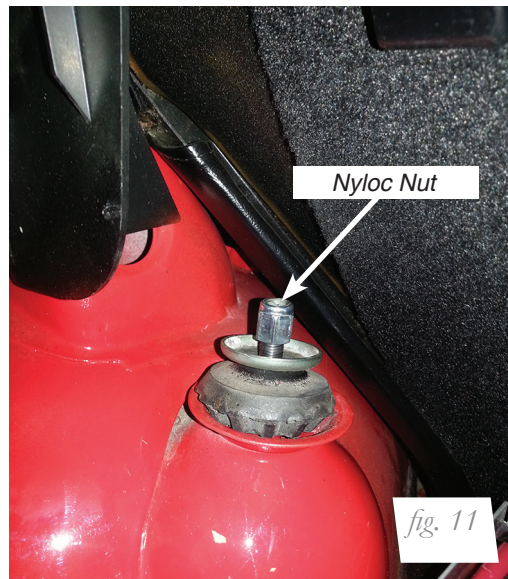

3. Reinstall the lower mount bolt (figs. 13 and 14). Torque to 95Nm (70lbs ft).

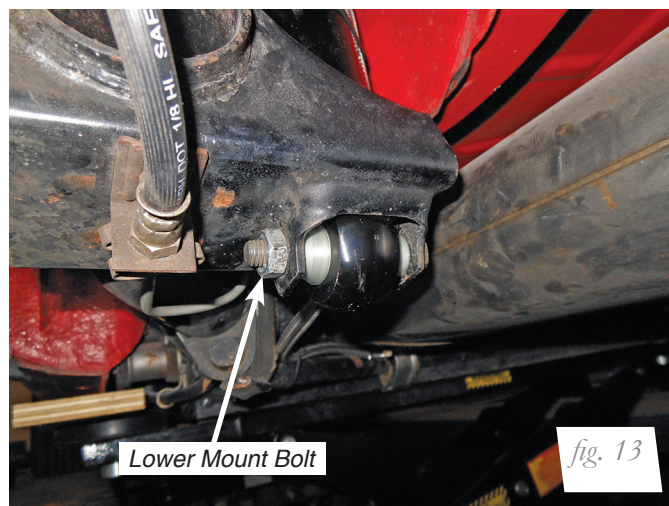





4. Fully compress the suspension using a jack. With the suspension compressed, review the best routing for the leader hose that is clear of all suspension components and axle. Routing should also allow for the suspension to extend without kinking or pulling the line tight or rubbing on other components. Check clearances to all other components.
5. With the suspension fully compressed, take a measurement from the fender to some reference point – typically the center of the axle. Record this measurement as Max Compression.
6. Cycle the suspension to Max Extension and record the measurement from the same reference points.
7. Add ME and MC then divide by 2. Set the suspension to this point. This position will give 50% stroke in either direction and is a starting point for ride height (fig. 15).

**Formula for Calculating Ride Height**

$$(ME+MC) \div 2 = \text{MID STROKE}$$

*fig. 15*

*Table 1*

Torque Specifications		
Location	Nm	lb-ft
Nyloc rod nut	15	11
Lower eye mount bolt/nut	95	70
Wheel studs	110	80
Braided air line threads	1 and 3/4 turns beyond hand tight	

**CAUTION**

IF THE SHOCKS ARE ADJUSTED TO A SHORTER LENGTH, IT MAY BE POSSIBLE TO PINCH THE REAR BRAKE LINE BETWEEN THE AXLE AND THE BODY WHEN FULLY DEFLATED (FIG. 16). PLEASE CHECK FOR CLEARANCE.





## DAMPING ADJUSTMENT

The struts in this kit have 30 settings, or “clicks”, of adjustable compression and rebound damping characteristics. Damping is changed through the strut rod using the supplied adjuster (figs. 17 & 18) or a 3mm allen wrench.

Turn the adjuster clockwise and the damping settings are hardened. Turn the adjuster counterclockwise and the damping is softened.

Each shock is preset to “-20 clicks”. This means that the shock is adjusted 20 clicks away from full stiff. Counting down from full stiff is the preferred method of keeping track of, or setting, damping. This setting was developed on a 1977 Volkswagen Rabbit and may need to be adjusted to different vehicles and driving characteristics.



fig. 17

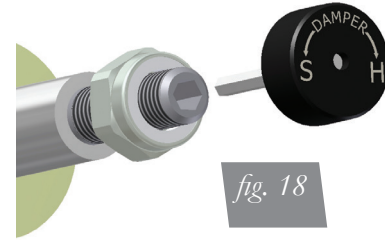

fig. 18

## ALIGNING THE VEHICLE

1. Using the control system, set the vehicle height to the new custom ride height.
2. If the custom ride height is lower than stock, we recommend loosening all pivot points (bolts, nuts) on any control arm, strut arm or radius rod that contains bushings. Once they have been loosened, re-torque to stock specifications.

### NOTE

*It may be necessary to cycle the suspension to loosen the bushing up from its mount. This will help re-orient the bushing at its new position based on the custom ride height.*

## ADJUSTING EXTENDED OR DROP HEIGHT USING LOWER MOUNT

Your struts have been pre-set at the factory to provide maximum drop height while maintaining adequate tire clearance to the air spring. If you wish to gain more extended height (lift), which is the same as reducing drop height, or want to lower the chassis further and there is still adjustment available at the lower mount, please use the following procedure:

1. Support the vehicle with jack stands or a hoist at approved lifting points.
2. Remove the wheel.
3. Using the supplied spanner wrench, loosen the lower locking collar (fig. 19).

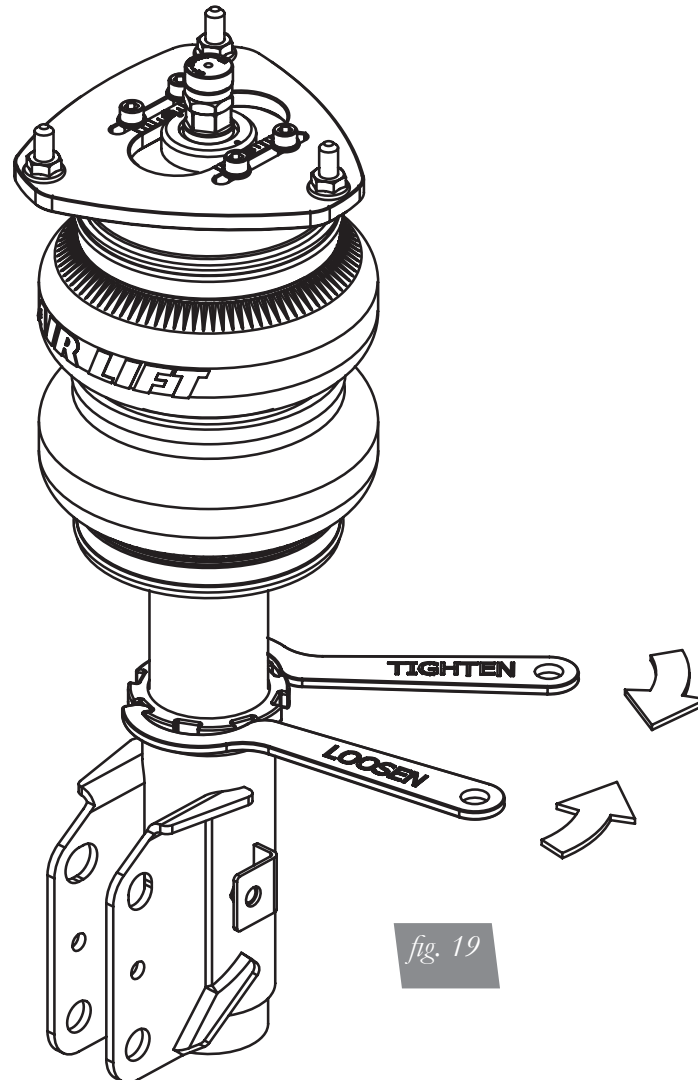

4. Deflate the air spring to 0 PSI on the corner you are adjusting.
5. Disconnect lower mount from suspension.
6. Spin the lower mount to the desired location.

---

### NOTE

*Not all models will have further drop height available.*

7. Re-install lower mount to suspension and torque fasteners.
8. Tighten the lower locking collar to the lower mount using significant force.

## CAUTION

WHEN ADJUSTING HEIGHT UPWARDS, MAKE SURE THAT THE STRUT BODY ENGAGES ALL THE THREADS OF THE LOWER MOUNT (FIG. 20). WHEN ADJUSTING DOWNWARDS, MAKE SURE THERE IS ADEQUATE AIR SPRING CLEARANCE TO THE TIRE/WHEEL ASSEMBLY. CLEARANCE MUST BE CHECKED WITH SYSTEM FULLY DEFLATED AS WELL AS FULLY INFLATED TO ENSURE THAT NO RUBBING OCCURS. FAILURE TO MAINTAIN ADEQUATE CLEARANCE CAN RESULT IN AIR SPRING FAILURE AND WILL NOT BE COVERED UNDER WARRANTY.

## CAUTION

DO NOT ADJUST HEIGHT BY SPINNING AIR SPRING ON STRUT! DOING SO MAY CAUSE AN AIR LEAK AND COMPROMISE THE ASSEMBLY.

### FOR STRUTS:

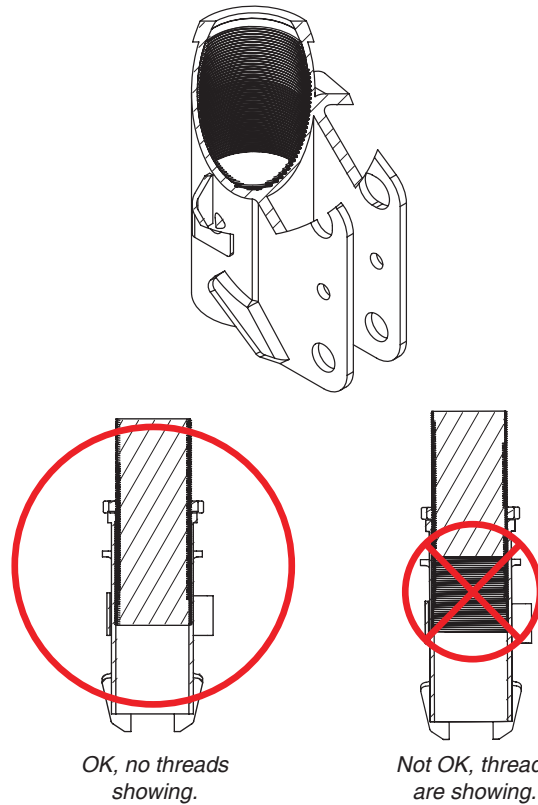

### FOR SHOCKS:

