

Air Lift[™]
PERFORMANCE

Kit 75521

Nissan Z34 370z
Infiniti G37
(except AWD)

Front Application

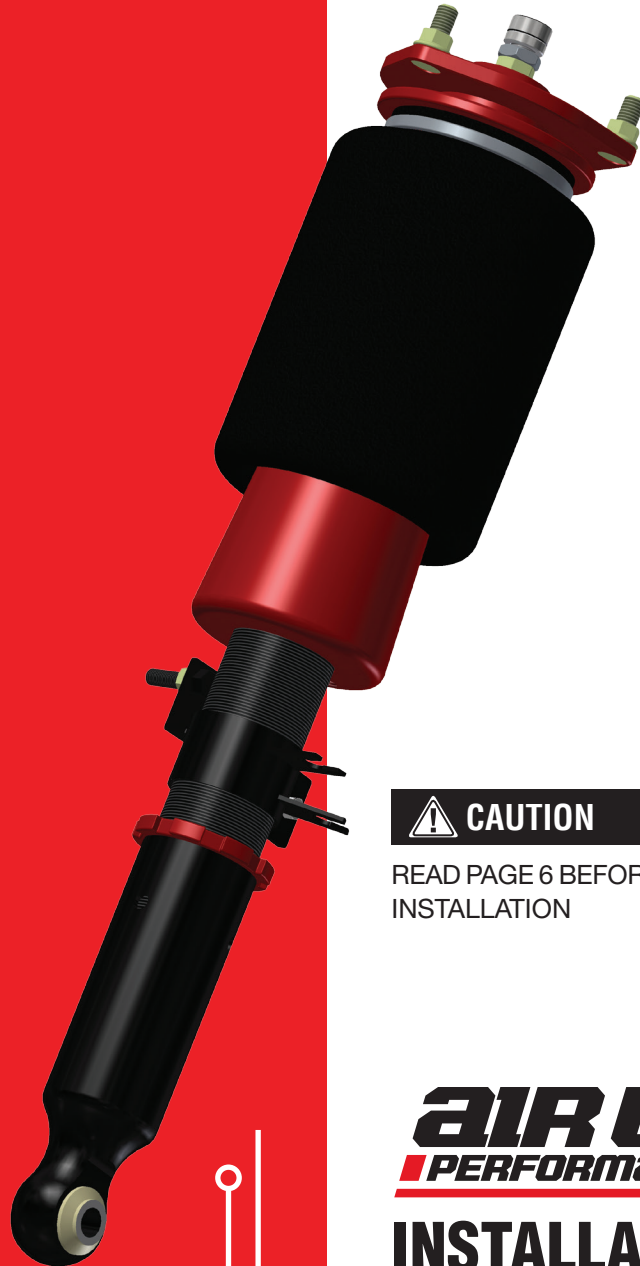

CAUTION

READ PAGE 6 BEFORE
INSTALLATION

AIR LIFT
PERFORMANCE[™]

INSTALLATION GUIDE

For maximum effectiveness and safety,
please read these instructions completely
before proceeding with installation.

*Failure to read these instructions can result in an
incorrect installation.*

PERFORMANCE SUSPENSION PARTS

Introduction

The purpose of this publication is to assist with the installation, maintenance and troubleshooting of this Nissan/Infiniti Performance suspension kit.

It is important to read and understand the entire installation guide before beginning installation or performing any maintenance, service or repair. The information includes a hardware list, step-by-step installation information, maintenance tips, safety information and a troubleshooting guide.

NOTATION EXPLANATION

Hazard notations appear in various locations in this publication. Information which is highlighted by one of these notations must be observed to help minimize risk of personal injury or possible improper installation which may render the vehicle unsafe. Notes are used to help emphasize areas of procedural importance and provide helpful suggestions. The following definitions explain the use of these notations as they appear throughout this guide.

 **DANGER**

INDICATES IMMEDIATE HAZARDS WHICH WILL RESULT IN SEVERE PERSONAL INJURY OR DEATH.

 **WARNING**

INDICATES HAZARDS OR UNSAFE PRACTICES WHICH COULD RESULT IN SEVERE PERSONAL INJURY OR DEATH.

 **CAUTION**

INDICATES HAZARDS OR UNSAFE PRACTICES WHICH COULD RESULT IN DAMAGE TO THE MACHINE OR MINOR PERSONAL INJURY.

NOTE

Indicates a procedure, practice or hint which is important to highlight.

IMPORTANT SAFETY NOTICES

The installation of this kit does not alter the Gross Vehicle Weight Rating (GVWR) or payload of the vehicle. Check your vehicle's owner's manual and do not exceed the maximum load listed for your vehicle.

Gross Vehicle Weight Rating: The maximum allowable weight of the fully loaded vehicle (including passengers and cargo). This number — along with other weight limits, as well as tire, rim size and inflation pressure data — is shown on the vehicle's Safety Compliance Certification Label.

Payload: The combined, maximum allowable weight of cargo and passengers that the vehicle is designed to carry. Payload is GVWR minus the Base Curb Weight.

 **WARNING**

DO NOT INFLATE AIR SPRINGS WHILE OFF OF THE VEHICLE. DAMAGE TO ASSEMBLY MAY RESULT AND VOID WARRANTY.

 **CAUTION**

DO NOT WELD TO, OR MODIFY PERFORMANCE STRUTS/SOCKS IN ANY WAY. DAMAGE TO UNIT MAY OCCUR AND WILL VOID WARRANTY.

Installation Diagram

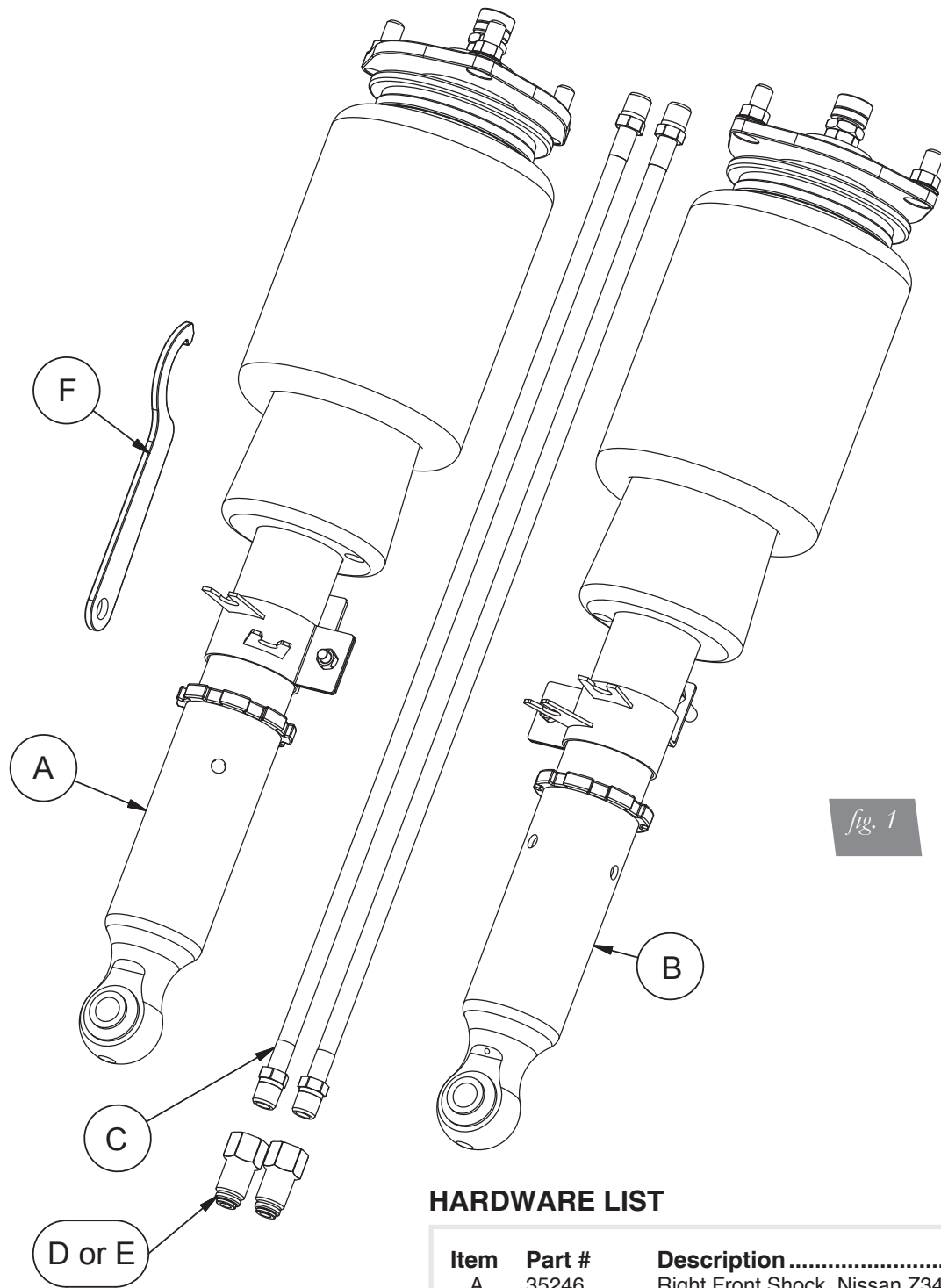

HARDWARE LIST

Item	Part #	Description	Qty
A	35246	Right Front Shock, Nissan Z34	1
B	35247	Left Front Shock, Nissan Z34.....	1
C	20997	Leader Hose, 1/4" NPT	2
D	21810	1/4"FNPT-1/4"PTC Fitting "DOT"	2
E	21987	1/4"FNPT X 3/8"PTC Fitting "DOT"	2
F		Spanner Wrench	1

Installing the Air Suspension

PREPARING THE VEHICLE

1. Elevate and support the vehicle with jack stands or a hoist at approved lifting points.
2. Remove the front wheels.

STOCK SHOCK REMOVAL

1. Support the hub assembly to prevent over-extension of suspension components.
2. Disconnect the stabilizer bar end link from the stabilizer bar. Unthread the lower shock mount nut from the stabilizer bar end link and remove end link from the vehicle (figs. 2-4).



3. Disconnect the wheel speed sensor wire and brake line from the shock (figs. 5 & 6).

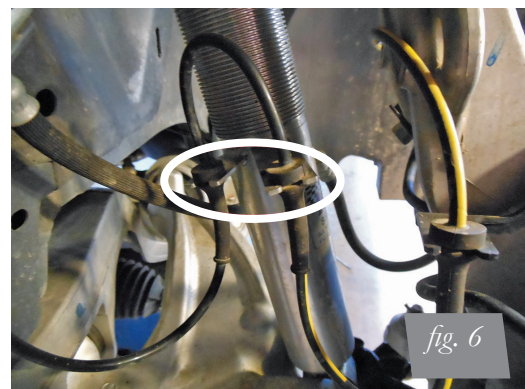

4. Within the engine compartment, unbolt and remove the three shock upper mount bolts. 370z models will need to have the shock tower brace removed to access the upper shock mounts (fig. 7).

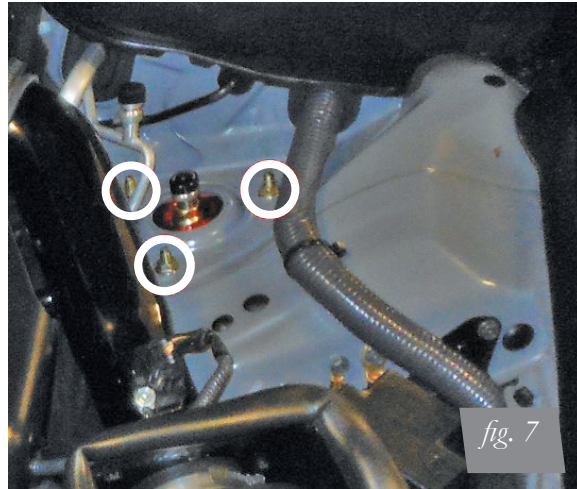

5. Remove shock from the vehicle and remove the thin gasket material from the shock upper bracket and place on the new assembly (fig. 8).



AIR SUSPENSION INSTALLATION

1. Install the leader line into the air spring (fig. 9). Seal the threads of the leader hose with Teflon tape or thread sealant. Tighten the appropriate fitting to the airline 1 3/4 turns beyond hand tight. Tighten the leader line into the air spring 1 3/4 turns beyond hand tight.

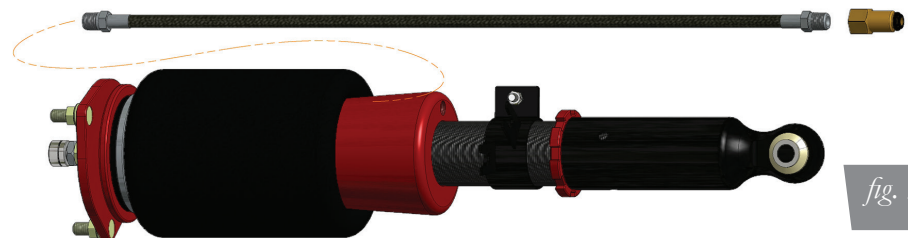

2. Insert the shock assembly into the shock tower and attach the upper bracket to the chassis. The shock should be installed so that the air spring air port is directed towards the engine compartment. Torque the upper bracket nuts to 38.5Nm (28 lb-ft).

3. Attach the shock eye mount to the lower transverse link. Do not torque the attaching bolt at this time.
4. Clip the wheel speed sensor wire onto the bracket on the shock body. Fasten the brake line to this bracket and torque to 22Nm (16 lb-ft).
5. 370z models: Reattach the tower brace. Torque to 45Nm (33 lb-ft).
6. Fully compress the suspension using a jack. With the suspension compressed, review the best routing for the leader hose that is clear of all suspension components and axle. Routing should also allow for the suspension to extend without kinking or pulling the line tight or rubbing on other components. Following the brake line routing is often a good place to start. Check clearances to all other components.

CAUTION

AFTER INITIAL INSTALLATION OF YOUR STRUTS/SHOCKS:

- DO NOT CYCLE THE SUSPENSION WITH THE AIR-LINE CONNECTED TO THE LEADER HOSE WITHOUT FIRST ADDING AIR SPRING PRESSURE. DOING SO MAY CAUSE THE AIR SPRING TO IMPROPERLY INFLATE (FIG.10). IT IS SAFE TO CYCLE THE SUSPENSION TO CHECK FOR CLEARANCES ETC. WITH THE LEADER HOSE OPEN TO ATMOSPHERE (DISCONNECTED FROM AIR-LINE).
- BEFORE SETTING VEHICLE ON THE GROUND FOR THE FIRST TIME, IT IS VERY IMPORTANT TO INFLATE THE AIR SPRINGS TO AT LEAST 50PSI. THIS WILL PREVENT ANY POSSIBILITY OF THE AIR SPRING KICKING OUT AND CAUSING A LEAK (FIG.11).



fig. 10

Caused by cycling with air-line attached without pressure. Remove air-line from spring to release vacuum and re-attach. Inflate to 50+psi before lowering car to ground.



fig. 11

Shows what spring looks like after lowering car to ground with <50psi and raising it with air pressure. Do NOT drive!



fig. 12

Shows what spring looks like when installed correctly.

7. With the suspension fully compressed, take a measurement from the fender to some reference point – typically the center of the axle. Record this measurement as Max Compression.
8. Cycle the suspension to Max Extension and record the measurement from the same reference points.

- Add ME and MC then divide by 2. Set the suspension to this point. This position will give 50% stroke in either direction and is a starting point for ride height (fig. 13).

Formula for Calculating Ride Height

$$(ME+MC)\div 2=MID\ STROKE$$

fig. 13

- With the suspension at this position, loosen, then re-torque the lower control arm bolts to manufacturer's specifications (Table 1).

Torque Specifications		
Location	Nm	lb-ft
Upper bracket to chassis	38.5	28
Upper control arms to bracket	70	52
Transverse link to shock clevis	107	79
Transverse link to subframe	130	96
Stabilizer link to transverse link	87.5	65
Wheels	99-126	73-93
Tower brace	45	33
Brake line bracket nut	22	16

Table 1

DAMPING ADJUSTMENT

The shocks in this kit have 30 settings, or “clicks”, of adjustable compression and rebound damping characteristics. Damping is changed through the shock rod using the supplied adjuster (figs. 14 and 15) or a 3mm allen wrench.

Turn the adjuster clockwise and the damping settings are hardened. Turn the adjuster counterclockwise and the damping is softened.

Each shock is preset to “-18 clicks”. This means that the shock is adjusted 18 clicks away from full stiff. Counting down from full stiff is the preferred method of keeping track of, or setting, damping. This setting was developed on a 2012 Infiniti G37 sedan and may need to be adjusted to different vehicles and driving characteristics.



fig. 14

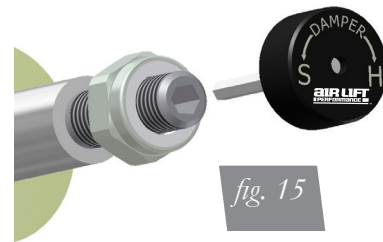

fig. 15

ALIGNING THE VEHICLE

- Using the control system, set the vehicle height to the new custom ride height.
- If the custom ride height is lower than stock, we recommend loosening all pivot points (bolts, nuts) on any control arm, strut arm or radius rod that contains bushings. Once they have been loosened, re-torque to stock specifications.

NOTE

It may be necessary to cycle the suspension to loosen the bushing up from its mount. This will help re-orient the bushing at its new position and increase life of the bushings based on the custom ride height.

ADJUSTING EXTENDED OR DROP HEIGHT USING LOWER MOUNT

Your struts have been pre-set at the factory to provide maximum drop height while maintaining adequate tire clearance to the air spring. If you wish to gain more extended height (lift), which is the same as reducing drop height, or want to lower the chassis further and there is still adjustment available at the lower mount, please use the following procedure:

1. Support the vehicle with jack stands or a hoist at approved lifting points.
2. Remove the wheel.
3. Using the supplied spanner wrench, loosen the lower locking collar (fig. 16).
4. Deflate the air spring to 0 PSI on the corner you are adjusting.
5. Disconnect lower mount from suspension.
6. Spin the lower mount to the desired location.

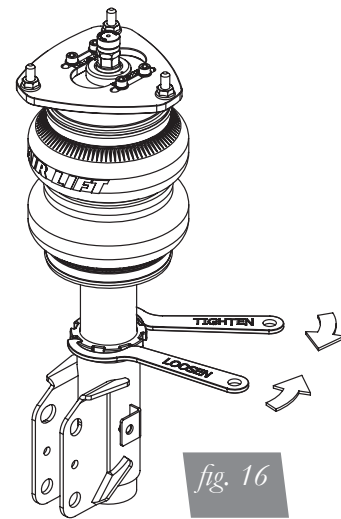

NOTE

Not all models will have further drop height available.

7. Re-install lower mount to suspension and torque fasteners.
8. Tighten the lower locking collar to the lower mount using significant force.

CAUTION

WHEN ADJUSTING HEIGHT UPWARDS, MAKE SURE THAT THE STRUT BODY ENGAGES ALL THE THREADS OF THE LOWER MOUNT (FIG. 17). WHEN ADJUSTING DOWNWARDS, MAKE SURE THERE IS ADEQUATE AIR SPRING CLEARANCE TO THE TIRE/WHEEL ASSEMBLY. CLEARANCE MUST BE CHECKED WITH SYSTEM FULLY DEFLATED AS WELL AS FULLY INFLATED TO ENSURE THAT NO RUBBING OCCURS. FAILURE TO MAINTAIN ADEQUATE CLEARANCE CAN RESULT IN AIR SPRING FAILURE AND WILL NOT BE COVERED UNDER WARRANTY.

CAUTION

DO NOT ADJUST HEIGHT BY SPINNING AIR SPRING ON STRUT! DOING SO MAY CAUSE AN AIR LEAK AND COMPROMISE THE ASSEMBLY.

FOR STRUTS:

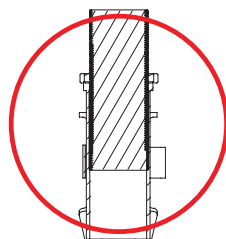
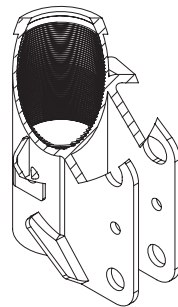

OK, no threads showing.



Not OK, threads are showing.

FOR SHOCKS:

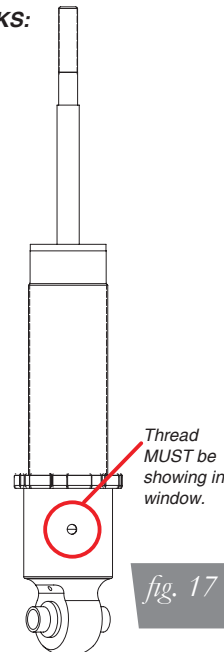

fig. 17