

***Air Lift*1000**

by AIR LIFT®

Kit 60814

Dodge Caravan & Grand Caravan, Chrysler Town & Country, Volkswagon Routan



Cover illustration may not depict actual kit.



INSTALLATION GUIDE

For maximum effectiveness and safety, please read these instructions completely before proceeding with installation.

Failure to read these instructions can result in an incorrect installation.

Introduction

The purpose of this publication is to assist with the installation, maintenance and troubleshooting of the Air Lift 1000 air spring kit.

It is important to read and understand the entire installation guide before beginning installation or performing any maintenance, service or repair. The information here includes a hardware list, tools list, step-by-step installation information, maintenance guidelines and operating tips.

IMPORTANT SAFETY NOTICE

The installation of this kit does not alter the Gross Vehicle Weight Rating (GVWR) or payload of the vehicle. Check your vehicle's owner's manual and do not exceed the maximum load listed for your vehicle.

Gross Vehicle Weight Rating: The maximum allowable weight of the fully loaded vehicle (including passengers and cargo). This number — along with other weight limits, as well as tire, rim size and inflation pressure data — is shown on the vehicle's Safety Compliance Certification Label.

Payload: The combined, maximum allowable weight of cargo and passengers that the truck is designed to carry. Payload is GVWR minus the Base Curb Weight.

NOTATION EXPLANATION

Hazard notations appear in various locations in this publication. Information which is highlighted by one of these notations must be observed to help minimize risk of personal injury or possible improper installation which may render the vehicle unsafe. Notes are used to help emphasize areas of procedural importance and provide helpful suggestions. The following definitions explain the use of these notations as they appear throughout this guide.

 **DANGER**

INDICATES IMMEDIATE HAZARDS WHICH WILL RESULT IN SEVERE PERSONAL INJURY OR DEATH.

 **WARNING**

INDICATES HAZARDS OR UNSAFE PRACTICES WHICH COULD RESULT IN SEVERE PERSONAL INJURY OR DEATH.

 **CAUTION**

INDICATES HAZARDS OR UNSAFE PRACTICES WHICH COULD RESULT IN DAMAGE TO THE MACHINE OR MINOR PERSONAL INJURY.

NOTE

Indicates a procedure, practice or hint which is important to highlight.

HARDWARE LIST

Item	Part #	Description.....Qty
A	46141	Air spring.....2
B	20315	Hose 15'.....1
C	10466	Tie strap.....4
D	21230	Valve cap.....2
E	21233	5/16" Hex nut.....4
F	21234	Rubber washer.....2
G	18411	Star washer.....2
H	18405	5/16" Flat washer.....2
I	21236	Tee.....4
J	21455	Valve.....4
K	33107	Heat shield kit.....1

TOOLS LIST

Description.....Qty
Hoist or floor jacks.....2
Safety stands.....1
Safety glasses.....1
Metric and standard sockets/ratchet and wrenches.....1
Drill, drill bits.....1
Grinder or dremel tool.....1
Pliers.....1
Air compressor or compressed air source.....1
Spray bottle with dish soap/water solution.....1

Installing the Air Lift 1000 System

PREPARING THE VEHICLE

1. Jack up the rear of the vehicle or raise on a hoist. Support the frame with safety stands so that the wheels hang (fig. 1).

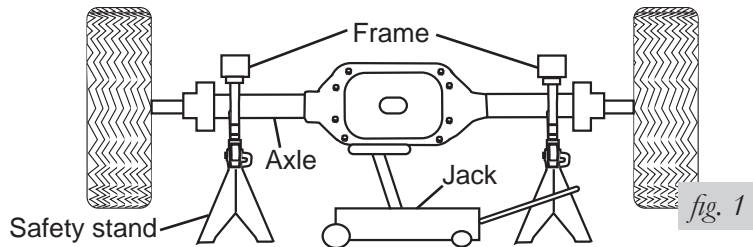

2. Unbolt the brake line bracket and disconnect the brake line from the clip on the side of the frame. Do this on both sides of the vehicle (fig. 2). Disconnect the lower shocks from the suspension cross member.

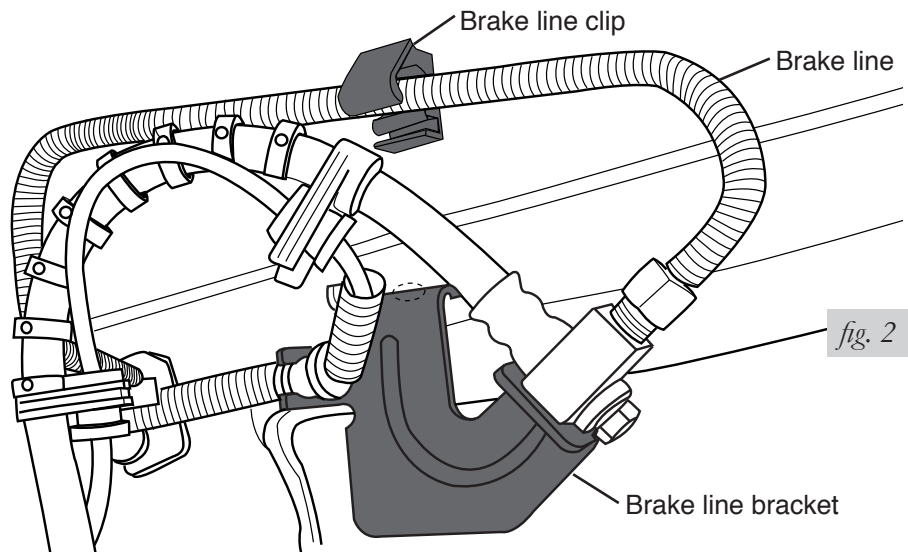

- The coil spring will have to be removed to prep the vehicle for the air spring. Mark the coil spring, upper spring damper and upper spring seat with a marker so that the assembly can be put back in the same orientation (fig. 3).

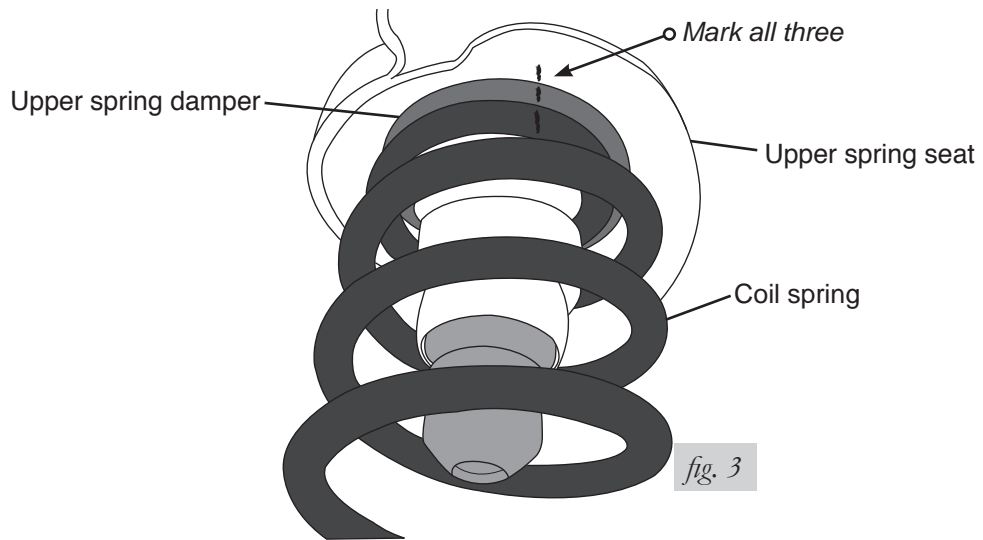

- Drop the rear suspension down far enough to remove the springs from the vehicle.
- Once the springs are removed, pull the lower plastic jounce bumper strike plate off the spring. Pull sideways on the jounce bumper while twisting and remove the jounce bumper from the upper jounce bumper bracket (fig. 4).

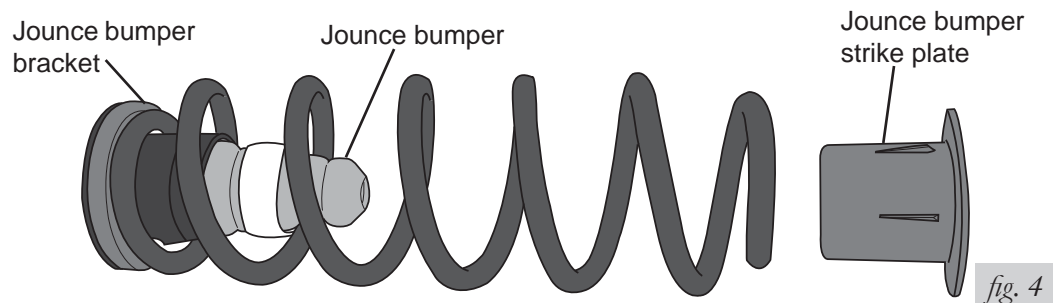

- It will be necessary to enlarge the center hole in the upper jounce bumper bracket. Drill the existing hole out with a 1/2" drill bit (fig. 5).

NOTE

It may be necessary to clean the loose plastic out with a knife or a file. The hole must be open and not restrictive so the hose can flow freely in and out.

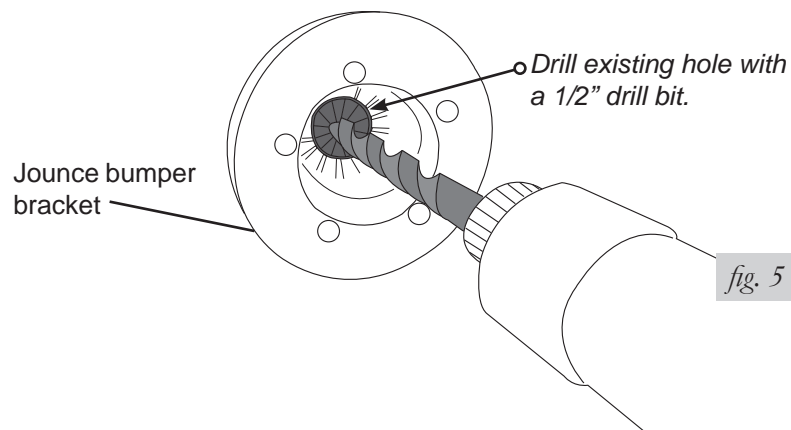

- It will also be necessary to enlarge the upper spring seat hole. Drill the existing hole out with a 1/2" drill bit (fig. 6).

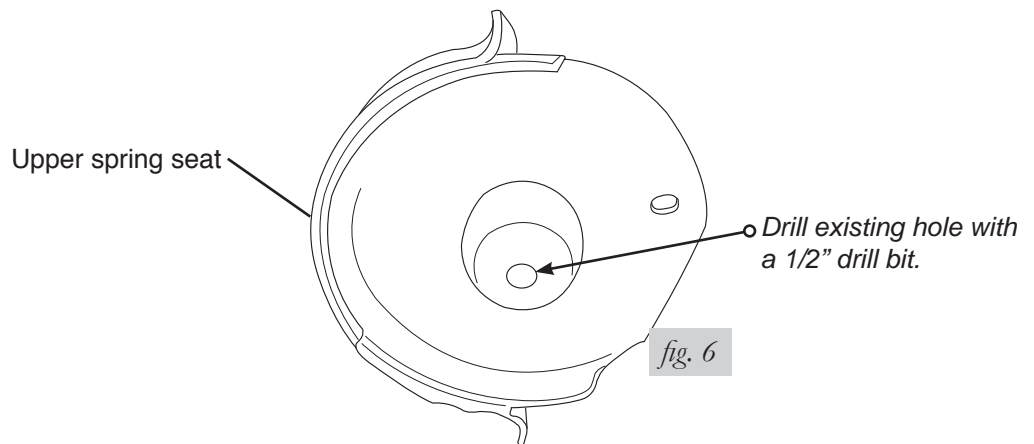

- You will need to drill a hole through the upper spring seat frame reinforcement in order to gain access to the cylinder for the hose. Measure up from the bottom edge of the reinforcement 3.5" at the center of the spring (fig. 7).

NOTE

Error to the rear of the center if needed. Mark and drill a 1/2" hole through the reinforcement only.

- Install the supplied grommet into the hole previously drilled. Repeat steps 5-9 for the opposite side.

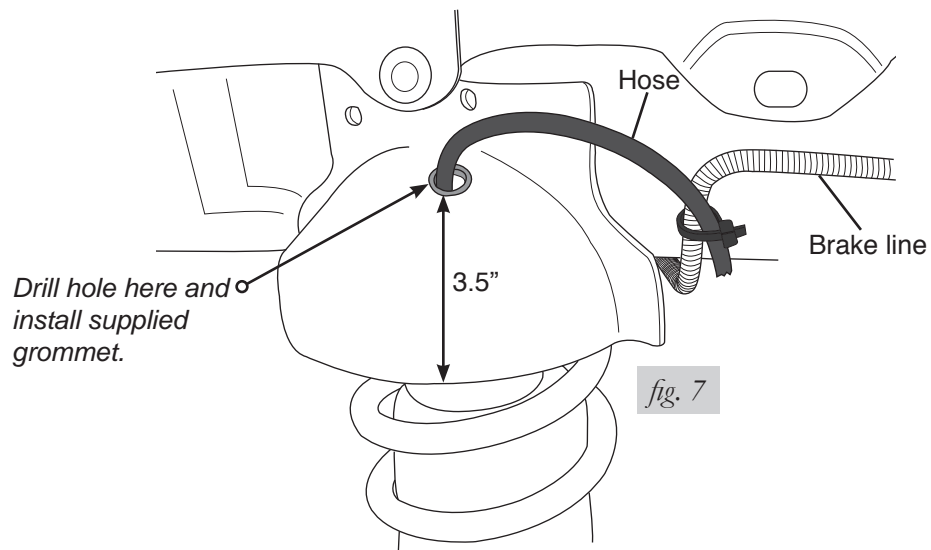

INSTALLING THE AIR SPRING

- Insert the air springs into the coil springs with the stem pointing up. Reinstall the spring back into the suspension, lining up the marks made in step 3. Raise the suspension up just enough to hold the spring in place.
- When installing the hose it may be necessary to insert the hose through the bottom of the jounce bumper bracket, up through the hole in the grommet that was installed previously.

NOTE

If you find it hard to get the hose through the grommet it may be helpful to use a stiff wire to guide the hose up through the hole. Attach the hose to the barbed end of the cylinder using the hose clamp provided.

INSTALLING THE AIR LINE

A tee air line installation is recommended. If the weight in the vehicle varies from one side to the other and unequal pressures are needed to level the load or compensate for axle torque transfer in racing applications, use dual air lines (see page 8).

TEE AIR LINE ROUTING

CAUTION

TO PREVENT THE AIR LINE FROM MELTING, MAINTAIN AT LEAST 8" FROM THE EXHAUST SYSTEM TO THE AIR LINE.

1. Locate the desired tee location on the frame rail or cross member. Determine and cut an adequate length of air line to reach from the tee to the left and right side air springs.

CAUTION

LEAVE SUFFICIENT AIR LINE SLACK TO PREVENT ANY STRAIN ON THE FITTING DURING AXLE MOTIONS.

2. Slide an air line clamp onto the air line.
3. Push the air line over one side of the tee until all the barbs are covered. With a pair of pliers, slide the air line clamp forward until it fully covers the barbed section. Repeat the entire procedure for the other leg of the tee (fig. 8).
4. Route the air line along the cross member and either the lower control arm or the upper spring seat to the air spring.

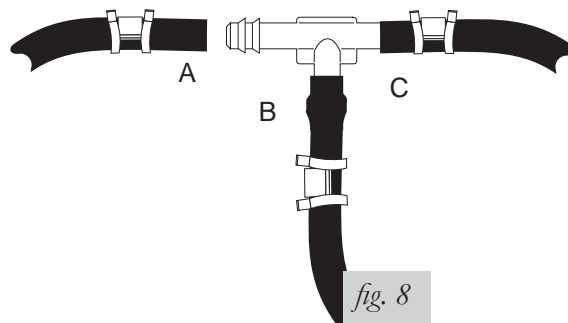

Use this procedure for all air line connections:

- a. Slide the air line clamp onto the air line.
- b. Push the air line over the barbed stem.
- c. Compress the ears on the air line clamp with pliers and slide it forward to fully cover the barbed section.

5. Insert the air line through the spring seat and spacers.
6. Push the air line onto the stem, covering all the barbs (fig. 9). With the pliers, slide the air line clamp upward until it fully covers the barbed section.

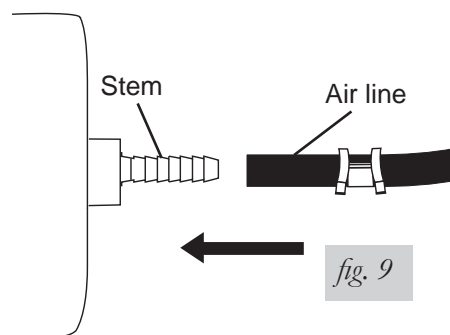

7. Push the remaining air line over the last fitting on the tee and route it along the frame to the desired inflation valve location. Attach the air line with plastic straps or wire.
8. Select a location for the inflation valve in the gas cap well, the trunk, rear bumper, fender flange or behind the license plate, insuring that the valve will be protected and accessible with an air hose (fig. 10).

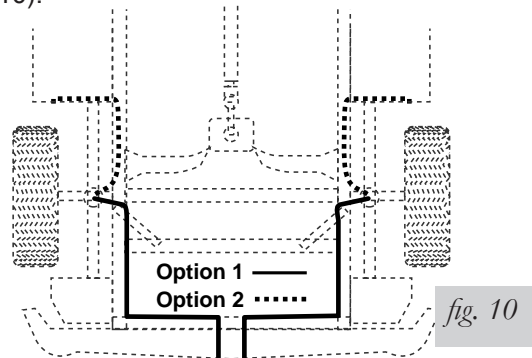

9. Drill a 5/16" hole for the inflation valve and mount as shown (fig. 11). The rubber washer serves as an outside weather seal.
10. Slide the air line clamp over the air line. Push the air line onto the fitting covering all barbs. Using pliers, slide the air line clamp forward until it fully covers the barbed section (fig. 12).

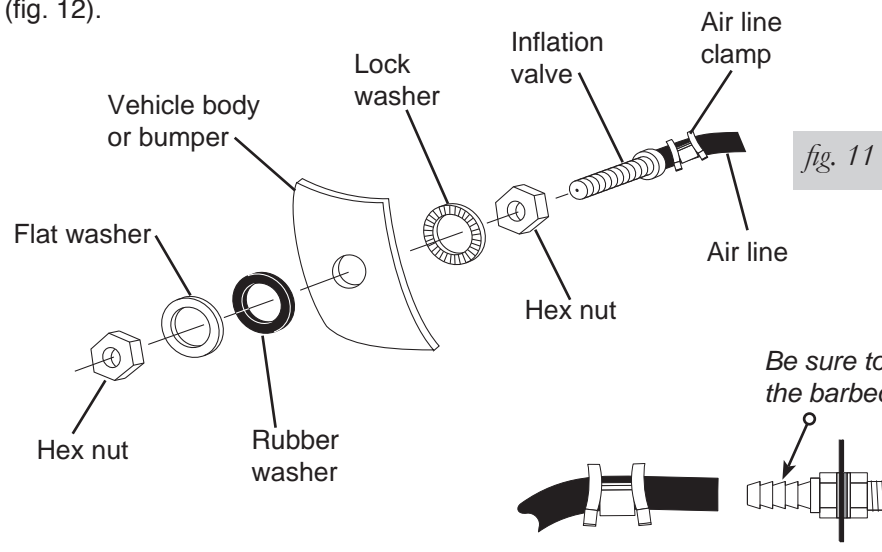

13. Raise the axle or lower the vehicle body until the air springs lightly touch the upper spring seat and lower spacers.
14. Check the tail pipe clearance and insure that it is at least 2-3 inches from the air spring. If necessary, loosen the clamps and rotate or move to obtain additional clearance. Reattach the shock absorbers if removed earlier in the installation.

CAUTION

DO NOT INFLATE AIR SPRINGS BEFORE READING THE MAINTENANCE AND OPERATION SECTION.

15. Continue to "Completing the Installation."

DUAL AIR LINE ROUTING

CAUTION

TO PREVENT AIR LINE FROM MELTING, KEEP IT AT LEAST 8" FROM EXHAUST SYSTEM.

1. Select a location for the inflation valves in the rocker panel flange, or rear bumper, assuring that each valve will be protected and accessible with an air hose.
2. Determine and cut an adequate length of air line to reach from the valve location to the left side air spring.

CAUTION

LEAVE SUFFICIENT AIR LINE SLACK TO PREVENT ANY STRAIN ON FITTING DURING AXLE MOTIONS.

3. Insert the air line through the spring seat and spacer.
4. Slide the air clamp onto the cut air line.
5. Push the air line onto the stem, covering all the barbed section (see fig. 9). With pliers slide the air line clamp forward until it fully covers the barbed section.
6. Repeat process for the right side.
7. Drill a 5/16 " hole for the inflating valves and mount as illustrated. The rubber washer is for an outside weather seal (see fig. 11).
8. Route the air line along the control arm and frame to the inflation valve location and cut off the excess.
9. Slide a clamp onto the air line and push the air line over the fitting, covering all the barbs. With pliers slide the air line clamp forward until it fully covers the barbed section (see fig. 12).
10. Raise the axle or lower body until the air springs lightly touch the upper spring seat and lower spacers.
11. Check the tail pipe clearance and insure that it is at least 2-3 inches from the air springs. If necessary, loosen the clamps and rotate or move to obtain additional clearance. If you are installing this kit on a Honda Odyssey see page 6 for instruction on how to install the heat shield. Reattach the shock absorbers if removed earlier in the installation.

CAUTION

DO NOT INFLATE AIR SPRINGS BEFORE READING THE MAINTENANCE AND OPERATION SECTION.

COMPLETING THE INSTALLATION

1. Raise the suspension all the way up and attach the brake line bracket, clip the brake line into the clamp on the side of the frame and reattach the shocks.

NOTE

Be sure that the hose does not kink during this process.

2. Leave slack at the top for the hose to move in and out freely during normal driving and in case the vehicle is serviced on a frame contact hoist (fig. 7).

NOTE

Loosely attach the hose to the brake line using a wire tie.

3. Inflate the air springs to 35 PSI. Test for air leaks by applying a liquid solution of $\frac{1}{5}$ dish soap to $\frac{4}{5}$ water to all valve cores, fittings and connections.
4. Lower the vehicle to the ground. Read Maintenance/Operation Tips for proper care of your air springs.
5. Recheck air pressure after 24 hours. A 2-4 PSI loss after initial installation is normal. If pressure has dropped more than 5 lbs, retest for leaks.

Maintenance and Servicing

Minimum Air Pressure	Maximum Air Pressure
5 PSI	35 PSI
FAILURE TO MAINTAIN CORRECT MINIMUM PRESSURE (OR PRESSURE PROPORTIONAL TO LOAD), BOTTOMING OUT, OVER-EXTENSION OR RUBBING AGAINST ANOTHER COMPONENT WILL VOID THE WARRANTY.	

MAINTENANCE GUIDELINES

By following these steps, vehicle owners will obtain the longest life and best results from their air springs.

1. Check the air pressure weekly.
2. Always maintain at least the recommended minimum air pressure to prevent the air spring from being pinched. Never inflate beyond the maximum air pressure.
4. If you develop an air leak in the system, use a soapy water solution of 1/5 liquid dish soap and 4/5 water to check all air line connections and the inflation valve core before deflating and removing the air spring.
5. Always add air to springs in small quantities, checking the pressure frequently. Sleeves require less air volume than a tire and inflate quickly.

OPERATING TIPS

1. Inflate your air springs to 35 PSI before adding the payload. This will allow the air cylinder to properly mesh with the coil spring. After the vehicle is loaded, adjust your air pressure down to level the vehicle and for ride comfort.
2. When carrying a payload it will be helpful to increase the tire inflation pressure in proportion to any overload condition. We recommend a 2 PSI increase above normal for each 100 lbs additional load on the axle.



CAUTION

DO NOT EXCEED THE VEHICLE MANUFACTURERS' MAXIMUM GROSS VEHICLE WEIGHT RATING.

Product Use

FREQUENTLY ASKED QUESTIONS

Q. Will installing air springs increase the weight ratings of a vehicle?

No. Adding air springs will not change the weight ratings (GAWR, GCWR and/or GVWR) of a vehicle. Exceeding the GVWR is dangerous and voids the Air Lift warranty.

Q. Is it necessary to keep air in the air springs at all times and how much pressure will they need?

The minimum air pressure should be maintained at all times. The minimum air pressure keeps the air spring in shape, ensuring that it will move throughout its travel without rubbing or wearing on itself.

Q. Is it necessary to add a compressor system to the air springs?

No. Air pressure can be adjusted with any type of compressor as long as it can produce sufficient pressure to service the springs. Even a bicycle tire pump can be used, but it's a lot of work.

Q. How long should air springs last?

If the air springs are properly installed and maintained they can last indefinitely.

Q. Will raising the vehicle on a hoist for service work damage the air springs?

No. The vehicle can be lifted on a hoist for short-term service work such as tire rotation or oil changes. However, if the vehicle will be on the hoist for a prolonged period of time, support the axle with jack stands in order to take the tension off of the air springs.

TUNING THE AIR PRESSURE

Pressure determination comes down to three things — level vehicle, ride comfort, and stability.

1. Level vehicle

If the vehicle's headlights are shining into the trees or the vehicle is leaning to one side, then it is not level (fig. 13). Raise the air pressure to correct either of these problems and level the vehicle.

2. Ride comfort

If the vehicle has a rough or harsh ride it may be due to either too much pressure or not enough (fig. 14). Try different pressures to determine the best ride comfort.

3. Stability

Stability translates into safety and should be the priority, meaning the driver may need to sacrifice a perfectly level and comfortable ride. Stability issues include roll control, bounce, dive during braking and sponginess (fig. 15). Tuning out these problems usually requires an increase in pressure.



Bad headlight aim

fig. 13



Rough ride

fig. 14



Sway and body roll

fig. 15

GUIDELINES FOR ADDING AIR

1. Start with the vehicle level or slightly above.
2. When in doubt, always add air.
3. For motorhomes, start with 50-100 PSI in the rear because it can be safely assumed that it is heavily loaded.
4. If the front of the vehicle dives while braking, increase the pressure in the front air bags, if equipped.
5. If it is ever suspected that the air bags have bottomed out, increase the pressure (fig. 16).
6. Adjust the pressure up and down to find the best ride.
7. If the vehicle rocks and rolls, adjust the air pressure to reduce movement.
8. It may be necessary to maintain different pressures on each side of the vehicle. Loads such as water, fuel, and appliances will cause the vehicle to be heavier on one side (fig. 17). As much as a 50 PSI difference is not uncommon.

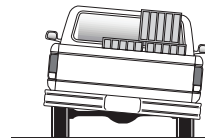

Bottoming out

fig. 16

Unlevel

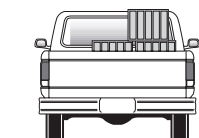

Level

fig. 17