

# LoadLIFTER™ 5000

by AIR LIFT®

# Kit 57397

**Ford F-250/F-350**  
*(Single and Dual Rear Wheel)*  
**2-Wheel Drive**



## INSTALLATION GUIDE

For maximum effectiveness and safety, please read these instructions completely before proceeding with installation.

*Failure to read these instructions can result in an incorrect installation.*

# Introduction

The purpose of this publication is to assist with the installation, maintenance and troubleshooting of the LoadLifter 5000 air spring kit. LoadLifter 5000 utilizes sturdy, reinforced, commercial grade single or double, depending on the kit, convolute bellows. The bellows are manufactured like a tire with layers of rubber and cords that control growth. LoadLifter 5000 kits are recommended for most 3/4 and 1 ton pickups and SUVs with leaf springs and provide up to 5,000 lbs. of load leveling support with air adjustability from 5-100 PSI. The kits are also used in motor home rear kits and some motor home fronts where leaf spring are used.

It is important to read and understand the entire installation guide before beginning installation or performing any maintenance, service or repair. The information here includes a hardware list, tool list, step-by-step installation information, maintenance guidelines and operating tips.

## IMPORTANT SAFETY NOTICE

The installation of this kit does not alter the Gross Vehicle Weight Rating (GVWR) or payload of the vehicle. Check your vehicle's owner's manual and do not exceed the maximum load listed for your vehicle.

**Gross Vehicle Weight Rating:** The maximum allowable weight of the fully loaded vehicle (including passengers and cargo). This number — along with other weight limits, as well as tire, rim size and inflation pressure data — is shown on the vehicle's Safety Compliance Certification Label.

**Payload:** The combined, maximum allowable weight of cargo and passengers that the truck is designed to carry. Payload is GVWR minus the Base Curb Weight.

## NOTATION EXPLANATION

Hazard notations appear in various locations in this publication. Information which is highlighted by one of these notations must be observed to help minimize risk of personal injury or possible improper installation which may render the vehicle unsafe. Notes are used to help emphasize areas of procedural importance and provide helpful suggestions. The following definitions explain the use of these notations as they appear throughout this guide.



### DANGER

INDICATES IMMEDIATE HAZARDS WHICH WILL RESULT IN SEVERE PERSONAL INJURY OR DEATH.



### WARNING

INDICATES HAZARDS OR UNSAFE PRACTICES WHICH COULD RESULT IN SEVERE PERSONAL INJURY OR DEATH.



### CAUTION

INDICATES HAZARDS OR UNSAFE PRACTICES WHICH COULD RESULT IN DAMAGE TO THE MACHINE OR MINOR PERSONAL INJURY.

---

## NOTE

*Indicates a procedure, practice or hint which is important to highlight.*

---

# Installation Diagram

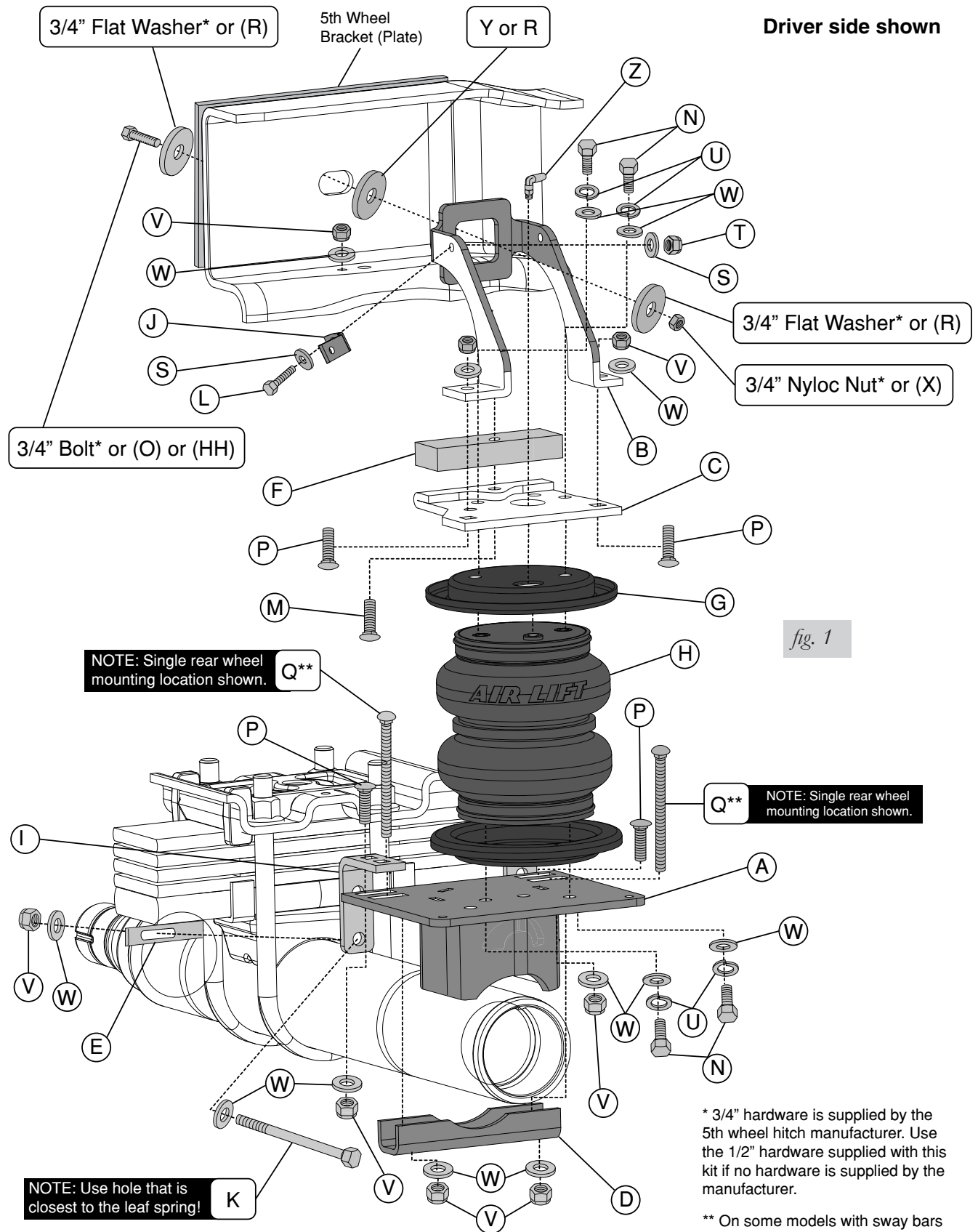

# Hardware and Tools Lists

## HARDWARE LIST

Item	Part #	Description .....	Qty	Item	Part #	Description .....	Qty
A	03991	Lower Bracket.....	2	R	18207	1/2" Thick Flat Washer.....	6
B	07996	Upper Brace.....	1	S	18419	Flat Washer #12.....	2
C	07997	Upper Bracket.....	1	T	18425	1/4"-20 Nyloc Nut.....	1
D	01531	Clamp Bar.....	2	U	18427	3/8" Lock Washer.....	8
E	10861	Spring Clamp Bar.....	2	V	18435	3/8"-16 Nyloc Nut.....	18
F	13966	Spacer.....	2	W	18444	3/8" Flat Washer.....	34
G	11951	Roll Plate.....	4	X	18460	1/2-13" Nyloc Nut.....	2
H	58437	Bellows.....	2	Y	18556	3/4" Flat Washer.....	2
I	10880	Four Hole Locating Bracket.....	4	Z	21837	90 ° Swivel Air Fitting.....	2
J	10886	"L" Bracket.....	1	AA	10466	Zip Ties.....	6
K	17110	3/8-16 x 5.5 Hex Head Cap Screw.....	4	BB	18411	5/16" Lock Washer.....	2
L	17135	1/4"-20 x 1" Hex Cap Screw.....	1	CC	21230	Valve Caps.....	2
M	17141	3/8-16 x 2.5" Carriage Bolt.....	2	DD	21233	5/16" Hex Nut.....	2
N	17203	3/8-24 x 7/8" Hex Head Cap Screw.....	8	EE	21234	Rubber Washer.....	2
O	17271	1/2"-13 x 3" Hex Cap Screw.....	2	FF	20086	Air Line Assembly.....	1
P	17361	3/8-16 x 1.25" Carriage Bolt.....	8	GG	34924	Heat Shield Kit.....	1
Q	17387	3/8-16 x 10" Carriage Bolt.....	4	HH	17208	1/2-13 x 2" Hex Head Cap Screw.....	2

## TOOLS LIST

Description.....	Qty
7/16" and 9/16" Open-end or box wrenches.....	2
Crescent wrench.....	1
Ratchet with 3/8", 9/16", & 1/2" deep well sockets.....	1
5/16" drill bits (very sharp).....	1
DIR grinder.....	1
Hacksaw.....	1
Heavy duty drill.....	1
Torque wrench.....	1
Standard, metric and SAE sockets and wrenches.....	1
Hose cutter, razor blade, or sharp knife.....	1
Hoist or floor jacks.....	1
Safety stands.....	1
Safety glasses.....	1
Air compressor or compressed air source.....	1
Spray bottle with dish soap/water solution.....	1

# Installing the LoadLifter 5000 System

## GETTING STARTED

1. Raise the vehicle and support the axle with jack stands, setting the jack stands as wide as possible on the axle (fig. 2).

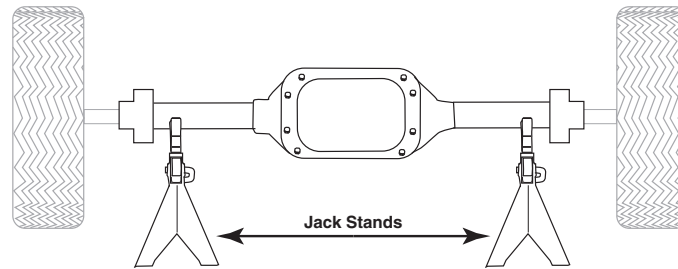

fig. 2

2. Remove the jounce bumpers from under the frame, over the axle.
3. If necessary, disconnect the wiring harness from the driver side frame rail to gain clearance for the upper bracket.
4. For all dual rear wheel vehicles (DRW) it will be necessary to remove the sway bar strap and bolts holding the sway bar to the axle. Retain for later reinstallation.
5. If you have a fifth wheel hitch already installed, it will be necessary to remove the  $\frac{3}{4}$ " hardware that bolts the side bracket to the outside of the frame above the axle (fig. 1).

### NOTE

*Some hitch models have a spacer between the bracket and the frame rail. Be sure to reinstall the spacer when attaching the upper bracket.*

### NOTE

*If your model truck has emission lines running along the inside of the frame rail (fig. 3), it will be necessary to relocate those lines as follows. Follow the directions in the section, "Attaching the Assemblies to the Frame" for reattaching these lines.*

- *Carefully push the line holder out of the frame above the axle. Try to minimize damage because it will be reused later. It may also be helpful to remove any holders forward or rearward of the axle to aid in positioning the lines once the upper bracket has been installed (fig. 3).*
- *Attach the L-bracket (J) to the back frame brace using the 1/4" bolt (L), flat washers (S) and nyloc nut (T) supplied (fig. 1). This L-bracket will eventually be used to attach the previously removed emissions line. Do not attach the line holder to it at this time.*

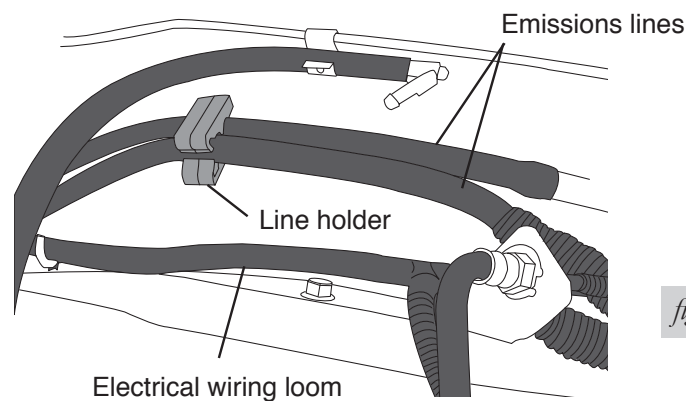
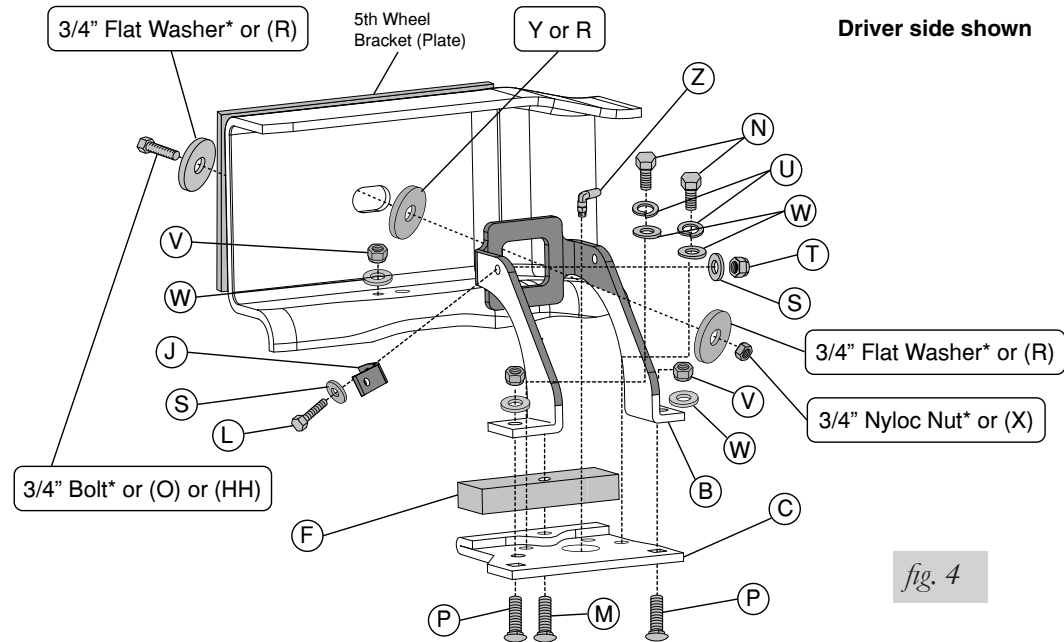

fig. 3

## SIDE BRACE INSTALLATION



1. Set the upper brace (B) into the driver and passenger side frame (fig. 4).

If you have a fifth wheel hitch that does not have a plate running alongside the full length of the frame (these will have an “L” bracket forward and behind the axle leaving the middle frame open) use the 1/2-13 x 2.00” Hex Cap Screw (HH) with a flat washer (R) through the slot in the side of the frame, then through another flat washer (R) and finally through the upper brace. Cap with a flat washer (R) and a 1/2-13 nyloc nut (X) (fig. 5). Leave loose at this time.

OR

If you have an aftermarket fifth wheel hitch that has a bracket (plate) running along side of the frame and it used this slot to secure the bracket to the frame with existing hardware, install the existing hardware previously removed in the “getting started section” from the fifth wheel installation for securing the brace (fig. 4). Make sure to install the large 3/4” flat washer (Y) between the brace and frame (figs. 1 and 4). Do not tighten at this time.

OR

If you have an aftermarket fifth wheel hitch that has a bracket (plate) running along side of the frame and it does not have any attaching hardware on the side where the slot in the frame is, it will be necessary to drill a 1/2” hole through the plate using the slot in the frame as a template. Drill the hole as far back in the slot as you can.

### NOTE

*It may be necessary to mark and remove the bracket (plate) from the side of the frame in order to drill the hole correctly. Re-attach once the hole is drilled.*

Insert a 1/2”-13 x 3.00” hex cap screw (O) with a flat washer (R) through the fifth wheel plate previously drilled, the frame, then through another flat washer (R) and finally the upper frame brace. Cap with a flat washer (R) and a 1/2”-13 Nyloc nut (X) (fig. 4). Leave loose at this time.

## BELLOWS AND BRACKET ASSEMBLY

1. Set a roll plate (G) over the top and bottom of the bellows (H) (fig. 1).

**NOTE**

*The radiused (rounded) edge of the roll plate (G) will be towards the bellows so that the bellows is seated inside both roll plates.*

2. Install the swivel elbow fitting (Z) into the top of the bellows finger tight. Tighten the swivel fitting one and a half turns.
3. The lower bracket (A) has two sets of bellows mounting holes. Using the corresponding holes in the lower bracket designated (fig. 5), attach the bellows to the brackets using the 3/8" flat washers (W), lock washers (U), and 3/8"-24 x 7/8" hex head cap screws (N). Torque both mounting screws to 20 ft/lbs.

**NOTE**

*The fitting on top of the bellows points inward (fig. 7).*

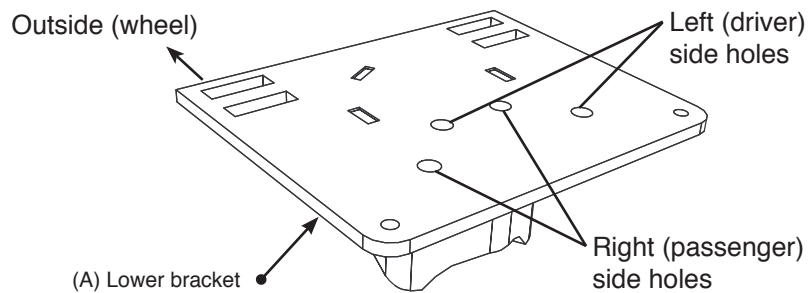

fig. 5

5. Insert two 3/8"-16 x 1.25" carriage bolts (P) up through the bottom of the upper brackets (fig. 7), through the two square holes that are on the corresponding side. Also, insert one 3/8"-16 x 2.5" carriage bolt (M) through the remaining hole. The head of this carriage bolt will be hidden once mounted to the bellows.
6. Set the driver side (left) upper bracket onto the driver side bellows assembly previously assembled, using the holes in the upper bracket designated (fig. 6), and attach to the bellows with two 3/8" flat washers (W), lock washers (U), and 3/8"-24 x 7/8" hex head cap screws (N). Torque both mounting screws to 20 ft/lbs.
7. Repeat the above process for the opposite side assembly (fig. 7).
8. Set the spacer (F) over both long carriage bolts (fig. 7).

**NOTE**

*The hole in the flat spacer (F) is offset. Install the spacer so that the wide portion faces the outside of the vehicle (fig. 7).*

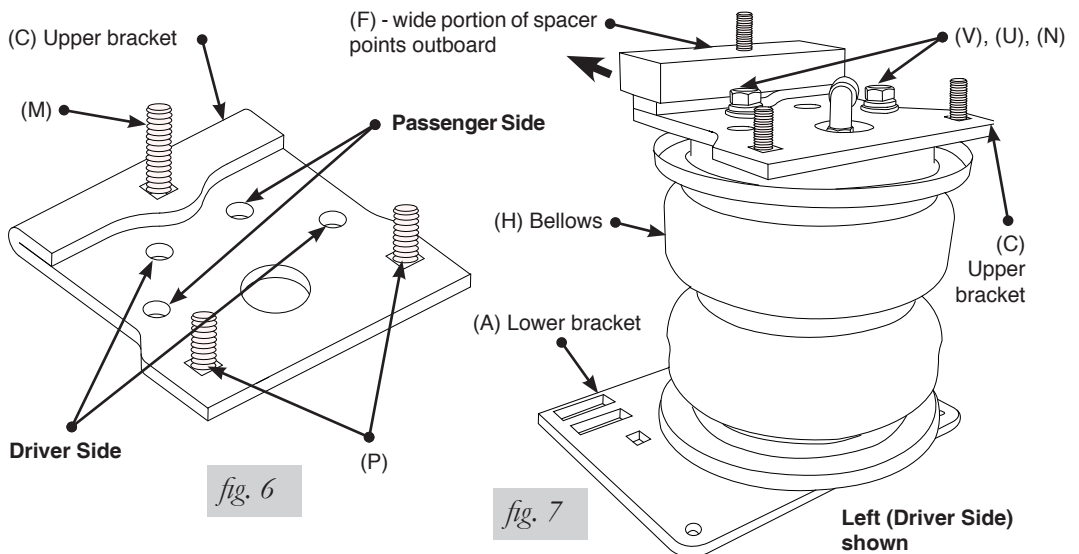

fig. 6

fig. 7

## ATTACHING THE ASSEMBLIES TO THE FRAME

1. If not done so yet, drop the axle or raise the frame up to make room for the assemblies to be put into position.
2. Set the left (driver side) assembly onto the axle (fig. 1). Raise the axle just enough to insert the long carriage bolt (M) (that is installed in the upper bracket) through the existing jounce bumper hole in the bottom of the frame. At the same time, line up the upper brace previously installed onto the remaining two carriage bolts (P) in the upper bracket. Do this just enough for the carriage bolt to hold the assembly into position on the axle (fig. 1).
3. Set the right (passenger side) assembly into position on the axle the same way the left side was positioned (fig. 1).
4. Raise the axle or lower the frame down so that the thick spacer (F) on the upper bracket is parallel to, and contacts the frame (on both sides).
5. Install the 3/8" Flat Washer (W) and a 3/8"-16 Nyloc nut (V) on the carriage bolt (M) that went through the existing jounce bumper hole and tighten securely on both sides (fig. 1).

### CAUTION

BE SURE NOT TO PINCH THE PREVIOUSLY MOVED WIRING OR LINES INSIDE THE LEFT FRAME RAIL.

6. Cap the brace/upper bracket carriage bolts (P) with a 3/8" flat washer (W) and 3/8" nyloc nut (V) and tighten both securely on both sides.
7. With the spacers (F) on the upper brackets tight to the bottom of the frame and the braces tight to the upper bracket, tighten the 1/2 or 3/4" hardware previously installed, that hold the braces to the frame. Tighten both sides securely.
8. If so equipped with the emissions line previously loosened from the frame, insert the line holder post into the L-bracket (J) attached to the back leg of the upper left brace (B) (fig. 8). It may be necessary to move the line holder post forward or back on the lines to line up correctly with the L-bracket hole. Reattach any line holders removed forward or behind the axle, if possible, that were removed to aid in positioning the upper bracket.

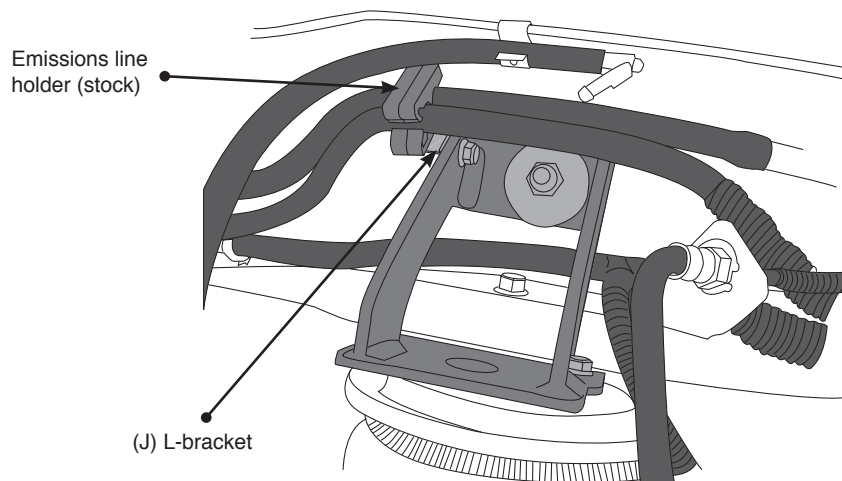

fig. 8

## LOWER BRACKET ATTACHMENT

### CAUTION

ATTACHING THE LOWER BRACKET WILL DEPEND ON THE MODEL TRUCK YOU HAVE. SEE FIGURE 10 TO DETERMINE WHICH HOLES TO USE FOR INSERTING THE CARRIAGE BOLTS.

1. Insert a 3/8-16 x 5.5 hex head bolt (K) and flat washer (W) into one of the two bottom holes of the locating bracket (I) (fig. 9).

### NOTE

*Use the hole that is closest to the leaf spring.*



- 2a. If you are installing this kit on a single rear wheel (SRW) vehicle, use position 2 to insert the long 3/8-16 x 10" carriage bolt (Q) through the top of the locating bracket and lower bracket (fig. 9).
- 2b. If you are installing this kit on a dual rear wheel (DRW) vehicle, use position 1 to insert the long 3/8-16 x 10" carriage bolt (Q) through the top of the locating bracket and lower bracket (fig. 9).
3. Attach the locating bracket (I) to the lower bracket with a 3/8-16 x 1.25" carriage bolt (P), flat washer (W) and nyloc nut (V) using the remaining slot in the top of the locating bracket. Leave loose at this time.
4. Push the front and back locating brackets against the u-bolts and tighten the short carriage bolts at this time.
5. Using the 3/8-16 x 5.5 hex head bolts (K) and flat washers (W) previously installed on the locating brackets, insert them into the spring clamp bar (E) on the opposite side of the leaf spring assembly (fig. 9). Cap with 3/8" flat washers (W) and nyloc nuts (V). Leave loose at this time.

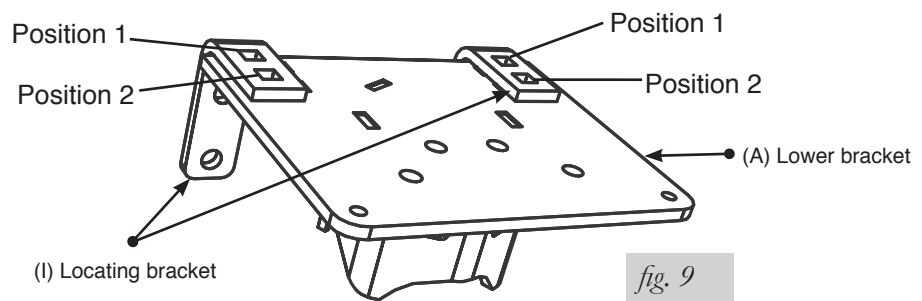

fig. 9

6. Set the axle clamp bar (D) onto the long 3/8-16 x 10" carriage bolts (Q) (fig. 1) and cap with 3/8" flat washers (W) and nyloc nuts (V).

## NOTE

*If you have a sway bar under the axle and the carriage bolt (Q) interferes, invert the carriage bolt.*

7. Carefully draw the side hardware and axle hardware evenly. Torque the spring clamp bar bolts to 10 ft/lbs and the axle clamp bar bolts to 16 ft/lbs. Repeat for opposite side. Trim carriage bolts below nyloc nuts if necessary.

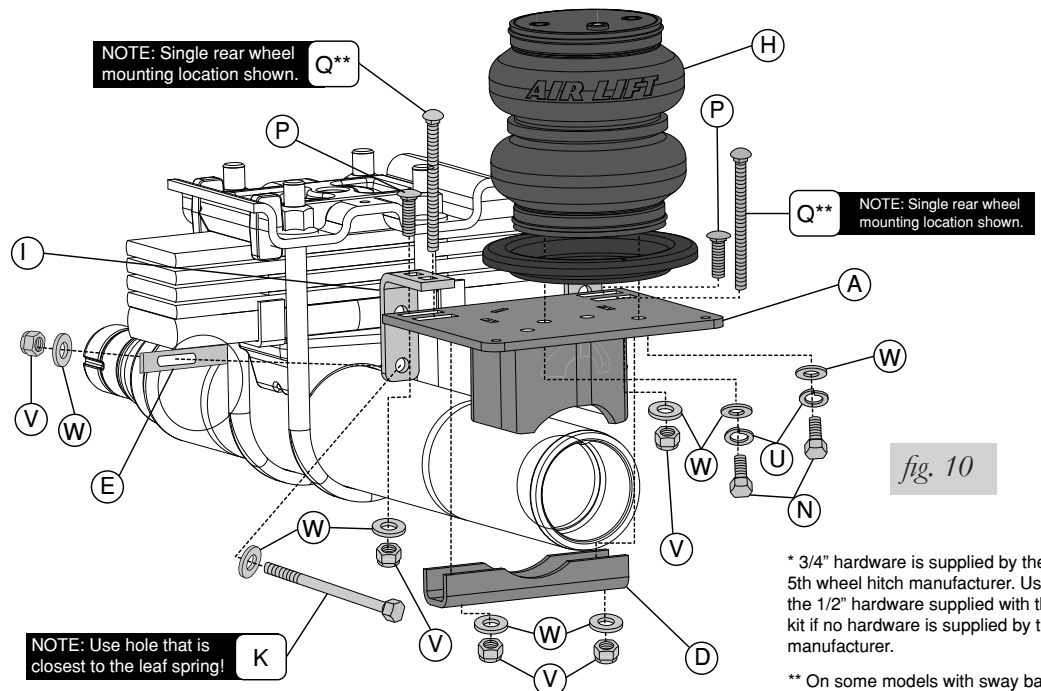

fig. 10

\* 3/4" hardware is supplied by the 5th wheel hitch manufacturer. Use the 1/2" hardware supplied with this kit if no hardware is supplied by the manufacturer.

\*\* On some models with sway bars under the axle, it may be necessary to invert the long carriage bolt.

**NOTE**

For 2WD and 4WD DRW vehicles, in order to install the sway bar and sway bar retaining straps back onto the axle, it will be necessary to slot the retaining straps (fig. 11). Reattach the sway bar once this is done.

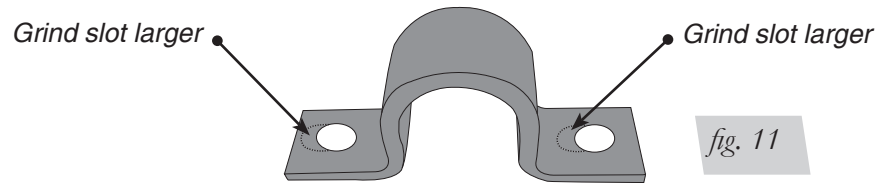
**FINAL STEPS**

1. The emergency brake cable will have to be re-located away from the bellows.

**CAUTION**

FAILURE TO DO SO MAY CAUSE FAILURE TO THE BELLOWS AND VOID THE WARRANTY.

2. Secure the emergency brake cable to the bottom bracket with supplied wire tie using the hole in the corner of the lower bracket (fig. 12).

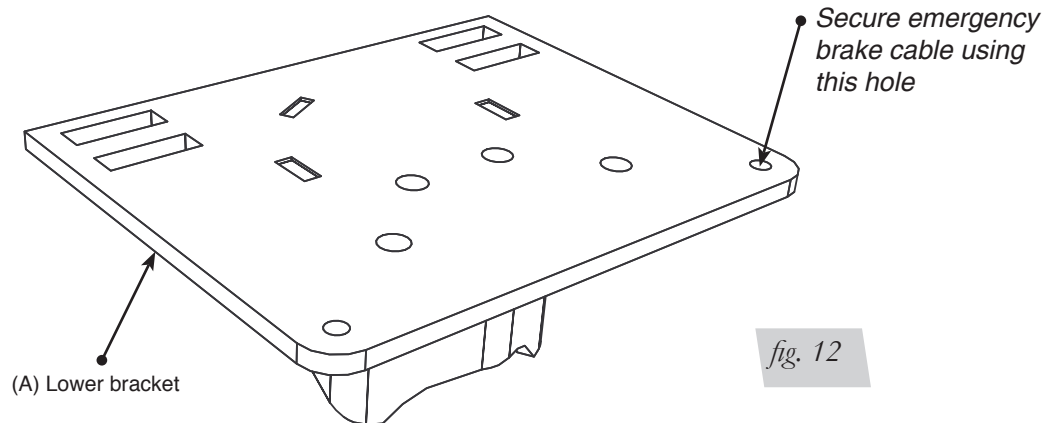

## INSTALLING THE AIR LINES

1. Choose a convenient location for mounting the inflation valves. Popular locations for the inflation valve are:
  - a. The wheel well flanges
  - b. The license plate recess in bumper
  - c. Under the gas cap access door
  - d. Through the license plate

### NOTE

*Whatever the chosen location, make sure there is enough clearance around the inflation valves for an air chuck.*

2. Drill two 5/16" holes to install the inflation valves.
3. Cut the air line assembly in two equal lengths.

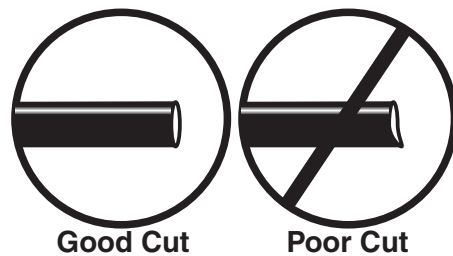

fig. 13

### CAUTION

WHEN CUTTING OR TRIMMING THE AIR LINE, USE A HOSE CUTTER, A RAZOR BLADE, OR A SHARP KNIFE. A CLEAN, SQUARE CUT WILL ENSURE AGAINST LEAKS. DO NOT USE WIRE CUTTERS OR SCISSORS TO CUT THE AIR LINE. THESE TOOLS MAY FLATTEN OR CRIMP THE AIR LINE CAUSING IT TO LEAK AROUND THE O-RING SEAL INSIDE THE ELBOW FITTING (FIG. 13).

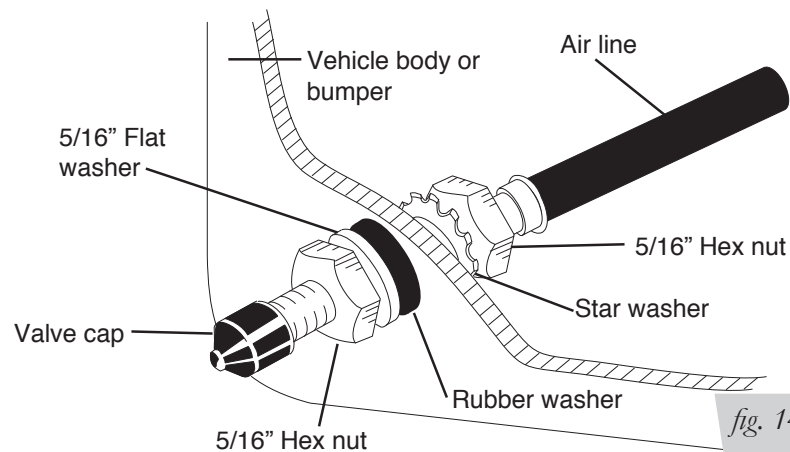

fig. 14

4. Place a 5/16" nut and star washer on the air valve. Leave enough of the inflation valve in front of the nut to extend through the hole and have room for the rubber washer, flat washer, and 5/16" nut and cap. There should be enough valve exposed after installation—approximately 1/2"—to easily apply a pressure gauge or an air chuck (fig. 14).
5. Push the inflation valve through the hole and use the rubber washer, flat washer, and another 5/16" nut to secure it in place. Tighten the nuts to secure the assembly.
6. Route the air line along the frame to the air fitting on the air spring (fig. 15). Keep AT LEAST 6" of clearance between the air line and heat sources, such as the exhaust pipes, muffler, or catalytic converter. Avoid sharp bends and edges. Use the plastic tie straps to secure the air line to fixed, non-moving points along the chassis. Be sure that the tie straps are tight, but do not pinch the air line. Leave at least 2" of slack to allow for any movement that might pull on the air line.

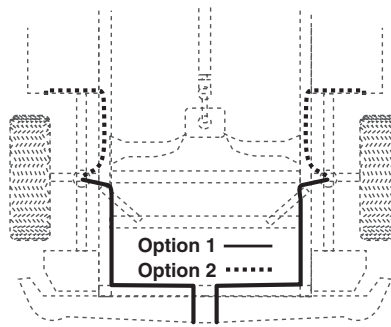

fig. 15

- Cut off the air line, leaving approximately 12" of extra air line. A clean square cut will ensure against leaks. Insert the air line into the air fitting. This is a push-to-connect fitting. Simply push the air line into the 90° swivel fitting until it bottoms out (9/16" of air line should be in the fitting).

## INSTALLING THE HEAT SHIELD

- Bend tabs to provide a 1/2" dead air space between exhaust pipe and heat shield (fig. 16).
- Attach the heat shield to the exhaust pipe using the clamps. Bend the heat shield for maximum clearance to the air spring (fig. 16).

### NOTE

*Some vehicles have large resonators in this area, it will be necessary to double up on the clamps to fit these models (fig. 17).*

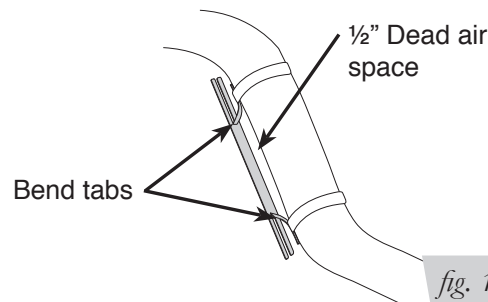

fig. 16

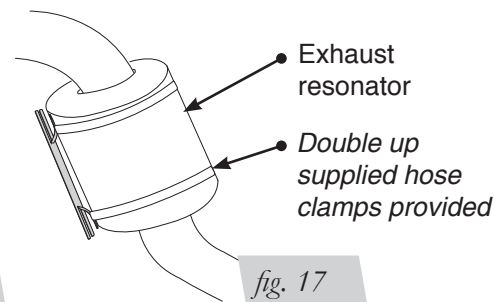

fig. 17

## CHECKING FOR LEAKS

- Inflate the air spring to 30 PSI.
- Spray all connections and the inflation valves with a solution of 1/5 liquid dish soap and 4/5 water. Spot leaks easily by looking for bubbles in the soapy water.
- After the test, deflate the springs to the minimum pressure required to restore the system to normal ride height. Do not deflate to lower than 5 PSI.
- Check the air pressure again after 24 hours. A 2 - 4 PSI loss after initial installation is normal. Retest for leaks if the loss is more than 5 lbs.

## FIXING LEAKS

- If there is a problem with the swivel fitting:
  - Check the air line connection by deflating the spring and removing the line by pulling the collar against the fitting and pulling firmly on the air line. Trim 1" off the end of the air line. Be sure the cut is clean and square (see fig. 13). Reinsert the air line into the push-to-connect fitting.
  - Check the threaded connection by tightening the swivel fitting another 1/2 turn. If it still leaks, deflate the air spring, remove the fitting, and re-coat the threads with thread sealant. Reinstall by hand tightening as much as possible and then use a wrench for an additional two turns.

# Product Use, Maintenance and Servicing

Minimum Pressure	Maximum Air Pressure
5 PSI	100 PSI
FAILURE TO MAINTAIN CORRECT MINIMUM PRESSURE (OR PRESSURE PROPORTIONAL TO LOAD), BOTTOMING OUT, OVER-EXTENSION OR RUBBING AGAINST ANOTHER COMPONENT WILL VOID THE WARRANTY.	

## MAINTENANCE GUIDELINES

### NOTE

*By following the steps below, vehicle owners will obtain the longest life and best results from their air springs.*

1. Check the air pressure weekly.
2. Always maintain normal ride height. Never inflate beyond 100 PSI.
3. If you develop an air leak in the system, use a soapy water solution (1/5 liquid dish soap and 4/5 water) to check all air line connections and the inflation valve core before deflating and removing the air spring.

### CAUTION

FOR YOUR SAFETY AND TO PREVENT POSSIBLE DAMAGE TO YOUR VEHICLE, DO NOT EXCEED MAXIMUM GROSS VEHICLE WEIGHT RATING (GVWR), AS INDICATED BY THE VEHICLE MANUFACTURER. ALTHOUGH YOUR AIR SPRINGS ARE RATED AT A MAXIMUM INFLATION PRESSURE OF 100 P.S.I., THE AIR PRESSURE ACTUALLY NEEDED IS DEPENDANT ON YOUR LOAD AND GVWR.

4. Loaded vehicles require at least 25 PSI or more. A “loaded vehicle” refers to a vehicle with a heavy bed load, a trailer, or both. As discussed above, never exceed GVWR, regardless of air spring, air pressure, or other load assist. The springs in this kit will support approximately 40 lbs. of load (combined on both springs) for each 1 PSI of pressure. The required air pressure will vary depending on the state of the original suspension. Operating the vehicle below the minimum air spring pressure will void the Air Lift warranty.
5. When increasing load, always adjust the air pressure to maintain the normal ride height. Increase or decrease pressure from the system as necessary to attain normal ride height for optimal ride and handling. Remember that loads carried behind the axle (including tongue loads) require more leveling force (pressure) than those carried directly over the axle.
6. Always add air to springs in small quantities, checking the pressure frequently.
7. Should it become necessary to raise the vehicle by the frame, make sure the system is at minimum pressure (5 PSI) to reduce the tension on the suspension/brake components. Use of on board leveling systems do not require deflation or disconnection.
8. Periodically check the air spring system fasteners for tightness. Also, check the air springs for any signs of rubbing. Realign if necessary.
9. On occasion, give the air springs a hard spray with a garden hose in order to remove mud, sand, gravel or other abrasive debris.

## Troubleshooting Guide

1. Leak test the air line connections, the threaded connection into the air spring, and all fittings in the control system.
2. Inspect the air lines to be sure none are pinched. Tie straps may be too tight. Loosen or replace the strap and replace leaking components.

3. Inspect the air line for holes and cracks. Replace as needed.
4. Look for a kink or fold in the air line. Reroute as needed.

If the preceding steps do not solve the problem, it is possibly caused by a failed air spring — either a factory defect or an operating problem. Please call Air Lift at (800) 248-0892 for assistance.

## Frequently Asked Questions

### Q. Will installing air springs increase the weight ratings of a vehicle?

No. Adding air springs will not change the weight ratings (GAWR, GCWR and/or GVWR) of a vehicle. Exceeding the GVWR is dangerous and voids the Air Lift warranty.

### Q. Is it necessary to keep air in the air springs at all times and how much pressure will they need?

The minimum air pressure should be maintained at all times. The minimum air pressure keeps the air spring in shape, ensuring that it will move throughout its travel without rubbing or wearing on itself.

### Q. Is it necessary to add a compressor system to the air springs?

No. Air pressure can be adjusted with any type of compressor as long as it can produce sufficient pressure to service the springs. Even a bicycle tire pump can be used, but it's a lot of work.

### Q. How long should air springs last?

If the air springs are properly installed and maintained they can last indefinitely.

### Q. Will raising the vehicle on a hoist for service work damage the air springs?

No. The vehicle can be lifted on a hoist for short-term service work such as tire rotation or oil changes. However, if the vehicle will be on the hoist for a prolonged period of time, support the axle with jack stands in order to take the tension off of the air springs.

## Tuning the Air Pressure

Pressure determination comes down to three things — level vehicle, ride comfort, and stability.

### 1. Level vehicle

If the vehicle's headlights are shining into the trees or the vehicle is leaning to one side, then it is not level (fig. 18). Raise the air pressure to correct either of these problems and level the vehicle.

### 2. Ride comfort

If the vehicle has a rough or harsh ride it may be due to either too much pressure or not enough (fig. 19). Try different pressures to determine the best ride comfort.

### 3. Stability

Stability translates into safety and should be the priority, meaning the driver may need to sacrifice a perfectly level and comfortable ride. Stability issues include roll control, bounce, dive during braking and sponginess (fig. 20). Tuning out these problems usually requires an increase in pressure.



Bad headlight aim

*fig. 18*



Rough ride

*fig. 19*

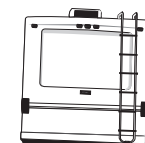

Sway and  
body roll

*fig. 20*

# Guidelines for Adding Air

1. Start with the vehicle level or slightly above.
2. When in doubt, always add air.
3. For motorhomes, start with 50-100 PSI in the rear because it can be safely assumed that it is heavily loaded.
4. If the front of the vehicle dives while braking, increase the pressure in the front air bags, if equipped.
5. If it is ever suspected that the air bags have bottomed out, increase the pressure (fig. 21).
6. Adjust the pressure up and down to find the best ride.
7. If the vehicle rocks and rolls, adjust the air pressure to reduce movement.
8. It may be necessary to maintain different pressures on each side of the vehicle. Loads such as water, fuel, and appliances will cause the vehicle to be heavier on one side (fig. 22). As much as a 50 PSI difference is not uncommon.



Bottoming out

*fig. 21*

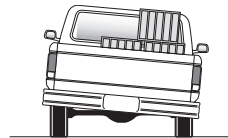

Unlevel

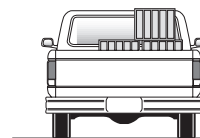

Level

*fig. 22*