

LoadLIFTER **5000** by AIR LIFT®

**Kit 57290,
57295, 57297**
Dodge 2500/3500
2WD & 4WD

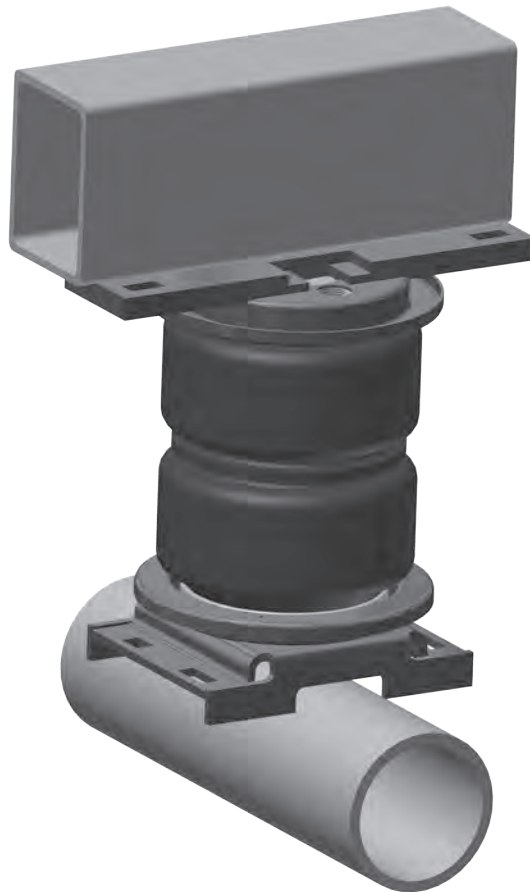

INSTALLATION GUIDE

For maximum effectiveness and safety, please read these instructions completely before proceeding with installation.

Failure to read these instructions can result in an incorrect installation.

Introduction

The purpose of this publication is to assist with the installation, maintenance and troubleshooting of the LoadLifter 5000 air spring kit. LoadLifter 5000 utilizes sturdy, reinforced, commercial grade single or double, depending on the kit, convolute bellows. The bellows are manufactured like a tire with layers of rubber and cords that control growth. LoadLifter 5000 kits are recommended for most $\frac{3}{4}$ and 1 ton pickups and SUVs with leaf springs and provide up to 5,000 lbs of load leveling support with air adjustability from 5-100 PSI. The kits are also used in motorhome rear kits and some motorhome fronts where leaf springs are used.

It is important to read and understand the entire installation guide before beginning installation or performing any maintenance, service or repair. The information here includes a hardware list, tool list, step-by-step installation information, maintenance tips, safety information and a troubleshooting guide.

IMPORTANT SAFETY NOTICE

The installation of this kit does not alter the Gross Vehicle Weight Rating (GVWR) or payload of the vehicle. Check your vehicle's owner's manual and do not exceed the maximum load listed for your vehicle.

Gross Vehicle Weight Rating: The maximum allowable weight of the fully loaded vehicle (including passengers and cargo). This number — along with other weight limits, as well as tire, rim size and inflation pressure data — is shown on the vehicle's Safety Compliance Certification Label.

Payload: The combined, maximum allowable weight of cargo and passengers that the truck is designed to carry. Payload is GVWR minus the Base Curb Weight.

NOTATION EXPLANATION

Hazard notations appear in various locations in this publication. Information which is highlighted by one of these notations must be observed to help minimize risk of personal injury or possible improper installation which may render the vehicle unsafe. Notes are used to help emphasize areas of procedural importance and provide helpful suggestions. The following definitions explain the use of these notations as they appear throughout this guide.

 **DANGER**

INDICATES IMMEDIATE HAZARDS WHICH WILL RESULT IN SEVERE PERSONAL INJURY OR DEATH.

 **WARNING**

INDICATES HAZARDS OR UNSAFE PRACTICES WHICH COULD RESULT IN SEVERE PERSONAL INJURY OR DEATH.

 **CAUTION**

INDICATES HAZARDS OR UNSAFE PRACTICES WHICH COULD RESULT IN DAMAGE TO THE MACHINE OR MINOR PERSONAL INJURY.

NOTE

Indicates a procedure, practice or hint which is important to highlight.

Installation Diagram

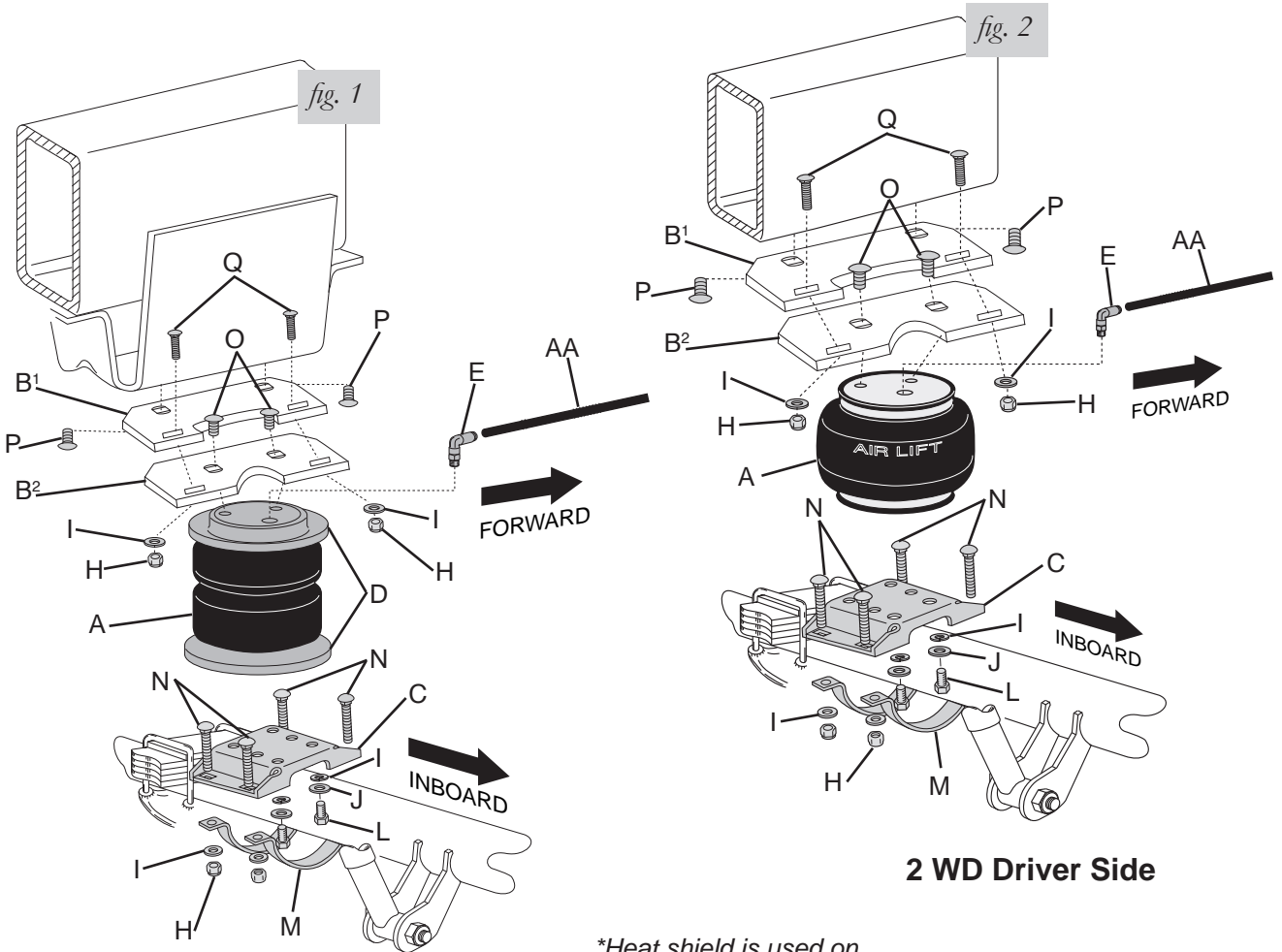

4 WD Driver Side

2 WD Driver Side

**Heat shield is used on the passenger side only.*

HARDWARE LIST

Item	Part #	Description.....Qty	Item	Part #	Description.....Qty
A ¹	58437	2B6 Bellow (57295)..... 2	M	01815	4" Axle strap..... 4
A ²	58491	2B6 Bellow (57290)..... 2	N	17277	3/8"-16 x 3 Carriage bolt..... 8
A ³	58407	1B6 Bellow (57297)..... 2	O	17365	3/8"-24 x 7/8 Button head screw..... 4
B ¹	07149	Frame upper bracket..... 2	P	17366	M10-1.50 x 35 Button head screw..... 4
B ²	07256	Cylinder upper bracket..... 2	Q	17361	3/8"-16 x 1.25 Carriage bolt..... 4
C	03230	Lower bracket..... 2			
D	11951	Roll plates (4WD only)..... 4	AA	20086	Air line assembly..... 1
E	21837	Elbow fitting..... 2	*BB	10466	Tie strap..... 6
*F	09484	Thermal sleeve..... 1	*CC	21230	Valve caps..... 2
*G	10613	Heat shield..... 1	*DD	18405	5/16" Flat washer..... 2
H	18436	3/8" Nyloc nut..... 12	*EE	21234	Rubber washer..... 2
I	18444	3/8" Flat washer..... 12	*FF	18411	Small star washer..... 2
J	18427	3/8" Lock washer..... 4	*GG	21233	5/16" Hex nut..... 4
*K	10741	Clamp #48-102..... 2			
L	17203	3/8" x 7/8" Hex head cap screw..... 4			

*Not shown in diagram.

TOOLS LIST

Description.....	Qty	Description.....	Qty
7/16" and 9/16" Open-end or box wrenches.....	2	Standard and metric allen head wrenches	2
Crescent wrench.....	1	Hose cutter, razor blade, or sharp knife	1
Ratchet with 3/8", 9/16", & 1/2" deep well sockets.....	1	Hoist or floor jacks.....	1
3/8" and 5/16" drill bits (very sharp).....	1	Safety stands.....	1
3/8" Nut driver.....	1	Safety glasses.....	1
Heavy duty drill.....	1	Air compressor or compressed air source.....	1
Torque wrench.....	1	Spray bottle with dish soap/water solution	1

Installing the LoadLifter 5000 System

IMPORTANT SYSTEM INFORMATION

The air springs will last much longer if they are not the suspension limiter in either compression or extension. The air spring compresses to 2.8" and extends to 9.1". Regardless of the load, the air pressure should be adjusted so that the normal ride height is maintained at all times. The shock absorber is usually the limiter on extension. If this is not the case, the use of limiting straps should be considered, particularly for off-road vehicles.

CAUTION

A DISTANCE OF 4" OR GREATER MUST BE MAINTAINED BETWEEN THE UPPER AND LOWER BRACKET FOR KIT #57297 (2WD). ADD SUFFICIENT PRESSURE TO MAINTAIN THIS HEIGHT.

Your vehicle may be equipped with a rear brake proportioning valve. Any type of load assist product could affect brake performance. We recommend that you check with your dealer before installing this type of product. If your vehicle DOES NOT have a rear brake proportioning valve or is equipped with an anti-lock type brake system, installation of a load assist product will have NO EFFECT on brake system performance.

DANGER

COMPRESSED AIR CAN CAUSE INJURY AND DAMAGE TO THE VEHICLE AND PARTS IF IT IS NOT HANDLED PROPERLY. FOR YOUR SAFETY, DO NOT TRY TO INFLATE THE AIR SPRINGS UNTIL THEY HAVE BEEN PROPERLY SECURED TO THE VEHICLE.

REMOVING THE JOUNCE BUMPER

1. Raise the vehicle and support the axle with jack stands, setting the jack stands as wide as possible on the axle (fig. 3).
2. **2WD vehicles:** Remove the jounce bumpers from the bottom of the frame.
4WD vehicles: Remove the jounce bumpers from the jounce bumper bracket.

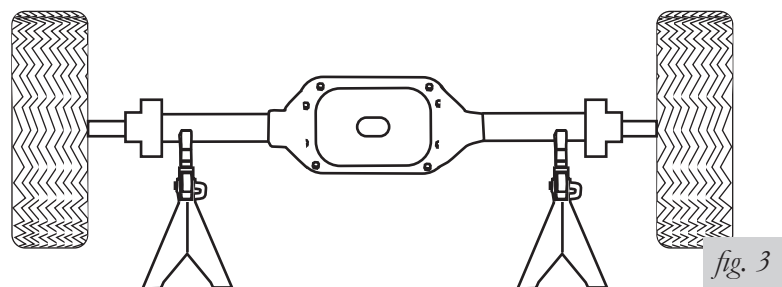

ASSEMBLING THE AIR SPRING

1. Set a roll plate (D) on both ends of the air spring (fig. 4). Four wheel drive models only.

NOTE

The radiused (rounded) edge of the roll plate will be towards the air spring so that the air spring is seated inside both roll plates (fig. 4).

2. Install a 90° swivel air fitting (E) finger tight plus 1½” turns (fig. 4). Use a 7/16” open end wrench. Be careful to tighten on the metal hex nut only. **DO NOT OVERTIGHTEN.** (This fitting is pre-coated with a sealant.)
3. Place the upper bracket (B²) onto the top of the air spring. Attach the upper bracket (B²) to the assembly using 3/8” button head screws (O). Tighten securely (fig. 4).
4. Insert the carriage bolts through the holes in the lower bracket (C) (fig. 4).
5. Place the lower bracket on the air spring in an offset position (fig. 4).

NOTE

The bellows assembly will offset (overhang) the lower bracket. Make sure that the offset is on the air fitting side of the assembly.

6. Using the template provided at the end of the manual, determine the correct holes for mounting the bracket. Use the holes marked by an “A” for bellows mounting.
7. Attach the lower bracket to the assembly using 3/8” flat washer (J), 3/8” lock washers (I) and hex head bolts (L). Tighten securely.

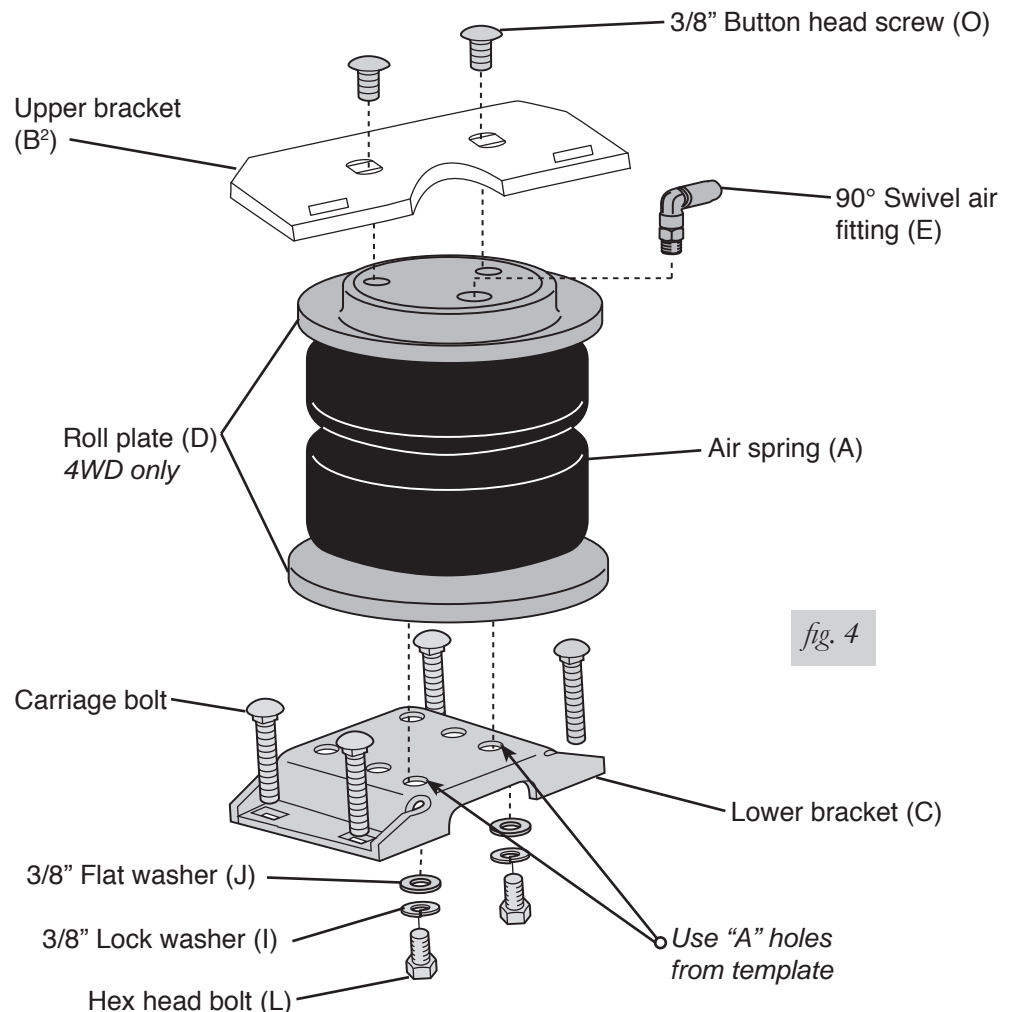
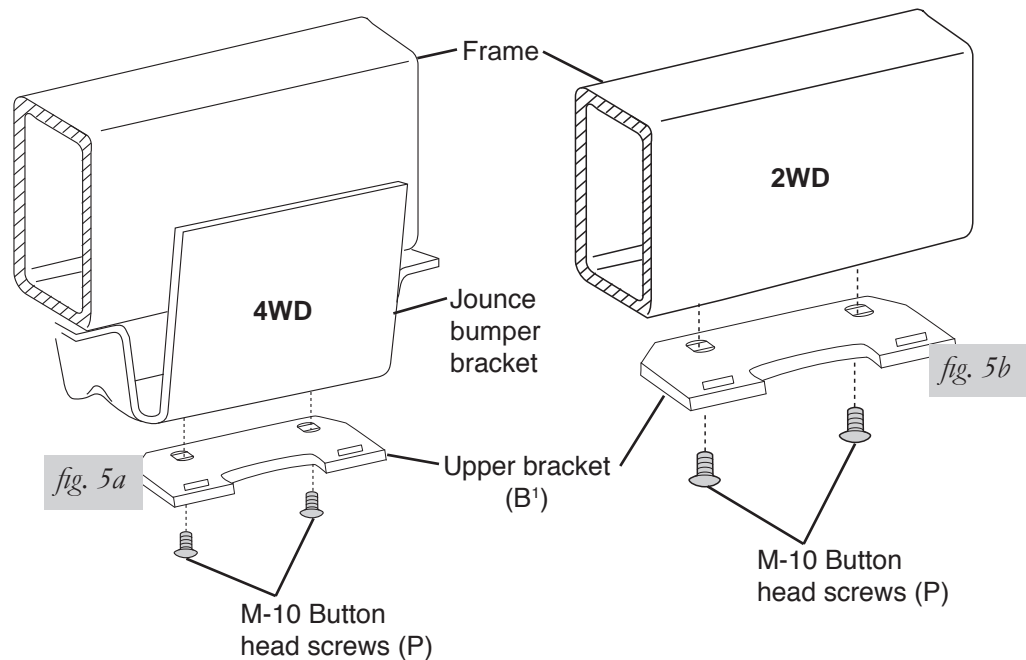

fig. 4

ATTACHING THE FRAME UPPER BRACKET

1. Attach the frame upper brackets, (B¹) to the frame using M-10 button head screws (P). Tighten securely (fig. 5).



ATTACHING THE UPPER BRACKET

1. Set the assembly onto the axle with the 90° swivel air fitting pointing inward towards the center of the truck.

NOTE

If necessary, jack up the chassis to gain clearance to set the assembly into position.

2. Align the slots in the frame upper bracket and bellow upper bracket. Attach the two with the 3/8" carriage bolts (Q), flat washer (I) and nyloc nut (H) (fig. 6).
3. Push the top of the air spring forward or backward and align the upper and lower bracket so they are parallel.

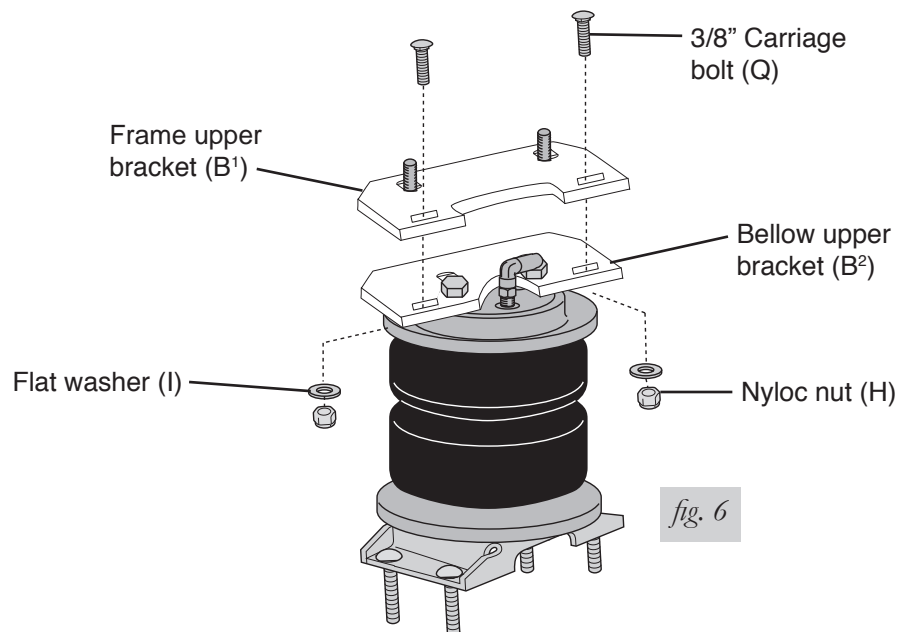

ATTACHING THE LOWER BRACKET

1. Secure the lower bracket to the axle using the axle straps (M), 3/8" flat washers (I), and 3/8" nyloc nuts (H) (fig. 7).

CAUTION

THE BRAKE LINE SITS UNDER THE BRACKET BETWEEN THE CARRIAGE BOLT AND THE AXLE ON THE INSIDE OF THE RIGHT HAND UNIT. THE OUTSIDE CARRIAGE BOLT GOES BETWEEN THE BRAKE LINE AND THE AXLE (FIG. 7).

NOTE

It may be necessary to re-position the brake line on the right and left hand sides to gain clearance.

2. Tighten the lock nuts evenly to 16 ft/lbs. Re-torque after 100 miles.
3. Repeat for the opposite side.

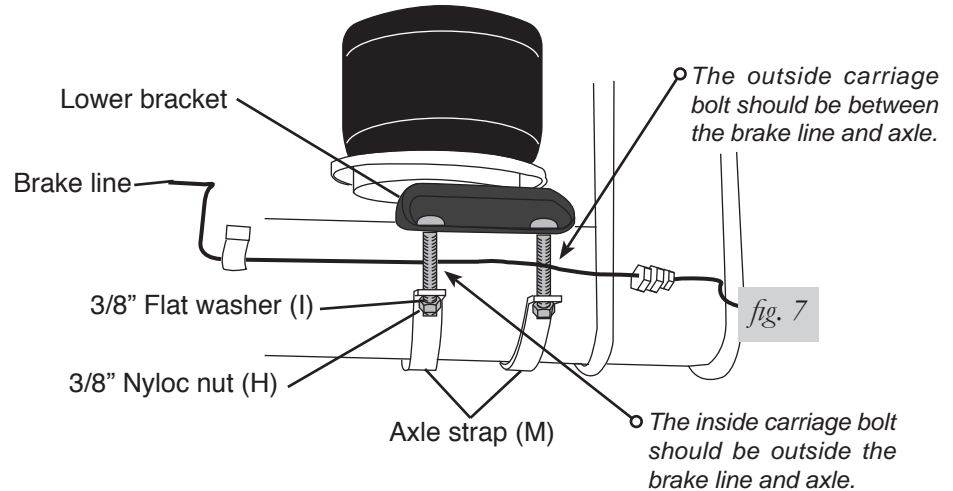

INSTALLING THE HEAT SHIELD

1. Bend the tabs on the heat shield (G) to provide a 1/2" of space between the exhaust pipe and the heat shield (fig. 8).
2. Attach the heat shield to the exhaust pipe using the provided clamps (fig. 9). Bend the heat shield for maximum clearance to the air spring.

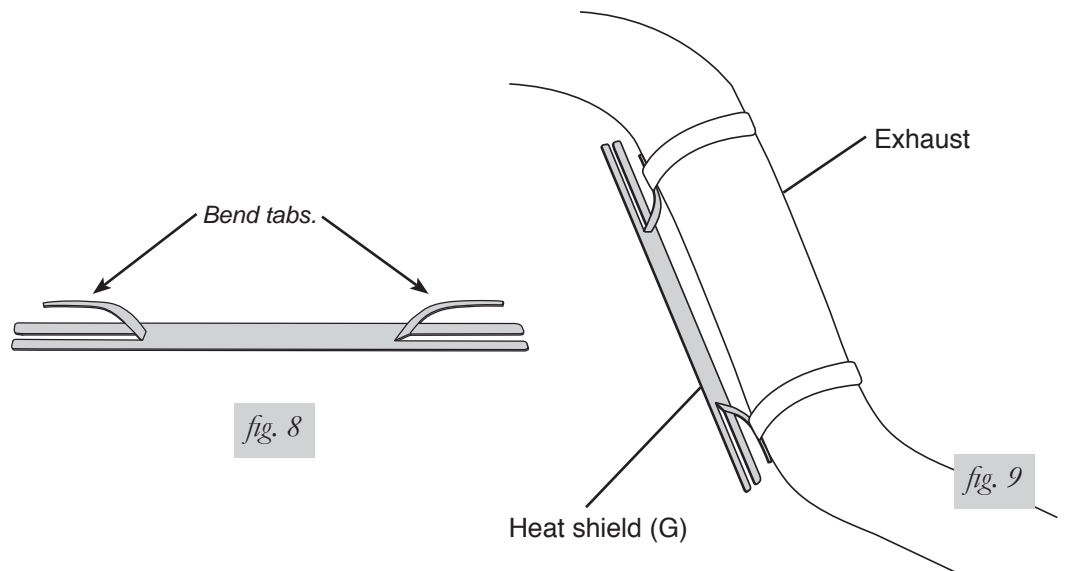

INSTALLING THE AIR LINES

1. Choose a convenient location for mounting the inflation valves. Popular locations for the inflation valve are:
 - a. The wheel well flanges
 - b. The license plate recess in bumper
 - c. Under the gas cap access door
 - d. Through the license plate

NOTE

Whatever the chosen location, make sure there is enough clearance around the inflation valves for an air chuck.

2. Drill two 5/16" holes to install the inflation valves.
3. Cut the air line assembly in two equal lengths.

CAUTION

WHEN CUTTING OR TRIMMING THE AIR LINE, USE A HOSE CUTTER, A RAZOR BLADE, OR A SHARP KNIFE. A CLEAN, SQUARE CUT WILL ENSURE AGAINST LEAKS. DO NOT USE WIRE CUTTERS OR SCISSORS TO CUT THE AIR LINE. THESE TOOLS MAY FLATTEN OR CRIMP THE AIR LINE CAUSING IT TO LEAK AROUND THE O-RING SEAL INSIDE THE ELBOW FITTING (FIG. 10).

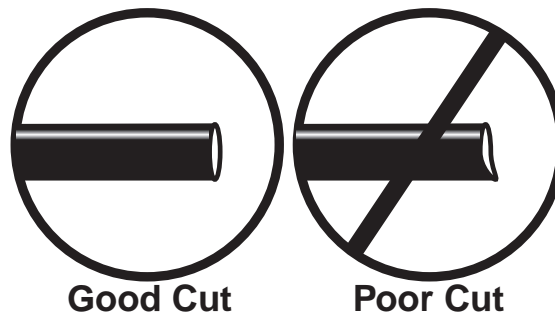

fig. 10

4. Place a 5/16" nut and star washer on the air valve. Leave enough of the inflation valve in front of the nut to extend through the hole and have room for the rubber washer, flat washer, and 5/16" nut and cap. There should be enough valve exposed after installation—approximately 1/2"— to easily apply a pressure gauge or an air chuck (fig. 11).
5. Push the inflation valve through the hole and use the rubber washer, flat washer, and another 5/16" nut to secure it in place. Tighten the nuts to secure the assembly (fig. 11).

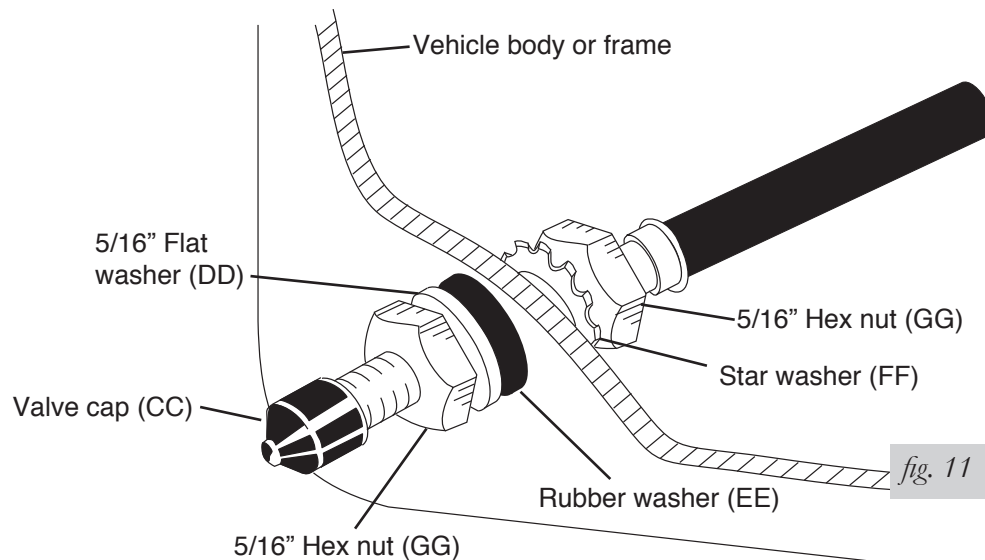

fig. 11

6. Route the air line along the frame to the air fitting on the air spring (fig. 12). Keep AT LEAST 6" of clearance between the air line and heat sources, such as the exhaust pipes, muffler, or catalytic converter. Avoid sharp bends and edges. Use the plastic tie straps to secure the air line to fixed, non-moving points along the chassis. Be sure that the tie straps are tight, but do not pinch the air line. Leave at least 2" of slack to allow for any movement that might pull on the air line.

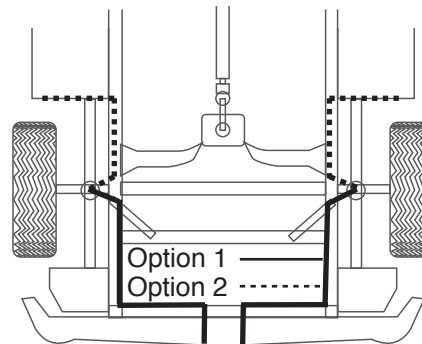

fig. 12

7. Cut off the air line, leaving approximately 12" of extra air line. A clean square cut will ensure against leaks (see fig. 10). Insert the air line into the air fitting. This is a push-to-connect fitting. Simply push the air line into the 90° swivel fitting until it bottoms out (9/16" of air line should be in the fitting).
8. Install the minimum/maximum air pressure decal in a highly visible location. We suggest placing the decal on the driver-side window, just above the door handle.

CHECKING FOR LEAKS

1. Inflate the air spring to 30 PSI.
2. Spray all connections and the inflation valves with a solution of 1/5 liquid dish soap and 4/5 water. Spot leaks easily by looking for bubbles in the soapy water.
3. After the test, deflate the springs to the minimum pressure required to restore the system to normal ride height. Do not deflate to lower than 10 PSI.
4. Check the air pressure again after 24 hours. A 2 - 4 PSI loss after initial installation is normal. Retest for leaks if the loss is more than 5 lbs.

FIXING LEAKS

1. If there is a problem with the swivel fitting:
 - a. Check the air line connection by deflating the spring and removing the line by pulling the collar against the fitting and pulling firmly on the air line. Trim 1" off the end of the air line. Be sure the cut is clean and square (see fig. 10). Reinsert the air line into the push-to-connect fitting.
 - b. Check the threaded connection by tightening the swivel fitting another ½ turn. If it still leaks, deflate the air spring, remove the fitting, and re-coat the threads with thread sealant. Reinstall by hand tightening as much as possible and then use a wrench for an additional two turns.
2. If there is a problem with the inflation valve:
 - a. Check the valve core by tightening it with a valve core tool.
 - b. Check the air line by removing the air line from the barbed type fitting. Cut the air line off a few inches in front of the fitting and use a pair of pliers or vice grips to pull/twist the air line off of the fitting.



CAUTION

DO NOT CUT OFF THE AIR LINE COMPLETELY AS THIS WILL USUALLY NICK THE BARB AND RENDER THE FITTING USELESS.

Troubleshooting Guide

Problems maintaining air pressure, without an on-board compressor.

1. Leak test the air line connections and threaded connection of the elbow into the air spring. See "Fixing Leaks" on page 9 to repair.
2. Leak test the inflation valve for leaks at the air line connection or dirt debris in the valve core. See "Fixing Leaks" on page 9 to repair.
3. Inspect air lines to be sure no line is pinched. Tie straps may be too tight. Loosen or replace the strap. Replace leaking components.
4. Inspect the air line for holes and cracks. Replace as needed.
5. Check for a kink or fold in the air line. Reroute as needed.

Maintenance and Operations

Minimum Air Pressure	Maximum Air Pressure
5 PSI	100 PSI
FAILURE TO MAINTAIN CORRECT MINIMUM PRESSURE (OR PRESSURE PROPORTIONAL TO LOAD), BOTTOMING OUT, OVER-EXTENSION OR RUBBING AGAINST ANOTHER COMPONENT WILL VOID THE WARRANTY.	

MAINTENANCE GUIDELINES

NOTE

By following the steps below, vehicle owners will obtain the longest life and best results from their air springs.

1. Check the air pressure weekly.
2. Always maintain normal ride height. Never inflate beyond 100 PSI.
3. If you develop an air leak in the system, use a soapy water solution (1/5 liquid dish soap and 4/5 water) to check all air line connections and the inflation valve core before deflating and removing the air spring.

CAUTION

FOR YOUR SAFETY AND TO PREVENT POSSIBLE DAMAGE TO YOUR VEHICLE, DO NOT EXCEED MAXIMUM GROSS VEHICLE WEIGHT RATING (GVWR), AS INDICATED BY THE VEHICLE MANUFACTURER. ALTHOUGH YOUR AIR SPRINGS ARE RATED AT A MAXIMUM INFLATION PRESSURE OF 100 PSI, THE AIR PRESSURE ACTUALLY NEEDED IS DEPENDANT ON YOUR LOAD AND GVWR.

4. Loaded vehicles require at least 25 PSI or more. A "loaded vehicle" refers to a vehicle with a heavy bed load, a trailer, or both. As discussed above, never exceed GVWR, regardless of air spring, air pressure, or other load assist. The springs in this kit will support approximately 40 lbs. of load (combined on both springs) for each 1 PSI of pressure. The following chart can be used as a guideline for operating air pressure:

Load	Air Pressure
1000 lbs	25-35 PSI
2000 lbs	45-55 PSI
3000 lbs	70-80 PSI
4000 lbs	90-100 PSI

The previous chart is a general guideline only. Use enough pressure to level the vehicle to normal ride height recorded on page 11 of this manual. The required air pressure will vary depending on the state of the original suspension. Operating the vehicle below the minimum air spring pressure will void the Air Lift warranty.

5. When increasing load, always adjust the air pressure to maintain the normal ride height. Increase or decrease pressure from the system as necessary to attain normal ride height for optimal ride and handling. Remember that loads carried behind the axle (including tongue loads) require more leveling force (pressure) than those carried directly over the axle.
6. Always add air to springs in small quantities, checking the pressure frequently. Sleeves require less air volume than a tire and inflate quickly.
7. Should it become necessary to raise the vehicle by the frame, make sure the system is at minimum pressure (5 PSI) to reduce the tension on the suspension/brake components. Use of on board leveling systems do not require deflation or disconnection.
8. Periodically check the air spring system fasteners for tightness. Also, check the air springs for any signs of rubbing. Realign if necessary.
9. On occasion, give the air springs a hard spray with a garden hose in order to remove mud, sand, gravel or other abrasive debris.

GUIDELINES FOR ADDING AIR

1. Start with the vehicle level or slightly above.
2. When in doubt, always add air.
3. For motorhomes, start with 50-100 PSI in the rear because it can be safely assumed that it is heavily loaded.
4. If the front of the vehicle dives while braking, increase the pressure in the front air bags, if equipped.
5. If it is ever suspected that the air bags have bottomed out, increase the pressure (fig. 16).
6. Adjust the pressure up and down to find the best ride.
7. If the vehicle rocks and rolls, adjust the air pressure to reduce movement.
8. It may be necessary to maintain different pressures on each side of the vehicle. Loads such as water, fuel, and appliances will cause the vehicle to be heavier on one side (fig. 17). As much as a 50 PSI difference is not uncommon.



Bottoming out

fig. 16

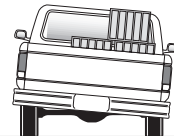

Unlevel

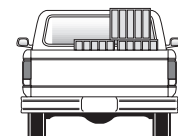

Level

fig. 17

Lower bracket
mounting template.
See "Assembling the
Air Spring," pg. 5.

