

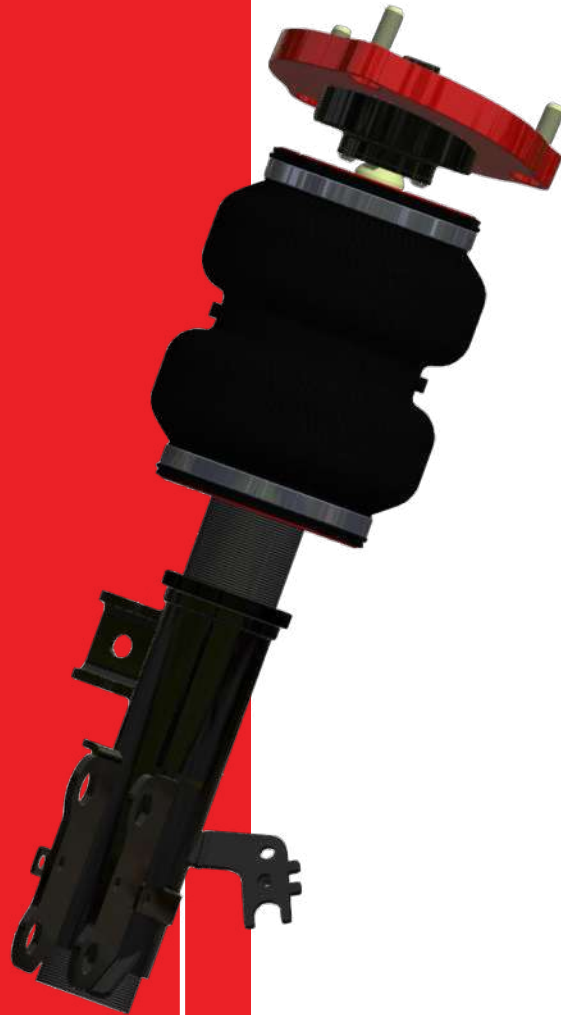

Kits 78586/78585

Toyota Camry XV70 XSE/
SE/XLE/LE

Front Application



INSTALLATION GUIDE

For maximum effectiveness and safety, please read these instructions completely before proceeding with installation.

Failure to read these instructions can result in an incorrect installation.

A. Introduction

Air Lift Performance thanks you for purchasing the most complete, fully engineered high-performance air suspension made for the Toyota Camry XV70 (XSE/SE/XLE/LE). Read these installation instructions to correctly and safely set up the vehicle for a #lifeonair.

Air Lift assumes that the installer has the mechanical knowledge and ability to work on vehicle suspension systems and has basic tools necessary to complete a suspension replacement project. Special tools needed to complete the installation are noted on the *Installation Diagram* page.

Air Lift reserves the right to make changes and improvements to its products and publications at any time.

An Air Lift Performance air management system is highly recommended for this product.

NOTATION EXPLANATION

Hazard notations appear in various locations in this publication. Information which is highlighted by one of these notations must be observed to help minimize risk of personal injury or possible improper installation which may render the vehicle unsafe. Notes are used to help emphasize areas of procedural importance and provide helpful suggestions. The following definitions explain the use of these notations as they appear throughout this guide.

 **DANGER**

INDICATES IMMEDIATE HAZARDS WHICH WILL RESULT IN SEVERE PERSONAL INJURY OR DEATH.

 **WARNING**

INDICATES HAZARDS OR UNSAFE PRACTICES WHICH COULD RESULT IN SEVERE PERSONAL INJURY OR DEATH.

 **CAUTION**

INDICATES HAZARDS OR UNSAFE PRACTICES WHICH COULD RESULT IN DAMAGE TO THE VEHICLE OR MINOR PERSONAL INJURY.

NOTE

Indicates a procedure, practice or hint which is important to highlight.

B. Important Safety Notices

 **WARNING**

DO NOT INFLATE AIR SPRINGS WHILE OFF OF THE VEHICLE. DAMAGE TO ASSEMBLY MAY RESULT AND VOID WARRANTY.

 **CAUTION**

DO NOT WELD TO OR MODIFY PERFORMANCE STRUTS/SHOCKS IN ANY WAY. DAMAGE TO UNIT MAY OCCUR AND WILL VOID WARRANTY.

 **WARNING**

AFTER INSTALLATION, ENSURE ALL ORIGINAL EQUIPMENT VEHICLE SAFETY FEATURES ARE PROPERLY CALIBRATED BY A QUALIFIED TECHNICIAN. CHANGING VEHICLE HEIGHT MAY AFFECT FUNCTIONING OF SAFETY SENSORS AND CAMERAS.

C. Installation Diagram

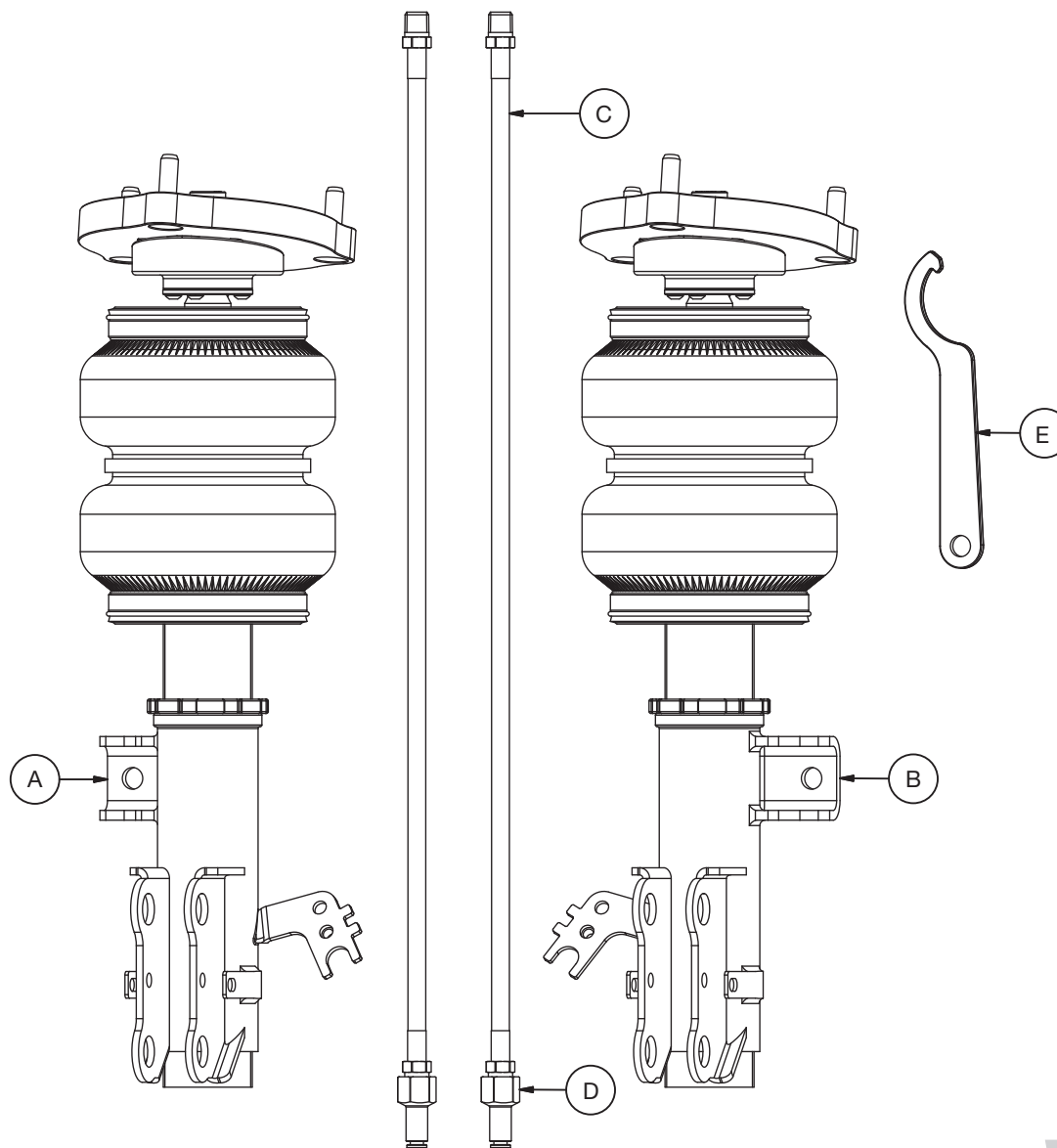

fig. C.1

HARDWARE LIST

Item	Part #	Description	Qty
A	35458	Strut, right front (SE)	1
A*	35456	Strut, right front (LE)	1
B	35459	Strut, left front (SE)	1
B*	35457	Strut, left front (LE)	1
C	20997	Leader line, 1/4"	2
D	21810	1/4" FNPT x 1/4" PTC Fitting	2
E	11289	M50 Spanner	1

* Not shown in the Installation Diagram (Fig. C.1)

D. Installing the Air Suspension

NOTE

See "Important Safety Notices" on page 2.

CAUTION

RAISE THE REAR OF THE VEHICLE WITH A JACK AT THE APPROVED LIFTING POINTS AND USE SAFETY STANDS TO SUPPORT THE VEHICLE.

REMOVING THE STOCK SUSPENSION

1. Raise vehicle and support suspension with safety stands (Fig. D.1). Remove the wheel (Fig. D.2).



fig. D.1



fig. D.2

2. Unbolt brake hose/ABS sensor wire from strut (Figs. D.3 & D.4). Remove ABS sensor wire clip from opposite side of strut (Figs. D.5 & D.6). Retain bolts and clips for reinstallation.



fig. D.3



fig. D.4



fig. D.5



fig. D.6

3. Unbolt sway bar end link from strut tab (Figs. D.7 & D.8).

*fig. D.7**fig. D.8*

4. Remove lower strut mount bolts and separate lower strut mount from steering knuckle (Figs. D.9-D.11).

*fig. D.9**fig. D.10**fig. D.11*

5. Remove upper strut mount nuts and remove strut from vehicle (Figs. D.12 & D.13). Retain strut mount nuts for reinstallation.

*fig. D.12**fig. D.13*

INSTALLING AIR LIFT PERFORMANCE SUSPENSION

1. Begin by installing the leader line (C) into the air spring. Tighten the fitting (D) to the leader line (1 3/4 turns beyond hand-tight). Tighten the leader line into the air spring 1 3/4 turns beyond hand-tight (Fig. D.14).

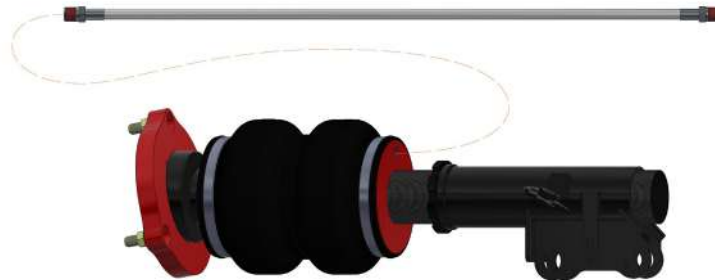
*fig. D.14*

2. Insert the Air Lift Performance upper strut mount into the strut tower (Fig. D.15). Install the previously removed upper mount nuts (Fig. D.16) and torque to 50Nm (37 lb.-ft.). Ensure proper orientation of the lower strut mount to the front knuckle before torquing nuts.

*fig. D.15**fig. D.16*

- Slide the lower strut mount over the steering knuckle and install the lower mount bolts (Figs. D.17 & D.18). Torque the bolts to 290Nm (214 lb.-ft.).

*fig. D.17**fig. D.18*

- Reinstall the sway bar end link on the Air Lift Performance strut (A or B) (Fig. D.19). Torque the sway bar end link nut to 74Nm (55 lb.-ft.).

*fig. D.19*

5. Install the brake hose/ABS sensor wire brackets with the previously removed bolt (Fig. D.20). Torque the bolt to 29Nm (21 lb.-ft.). Insert the ABS sensor wire clip into the retainer on the opposite side of the strut (Fig. D.21).

*fig. D.20**fig. D.21*

6. Reinstall wheels and torque to 103Nm (76 lb.-ft.).

ROUTING THE AIR LINES

1. Fully compress the suspension using a jack. With the suspension compressed, review the best routing for the air line that is clear of all suspension and steering components.
2. Routing should allow for the suspension to extend and steer without kinking, pulling the line tight or rubbing on other components. Following the brake line routing is often a good place to start. Check clearances to all other components.

WARNING

AFTER INSTALLATION, ENSURE ALL ORIGINAL EQUIPMENT VEHICLE SAFETY FEATURES ARE PROPERLY CALIBRATED BY A QUALIFIED TECHNICIAN. CHANGING VEHICLE HEIGHT MAY AFFECT FUNCTIONING OF SAFETY SENSORS AND CAMERAS.

E. Before Operating

SETTING THE RIDE HEIGHT

1. Refer to the User Guide supplied with this kit to set up the suspension.

Torque Specifications		
Location	Nm	lb.-ft.
Upper strut mount nuts	50	37
Lower strut mount bolts	290	214
Sway bar end link nut	74	55
Brake hose/ABS wire bracket	29	21
Wheel lugnuts	103	76

Table 1

Suggested Driving Air Pressure	Maximum Air Pressure
40-50 PSI (2.8-3.4BAR)	125 PSI (8.6BAR)
<p>FAILURE TO MAINTAIN ADEQUATE MINIMUM PRESSURE (OR PRESSURE PROPORTIONAL TO LOAD) MAY RESULT IN EXCESSIVE BOTTOMING OUT AND WILL VOID THE WARRANTY.</p>	

Table 2

CHECK FOR BINDING



MAKE SURE THE FRONT WHEELS ARE STRAIGHT WHEN DEFLATING AND REINFLATING AIR SPRINGS.

1. Inflate and deflate the system (do not exceed 125 PSI [8.6BAR]) to check for clearance or binding issues. With the air springs deflated, check clearances on everything so as not to pinch brake lines, vent tubes, etc. Clear lines if necessary.
2. Inflate the air springs to 75-90 PSI (5.2-6.2BAR) and check all connections for leaks.

INSTALLATION CHECKLIST

- Clearance** — Inflate the air springs to 75-90 PSI (5.2-6.2BAR) and make sure there is at least 1/2" (13mm) clearance from anything that might rub against the air spring. This should be checked with the air spring fully inflated and fully deflated.
- Leak** — Inflate the air springs to 75-90 PSI (5.2-6.2BAR) and check all connections for leaks. All leaks must be eliminated before the vehicle is road tested.
- Heat** — Be sure there is sufficient clearance from heat sources, at least 6" (152mm) from air springs and air lines. If a heat shield was included in the kit, install it.
- Fastener** — Recheck all bolts for proper torque.
- Road** — Inflate the air springs to recommended driving pressures (Table 2). Drive the vehicle 10 miles (16km) and recheck for clearance, loose fasteners and air leaks.
- Operating instructions** — If professionally installed, the installer should review the operating instructions with the owner. Be sure to provide the owner with all paperwork that came with the kit.

DAMPING ADJUSTMENT

1. The dampers in this kit have 30 settings, or “clicks,” of adjustable compression and rebound damping characteristics. Damping is changed through the damper rod using the supplied adjuster (Figs. E.1 & E.2) or a 3mm hex key (not included).
2. Turn the adjuster clockwise (H) and the damping settings are hardened, reducing oscillations and body motion. Turn the adjuster counterclockwise (S) and the damping is softened.
3. Each damper in this kit is preset to “-20 clicks.” This means that the damper is adjusted 20 clicks away from full stiff, which starts at 0. Counting up from full stiff is the preferred method of keeping track of, or setting, damping. This setting was developed on a 2017 Toyota Camry XLE.

For more information, refer to the User Guide.



fig. E.1



fig. E.2



AIR LIFT
PERFORMANCE®

USER GUIDE

DAMPERS

	Suggested Damper Settings*	Suggested Driving Air Pressure*	Maximum Air Pressure*
FRONT	- ____ Clicks up from full stiff	____ PSI/BAR	____ PSI/BAR
REAR	- ____ Clicks up from full stiff	____ PSI/BAR	____ PSI/BAR

My Settings

Damper settings

FRONT

Street - ____ clicks

Track - ____

Show - ____

Other - ____

REAR

Street - ____ clicks

Track - ____

Show - ____

Other - ____

Air pressure settings

LEFT FRONT

Street ____

Track ____

Show ____

Other ____

LEFT REAR

Street ____

Track ____

Show ____

Other ____

RIGHT FRONT

Street ____

Track ____

Show ____

Other ____

RIGHT REAR

Street ____

Track ____

Show ____

Other ____

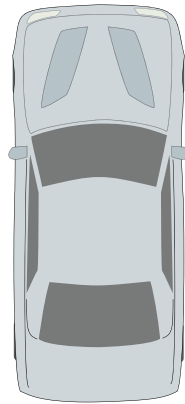

Torque Specifications*			
Location	Nm/Lb.-ft.	Location	Nm/Lb.-ft.
Location	Nm	Lb.-ft.	
Camber plate adjustment bolts	10	7	
Flexible adjuster extension	1 turn beyond hand-tight		
Air fittings/braided air lines	1 3/4 turns beyond hand-tight		
Locking collar	1/2 turn beyond hand-tight		

* Obtain these numbers from the installation guides that came with the kits.

INTRODUCTION

The purpose of this publication is to assist with the use of Air Lift Performance and Slam Series damper systems.

Read the entire user guide before operating. The information includes instructions for proper setup and use of the air spring kit that was designed specifically for your vehicle. Failure to read and follow the instructions in this guide could result in damage to the air springs, dampers or other vehicle components.

NOTATION EXPLANATION

Hazard notations appear in various locations in this publication. Information which is highlighted by one of these notations must be observed to help minimize risk of personal injury or possible improper installation which may render the vehicle unsafe. Notes are used to help emphasize areas of procedural importance and provide helpful suggestions. The following definitions explain the use of these notations as they appear throughout this guide.

**DANGER**

INDICATES IMMEDIATE HAZARDS WHICH WILL RESULT IN SEVERE PERSONAL INJURY OR DEATH.

**WARNING**

INDICATES HAZARDS OR UNSAFE PRACTICES WHICH COULD RESULT IN SEVERE PERSONAL INJURY OR DEATH.

**CAUTION**

INDICATES HAZARDS OR UNSAFE PRACTICES WHICH COULD RESULT IN DAMAGE TO THE MACHINE OR MINOR PERSONAL INJURY.

IMPORTANT SAFETY NOTICES

**WARNING**

BEFORE SERVICING THE VEHICLE, TURN OFF “RISE ON START” AND “PRESET MAINTAIN.” THIS WILL ELIMINATE ANY UNINTENDED SUSPENSION CYCLING IF THE VEHICLE IS TURNED ON FOR ANY REASON.

**WARNING**

AFTER INSTALLATION, ENSURE ALL ORIGINAL EQUIPMENT VEHICLE SAFETY FEATURES ARE PROPERLY CALIBRATED BY A QUALIFIED TECHNICIAN. CHANGING VEHICLE HEIGHT MAY AFFECT FUNCTIONING OF SAFETY SENSORS AND CAMERAS.

SETTING THE RIDE HEIGHT

1. For a better ride, know the vehicle suspension's travel limits. Bumping against the jounce bumpers will contribute to a harsh ride.
2. With the suspension fully compressed, take a measurement from the fender to a chosen reference point – typically the center of the axle. Record this measurement as max compression (MC).
3. Cycle the suspension to max extension (ME) and record the measurement from the fender to the same reference point.

Max Compression



Max Extension



3. Add ME and MC, then divide the total by 2. Set the suspension to this point. This position will give 50% stroke in either direction and is a starting point for ride height.

Formula for Calculating Ride Height

$$(ME+MC) \div 2 = \text{MID STROKE}$$

4. If the ride height is lower than stock, Air Lift Performance recommends loosening all pivot points (bolts, nuts) on any control arm, strut arm or radius rod that contains bushings. Once they have been loosened, re-torque to stock specifications.

ALIGNING THE VEHICLE

The vehicle should be aligned at the suspension height it will most often be driven. This will reduce tire wear and improve performance.

NOTE *It may be necessary to cycle the suspension to loosen the bushings from their mounts. This will help re-orient the bushing at their new positions based on the chosen ride height.*

USING LOWER MOUNT TO ADJUST EXTENDED OR DROP HEIGHT

NOTE *Not all vehicles will have further drop height available.*

These dampers have been preset at the factory to provide maximum drop height while maintaining adequate tire clearance to the air spring. Use the following procedure to gain more extended height (lift), which is the same as reducing drop height or if you want to lower the chassis.

1. Support the vehicle with jack stands or a hoist at approved lifting points.
2. Remove the wheel.
3. Using the supplied spanner wrench, loosen the locking collar.
4. Deflate the air spring to 0 pressure on the corner you are adjusting.
5. Disconnect lower mount from suspension.
6. Spin the lower mount to the desired location.
7. Re-install lower mount to suspension and torque fasteners as specified in the Installation Guide.
8. Tighten the lower locking collar to the lower mount using significant force.

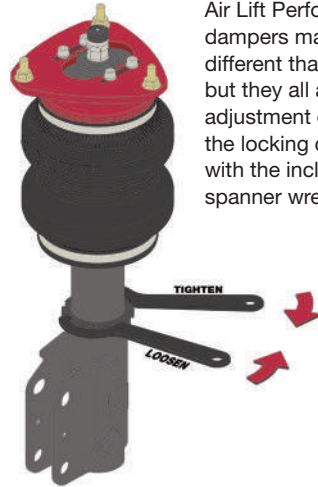

Air Lift Performance dampers may look different than this, but they all allow adjustment of the locking collar with the included spanner wrench.



CAUTION

WHEN ADJUSTING HEIGHT UPWARD, MAKE SURE THAT THE DAMPER BODY ENGAGES ALL THE THREADS OF THE LOWER MOUNT. WHEN ADJUSTING DOWNWARD, MAKE SURE THERE IS ADEQUATE AIR SPRING CLEARANCE TO THE TIRE/WHEEL ASSEMBLY. CLEARANCE MUST BE CHECKED WITH SYSTEM FULLY DEFLATED AS WELL AS FULLY INFLATED TO ENSURE THAT NO RUBBING OCCURS. FAILURE TO MAINTAIN ADEQUATE CLEARANCE CAN RESULT IN AIR SPRING FAILURE AND WILL NOT BE COVERED UNDER WARRANTY.



CAUTION

DO NOT ADJUST HEIGHT BY SPINNING AIR SPRING ON THE DAMPER! DOING SO MAY CAUSE AN AIR LEAK AND COMPROMISE THE ASSEMBLY.

For struts

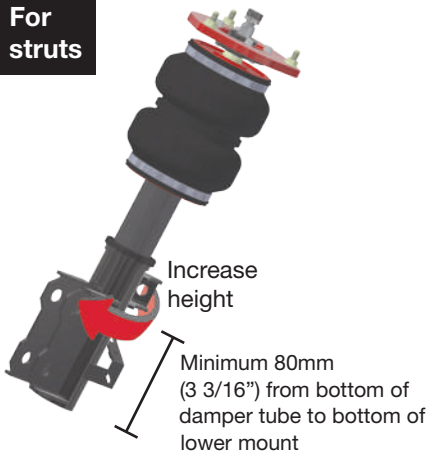

For shocks

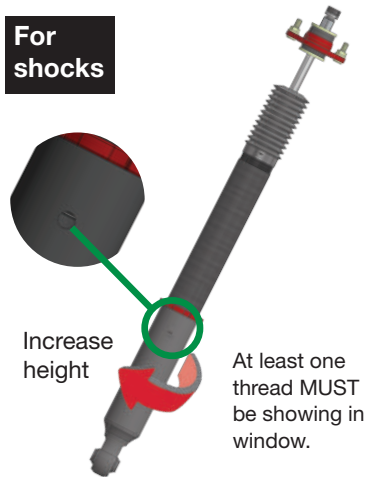

TRIMMING THE FLEXIBLE ADJUSTER

The flexible adjuster extension, which is included in some kits, can be used to extend reach of the damping adjuster knob.

1. Use the supplied 2mm hex key wrench to disassemble the flexible adjuster extension. Determine desired length of adjuster and cut cable to length. Cut sheathing 16-20mm (5/8"-13/16") shorter than the cable length, allowing engagement of the set screws when reassembled. Verify the cable is not protruding beyond the mounting surface of the base.

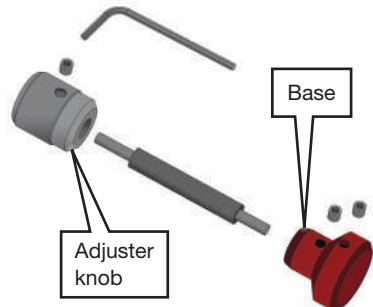

2. Reassemble the adjuster. Tighten the set screws one turn beyond hand tight.

DAMPING ADJUSTMENT

Suspension damping is a matter of compromise. Setting it too stiff will make the ride feel jarring. In addition, if the suspension is too stiff, the tires will lose contact with the road, reducing control and power delivery. On the other hand, if the suspension is too soft, the car can experience floatiness and excessive bouncing. The sweet spot lies somewhere in the middle. Air Lift dampers have a range of adjustment, which allows the driver to tune the ride and handling to his or her preferences.

Air Lift recommends damper and air pressure settings for every vehicle kit, but it is impossible to consider every situation. For example, even though most Air Lift kits replace the dampers and springs, vehicles with sport-tuned suspensions might have stiffer bushings, larger anti-roll bars, bigger wheels, wider tires, etc. These settings may need to be adjusted to different vehicles and driving characteristics.

1. Air Lift Performance dampers* have 30 settings, or “clicks,” of adjustable compression and rebound damping characteristics. Damping is changed through the damper rod using the supplied adjuster, a 3mm hex key (not included) or a damper adjustment wheel.

NOTE *Air Lift Performance dampers use a variety of types of damping adjusters. Here are some examples.*



2. Turn the adjuster clockwise (H) and the damping settings are hardened, reducing oscillations and body motion. Turn the adjuster counterclockwise (S) and the damping is softened.
3. On inverted dampers, the damping adjuster is on the bottom. Turn the adjuster counterclockwise to harden the damping on this type of damper.



4. To adjust the dampers, start at full stiff, which is 0. Count up to keep track of, or set, the damping.

* Air Lift Slam Series kits do not have adjustable damping.

ADJUSTABLE CAMBER PLATES

Camber on many Air Lift Performance dampers* can be adjusted with four bolts on top of the camber plate. These bolts come preset from the factory but can be used to change the vehicle stance or impact vehicle handling.



The camber plates have multiple sets of holes to allow for maximum adjustability. Use the outer holes to achieve maximum negative camber. The camber plates must always be secured with four bolts.

Before making any changes to the camber, take photos of the camber plates to establish a starting point. That will make it easier to go back if necessary.

Demonstrating Camber

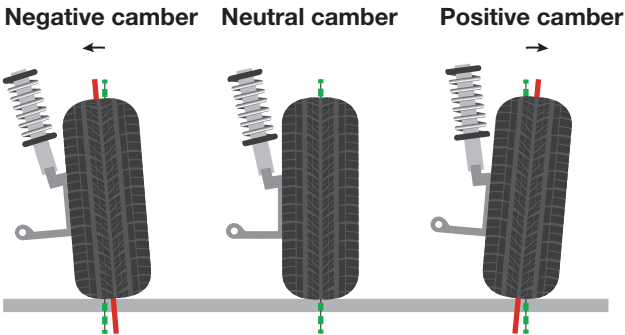

Raise the vehicle on a hoist or with a jack — supported by safety stands, of course — and loosen the 4 small bolts on top of the struts with a 5mm hex wrench.

With the camber bolts loose, push the top of the strut toward the center of the car to increase negative camber. Pull it out from the vehicle to increase positive camber. Don't be afraid to put some muscle into it.

Once the camber is set, torque the 4 bolts to 10Nm (7 lb.-ft.).

* Some Air Lift kits do not have adjustable camber plates.

CHECK FOR PINCHING OR BINDING

Whenever changes are made to the suspension setup, it is important to check for pinching and binding.

Inflate and deflate the system (do not exceed the maximum air pressure for the air springs in these kits) to check for clearance or binding issues. With the air springs deflated, check clearances on everything so as not to pinch brake lines, vent tubes, etc. Clear lines if necessary.

USING THE SYSTEM

1. Always check the air pressure before driving.
2. Regardless of load, air pressure should be adjusted to maintain adequate ride height at all times while driving.



WARNING

BEFORE SERVICING THE VEHICLE, MAKE SURE TO TURN OFF “RISE ON START” AND “PRESET MAINTAIN.” THIS WILL ELIMINATE ANY UNINTENDED SUSPENSION CYCLING IF THE VEHICLE IS TURNED ON.

TUNING THE AIR PRESSURE FOR DAMPER ADJUSTMENT

Pressure determination comes down to three things — level vehicle, ride comfort and stability.

1. Level vehicle

Depending on load, it is possible one side will need more pressure than the other to level the vehicle.

2. Ride comfort

If the vehicle has a harsh ride, it may be due to either too much pressure or not enough causing frequent bottoming out. Also, riding the vehicle at the top, or close to the top of the available stroke will cause an uncomfortable ride due to a lack of rebound travel (See “Setting the Ride Height,” page 5). This situation should be avoided for driving any significant distance. Try different pressures to determine the best ride comfort. See the Air Lift suggested driving air pressure for this vehicle.

3. Stability

Stability translates into safety and should be the priority, meaning the driver may need to sacrifice a perfectly level and comfortable ride. Stability issues include roll control, bounce, dive during braking and sponginess. Tuning out these problems usually requires additional air pressure, damping or both.

CHECKING FOR LEAKS

If the air suspension system develops a leak, follow these steps.

1. Inflate the air spring to maximum pressure as specified in the installation guide.
2. Spray all connections with a solution of liquid dish soap and water. Spot leaks easily by looking for bubbles in the soapy water.
3. After the test, deflate the springs to the minimum pressure required to restore the system to normal ride height.
4. Check the air pressure again after 24 hours. A 2-4 PSI (.14-.28BAR) loss after initial installation is normal. Retest for leaks if the loss is more than 5 PSI (.34BAR).



CUTTING AIR LINES

When cutting air lines, use a sharp knife or a hose cutter and make clean, square cuts. Do not use scissors or wire cutters because these tools will deform the air line, causing it to leak around fittings. Do not cut the lines at an angle.

The minimum bend radius for 1/4" air line is 1" (25mm). The minimum bend radius for 3/8" air line is 1 1/2" (38mm). Do not bend the air line less than the minimum bend radius or side load the fitting connections. Install air lines straight into fittings.



PREVENTING LEAKS AT PTC FITTINGS

After insertion, check the push-to-connect (PTC) fitting connection by pulling on each line to verify a robust connection.

To release the air line from the connection, first release all air from the system. Push in on the air line (step 1), push the collar in (step 2), and with the collar depressed, pull the air line out of the fitting (step 3).

The steps for reconnection are the same as disconnection.

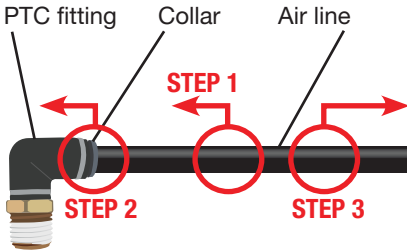

TIPS

- Cut off the end of the air line where it is indented by the PTC collar before reinstalling.
- If fitting is leaking at the threads, it may be necessary to remove and re-apply thread sealant on the threads and re-install 1 3/4 turns beyond finger tight.



CAUTION

MAKE SURE THE FRONT WHEELS ARE STRAIGHT WHEN DEFLATING AND REINFLATING AIR SPRINGS.

POST-INSTALLATION CHECKLIST

- Overnight leak down test** — Recheck air pressure 24 hours after installation and driving of the vehicle. If the pressure has dropped more than 5 PSI (.34BAR), there is a leak that must be fixed. Either fix the leak yourself or return to the installer for service.
- Air pressure requirements** — It is important to understand the air pressure requirements of the air spring system. Regardless of load, the air pressure should always be adjusted to maintain adequate ride height at all times while driving.
- Thirty-day or 800km (500-mile) test** — Recheck the air spring system after 30 days or 800km (500 miles), whichever comes first. If any part shows signs of rubbing or abrasion, the source should be identified and moved, if possible. If it is not possible to relocate the cause of the abrasion, the air spring may need to be remounted. If professionally installed, the installer should be consulted. Check all fasteners for tightness.

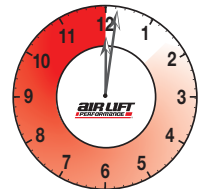

24-HOUR
Pressure check



OR

30
days

TROUBLESHOOTING GUIDE

PROBLEM	CAUSE	SOLUTION
Air spring won't maintain pressure.	Leak at fitting, air line not cut properly, air line has scratches that run lengthwise. or damage to air line during installation.	Find location of leak by spraying listed components with soapy water solution and look for bubbles. Tighten air fitting, re-cut air line or replace damaged components.
	Leak at lower O-ring on damper if air spring is over the damper.	Spray bottom of air spring with solution of water and dish soap and look for bubbles.
Knocking noise when hitting bumps.	Loose suspension component such as locking collar on damper or rod nut.	Tighten lower locking collar with significant force, check and tighten suspension components to factory specs at desired ride height. Replace rod nut, apply high strength threadlocker to clean threads and torque M12 rod nut to 54Nm (40 lb.-ft.). M10 rod nuts to be torqued to 38Nm (28 lb.-ft.).
	Driving vehicle too close to maximum extension.	Check current ride height and compare to maximum height. If there is less than 25mm (1") difference, reduce air pressure to lower ride height.
		Lengthen strut or shock to increase available up travel.
Suspension bottoms out.	Air pressure is too low, causing air springs to bottom out.	Raise air pressure.
The ride is too bouncy.	Air pressure is too high, causing air springs to be too stiff.	Lower air pressure and adjust damper length if necessary to achieve proper ride height.
	Damping is inadequate.	Increase damping with adjusters.
The ride is too soft or floaty.	Damping is inadequate.	
The ride is too harsh.	Excessive damping	Reduce damping with adjusters.
Rubbing sounds, wheel wells or other components show signs of rubbing.	Excessive camber, improper drop height adjustment, too little or too much air pressure,	Adjust camber, drop height adjustment and air pressure to find setup that does not cause rubbing.

AIR LIFT PERFORMANCE AIR MANAGEMENT

An Air Lift Performance air management system will allow you to get the most out of your #LifeOnAir.

THE MOST ADVANCED AIR MANAGEMENT



Air Lift Performance 3H[®] uses height and pressure sensors to provide the most innovative air suspension control system ever. Or opt for ALP 3P[®] with pressure sensors only. The third option in the ALP 3[®] system is 3S[®], which provides a lower-cost digital air management solution. All versions of ALP 3[®] allow users to download the free app to control their air suspension with a smartphone.



AutoPILOT™ V2

With AutoPilot V2, program favorite ride pressures and easily adjust suspension dynamics to compensate for additional passengers and cargo. With eight presets, owners can set one for “all up” one for “all down” and anywhere in between.



MANUAL AIR MANAGEMENT

Pressure control is adjusted with the simple push of the paddle valves which can be custom mounted into the dash or mounted to the supplied stainless steel panel. This is Air Lift's most affordable air management system.

