

Air Lift 1000™



Installation Instructions



Jeep Gladiator

Kit 60830

For maximum effectiveness and safety, please read these instructions completely before proceeding with installation.

Failure to read these instructions can result in an incorrect installation.

TABLE OF CONTENTS

Hardware and Tools Lists	2
Introduction	2
Notation Explanation2
Installing the System	3
Preparing the Vehicle3
Installing the Air Springs4
Installing the Air Lines	7
Before Operating	9
Installation Checklist9
Maintenance and Use Guidelines9

Hardware and Tools Lists

HARDWARE LIST

Item	Part#	Description	Qty
A	46123	Air spring.....	2
B	09111	Air spring spacer.....	2
C	20937	Air line	15ft.
D	10466	Zip ties	6
E	21230	Valve cap.....	2
F	21233	5/16" Hex nut.....	4
G	21234	Rubber washer.....	2
H	18411	Star washer.....	2
I	18501	M8 Flat washer.....	2
J	21236	Tee fitting.....	1
K	21455	Schrader valve	2
L	10638	Air line clamp	6

TOOLS LIST

Description.....	Qty
Ratchet.....	1
Pliers.....	1
Standard and metric regular and deep-well sockets	Set
5/16" drill bit (very sharp)	1
Heavy duty drill.....	1
Hose cutter, razor blade, or sharp knife	1
Hoist or floor jack	1
Safety glasses	1
Safety stands.....	2
Air compressor or compressed air source	1
Spray bottle with dish soap/water solution.....	1

Introduction

The purpose of this publication is to assist with the installation and maintenance of the Air Lift 1000 air spring kit.

Air Lift 1000 kits utilize a sleeve-style air bag that provides up to 1,000 pounds (454kg) of load-leveling support when installed into the vehicles coil springs. Each sleeve is rated at a maximum of 35 PSI (2.4BAR).

It is important to read and understand the entire installation guide before beginning installation or performing any maintenance, service or repair.

NOTATION EXPLANATION

Hazard notations appear in various locations in this publication. Information which is highlighted by one of these notations must be observed to help minimize risk of personal injury or possible improper installation which may render the vehicle unsafe. Notes are used to help emphasize areas of procedural importance and provide helpful suggestions. The following definitions explain the use of these notations as they appear throughout this guide.



DANGER

INDICATES IMMEDIATE HAZARDS WHICH WILL RESULT IN SEVERE PERSONAL INJURY OR DEATH.



WARNING

INDICATES HAZARDS OR UNSAFE PRACTICES WHICH COULD RESULT IN SEVERE PERSONAL INJURY OR DEATH.



CAUTION

INDICATES HAZARDS OR UNSAFE PRACTICES WHICH COULD RESULT IN DAMAGE TO THE MACHINE OR MINOR PERSONAL INJURY.

Installing the System

PREPARING THE VEHICLE

1. Mark the upper and lower springs and spring seats with a china marker, tire marker or white crayon to note its location (Fig. 1).



Mark spring location in reference to upper and lower spring seat. Sample of passenger's (right) side shown.

Fig. 1

2. Remove the lower shock bolts from both shocks (Fig. 2).



Fig. 2

3. Lift the vehicle up and support the frame with safety stands (Fig. 3). Drop the axle down low enough so the coil springs can be removed (axle hanging). Remove one spring at a time for installing the air springs. If necessary, pull down on the wheel or axle to create enough room for the springs to be removed.

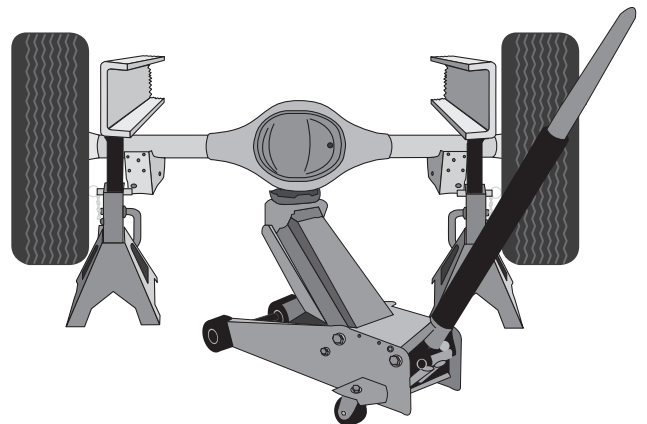

Fig. 3

4. With the spring removed, remove and discard the spring rubber isolators off the top of the coil springs (Fig. 4).

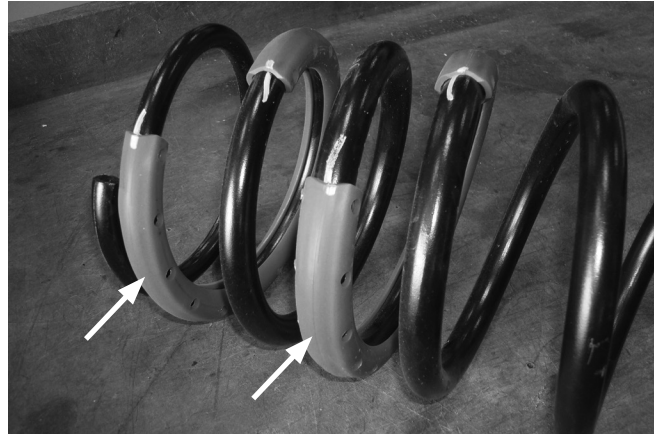

Fig. 4

INSTALLING THE AIR SPRINGS

1. Cut the air line (C) into two equal lengths. Using a pair of pliers, install the air line clamps (L) onto one end of each air line. Remove the valve caps (E) off the air springs (A) and install the air lines onto the barbed stem of the air springs. Slide the air line clamps over the barbed section of the stem on the air springs (Fig. 5).

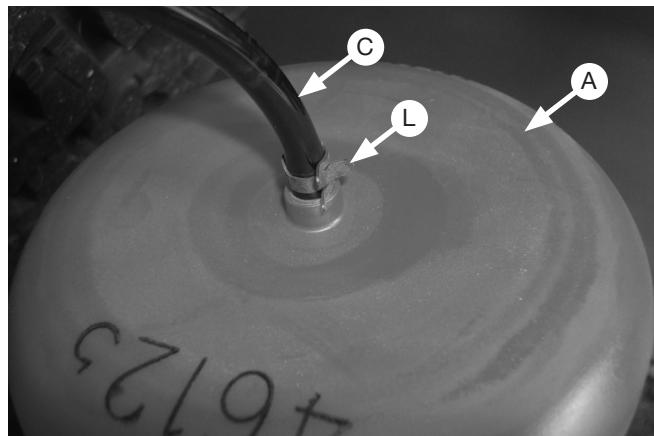
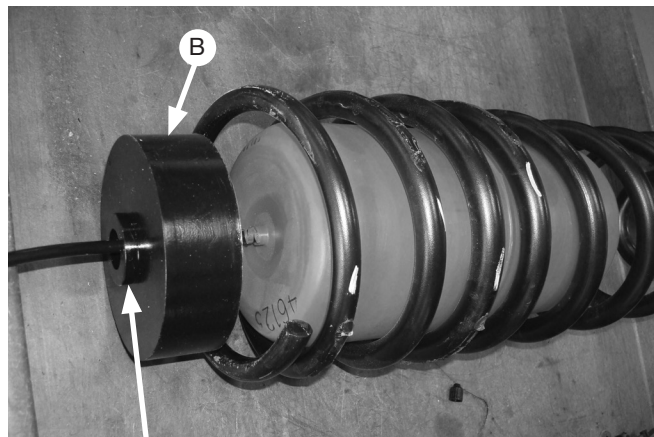

Fig. 5

2. Slide an air spring spacer (B) over each air line and onto the top of the air springs making sure the boss on the spacer is on the opposite side of the air spring (Fig. 6). Insert the assembly into the coil springs.



Boss on spacer must face away from the air spring.

Fig. 6

3. Set the rubber spring seat on top of the coil/air spring assemblies making sure the end of the coil spring is positioned correctly in the mount (the end of the coil spring indexes into the rubber spring seat only one way) (Fig. 7).

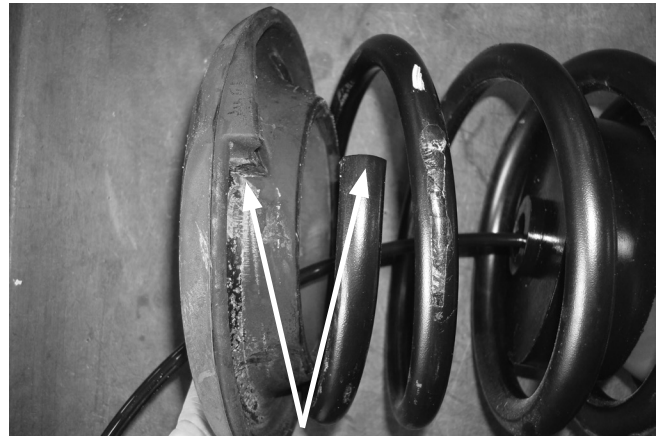

Spring indexes into the upper rubber spring mount.

Fig. 7

NOTE

On top of the rubber spring seat there is a tab (Fig. 8) that, once the coil/air spring assemblies are put into position, must index into the upper spring seat (Fig. 9). This, along with the marks made in step one, indexes the springs back into the vehicle correctly for alignment.



Fig. 8

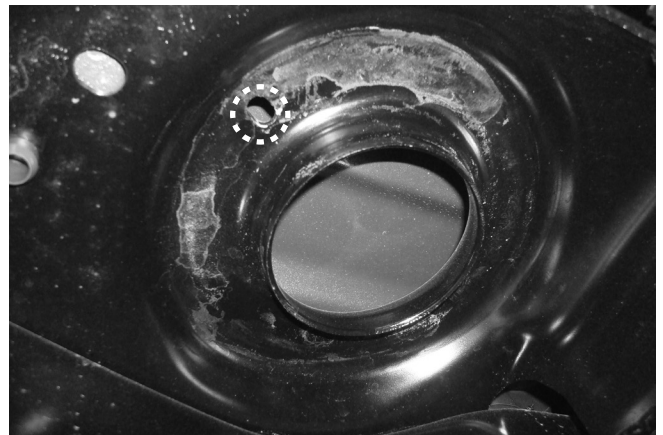

Fig. 9

⚠ CAUTION

ROUTE THE AIR LINE TO THE OUTSIDE OF THE FRAME RAIL ON THE DRIVER'S (LEFT) SIDE TO KEEP IT CLEAR OF THE EXHAUST ON THE INSIDE OF THE FRAME. ENSURE PROPER CLEARANCE AROUND THE EXHAUST TO AVOID DAMAGING THE AIR LINE.

4. Insert the air line through the hole in the upper spring seat mount and reinstall the coil/air spring assembly onto the axle, making sure the mark made on the axle and the upper index tab on the rubber spring seat mount, are positioned correctly (Fig. 10).
5. With both springs in position, raise the axle up far enough to insert the shock bolts back through the shocks. Install the nuts onto the bolts finger-tight, then raise the axle all the way up. Torque the lower shock bolts to 100 lb.-ft (135Nm).

Air line is on the outside of the driver's (left) side frame rail.

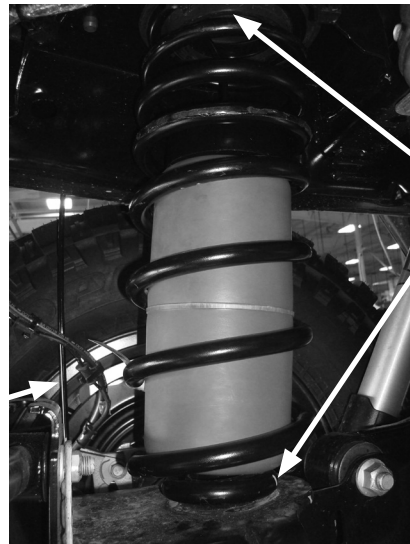

Tab on upper spring mount and marks on axle align correctly.

Fig. 10

6. Using the zip ties (D) and leaving slack in the air line above both spring seats for suspension articulation, tie each air line to the existing lines that are above the frame. Route the air line to the back (or side) of the vehicle and proceed with installing the air lines (Fig. 11).

Route air line on top of the frame, leaving slack above the spring seat.

Use zip ties to attach to existing lines.



Keep hose away from exhaust on the inside of the frame.

Fig. 11

Installing the Air Lines

1. A single-path air line installation is recommended for vehicles that typically have even weight distribution (Fig. 12). If weight in the vehicle varies from side to side and unequal pressures are needed to level the load, use a dual-path installation. For dual-path air line installations, eliminate the tee fitting (J) and route separate air lines for both air springs (Fig. 13).

Single-path Air Line Routing

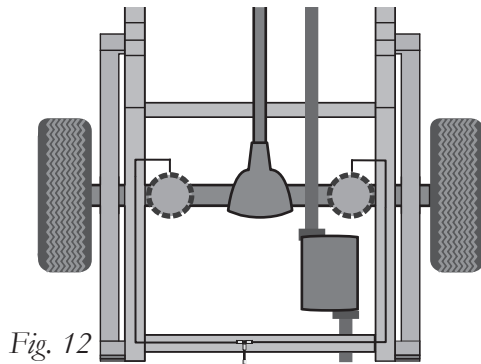

Dual-path Air Line Routing

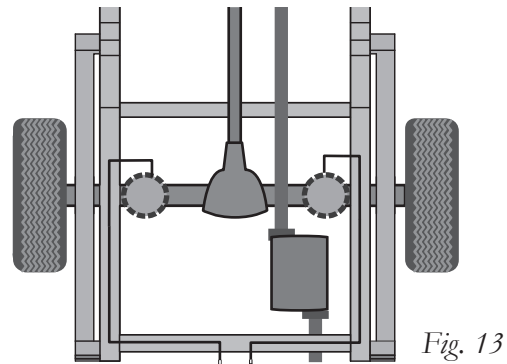

⚠ CAUTION

TO PREVENT THE AIR LINE FROM MELTING, MAINTAIN AT LEAST 6" (152MM) FROM THE EXHAUST SYSTEM TO THE AIR LINE.

2. If installing a single-path air line, choose a location for the tee fitting on the wheel well or rear bumper. Determine and cut adequate length of air line (C) (Fig. 14) to reach to the tee from left and right side air springs.

⚠ CAUTION

LEAVE SUFFICIENT AIR LINE SLACK TO PREVENT ANY STRAIN ON THE FITTING DURING AXLE MOTIONS.

3. Use this procedure (Fig. 15) for all air line connections:
 - a. Slide the air line clamp onto the air line.
 - b. Push the air line and air line clamp over the barbed stem so that the air line covers all the barbs.
 - c. Compress the ears on the air line clamp with pliers and slide it forward to fully cover the barbs.

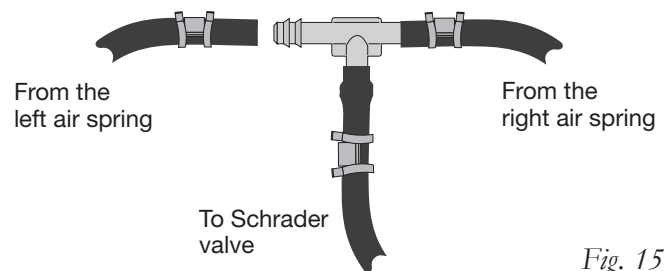
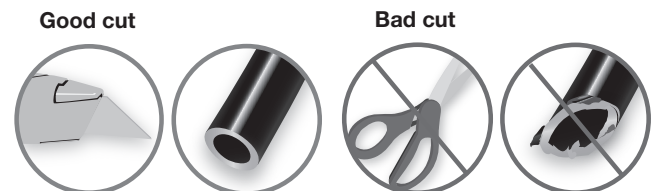

4. Select a location for the Schrader valve (K), ensuring that the valve will be protected and accessible with an air line (Fig. 16). Determine and cut adequate length of air line to reach from the tee to the Schrader valve or from the air springs to the valve if using a dual-path installation.

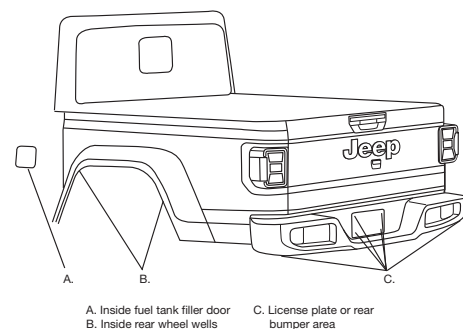

5. Drill a 5/16" (8mm) hole for the Schrader valve and mount as shown (Fig. 17). Install the air line on the Schrader valve first. The rubber washer serves as an outside weather seal.

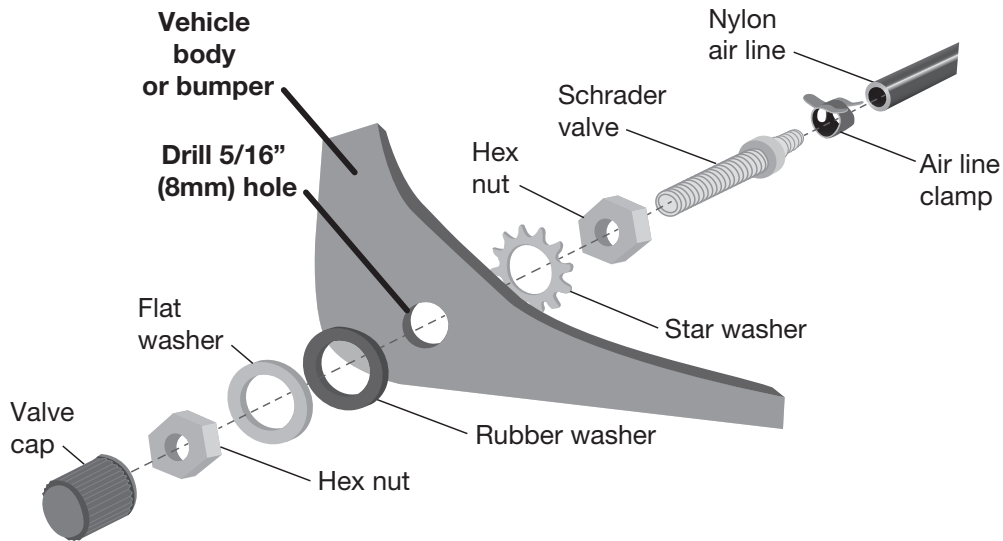

Fig. 17

CAUTION

DO NOT INFLATE THE AIR SPRINGS BEFORE READING THE MAINTENANCE AND USE GUIDELINES IN THIS INSTALLATION GUIDE AS WELL AS THE USER GUIDE INCLUDED WITH THIS KIT.

6. Once the air lines have been installed, remove the safety stands and inflate the air springs to 5 PSI (.34BAR).

Before Operating

INSTALLATION CHECKLIST

- Clearance test** — Inflate the air springs to 30 PSI (2BAR) and make sure there is at least 1/2" (13mm) clearance from anything that might rub against each air spring. Be sure to check the tire, brakes, frame, shock absorbers and brake cables.
- Leak test before road test** — Inflate the air springs to 30 PSI (2BAR) and check all connections for leaks. All leaks must be eliminated before the vehicle is road tested.
- Heat test** — Be sure there is sufficient clearance from heat sources, at least 6" (152mm) for air springs and air lines. If a heat shield was included in the kit, install it.
- Fastener test** — After 500 miles, recheck all bolts for proper torque.
- Road test** — The vehicle should be road tested after the preceding tests. Inflate the air springs to recommended driving pressures. Drive the vehicle 10 miles (16km) and recheck for clearance, loose fasteners and air leaks.
- Operating instructions** — If professionally installed, the installer should review the operating instructions with the owner. Be sure to provide the owner with all of the paperwork that came with the kit.

MAINTENANCE AND USE GUIDELINES

1. Check air pressure weekly.
2. Always maintain normal ride height. Never inflate beyond 35 PSI (2.4BAR).
3. If the system develops an air leak, use a soapy water solution to check all air line connections and the inflation valve core before deflating and removing the air spring.

Minimum Recommended Pressure	Maximum Air Pressure
5 PSI (.34BAR)	35 PSI (2.4BAR)

CAUTION

FOR SAFETY AND TO PREVENT POSSIBLE DAMAGE TO THE VEHICLE, DO NOT EXCEED MAXIMUM GROSS VEHICLE WEIGHT RATING (GVWR) OR PAYLOAD RATING, AS INDICATED BY THE VEHICLE MANUFACTURER.

ALTHOUGH THE AIR SPRINGS ARE RATED AT A MAXIMUM INFLATION PRESSURE OF 35 PSI (2.4BAR), THE AIR PRESSURE ACTUALLY NEEDED IS DEPENDENT ON LOAD AND GROSS VEHICLE WEIGHT RATING.