

Air Lift **1000HD**™

**Kit 60818HD**

***Dodge 1500 Pickup,  
2WD & 4WD***



## **INSTALLATION GUIDE**

For maximum effectiveness and safety, please read these instructions completely before proceeding with installation.

*Failure to read these instructions can result in an incorrect installation.*



# TABLE OF CONTENTS

<b>Installing the Air Lift 1000HD Kit</b> .....	<b>3</b>
Hardware List .....	3
Tools List .....	3
Getting Started .....	3
<b>Installing the Air Line</b> .....	<b>5</b>
Single-Path Air Line Routing .....	5
Dual-Path Air Line Routing .....	5
Complete the Installation .....	6
<b>Before Operating</b> .....	<b>7</b>
Installation Checklist .....	7
Maintenance and Use Guidelines .....	7



# Installing the Air Lift 1000HD Kit

## HARDWARE LIST

Item	Part #	Description .....	Qty
A	48179	Air spring.....	2
B	09960	Air spring protector .....	2
C	20937	Air line assembly.....	1
D	10466	Zip tie .....	6
E	21230	Valve cap.....	2
F	21233	5/16" Hex nut.....	4
G	21234	Rubber washer.....	2
H	18411	Star washer.....	2
I	18501	M8 Flat washer .....	2
J	21236	Tee fitting.....	1
K	21455	Schrader valve .....	2
L	10638	Air line clamp .....	6
M	21730	Straight pump connector.....	2

## TOOLS LIST

Description.....	Qty
Hoist or floor jack .....	1
Safety stands.....	2
Safety glasses .....	1
Spoon-type tire iron.....	1
Pliers.....	1
Sharp knife .....	1
Air compressor or compressed air source .....	1
Spray bottle with dish soap/water solution.....	1

## GETTING STARTED

1. Jack up the rear of the vehicle or raise on a hoist. Support the frame with safety stands (Fig. 1). Lower the axle or raise the body of the vehicle until the springs are completely extended.

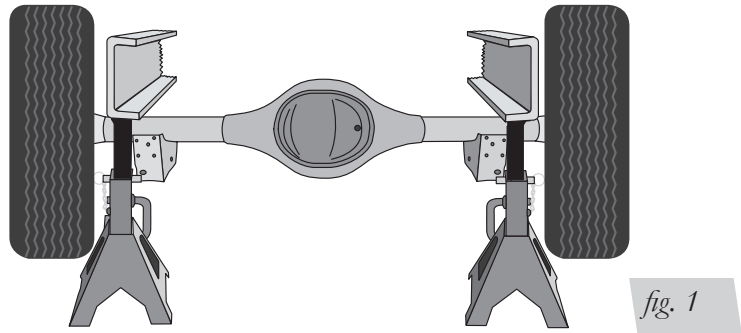

2. Some models may have a rubber isolator at the top of the passenger's side coil spring. This isolator needs to be removed and can be discarded (Fig. 2).

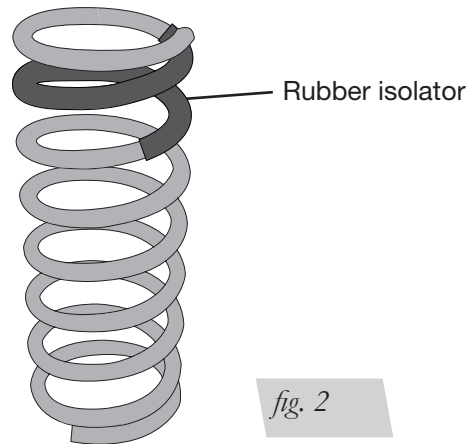

3. Remove the plastic cap from the barbed stem on the end of the air spring (A). Exhaust the air from the air spring by rolling it up toward the stem. Replace the cap on the stem to hold the flat shape (Fig. 3). Fold air spring into a “hot dog bun” shape.

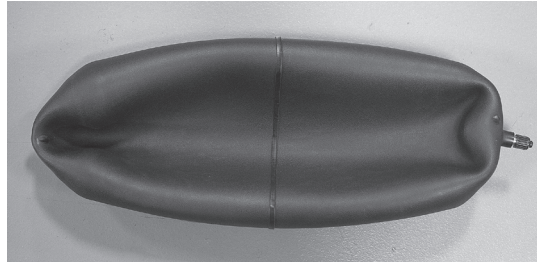
*fig. 3*

4. Insert the flattened air spring into the coil spring through the lowest opening with the stem at the top (Fig. 4). Push the air spring up within the coil by hand or with a blunt instrument such as a spoon-type tire iron.

 **CAUTION**

DO NOT USE A SHARP OBJECT TO PUSH THE AIR SPRING INTO PLACE.

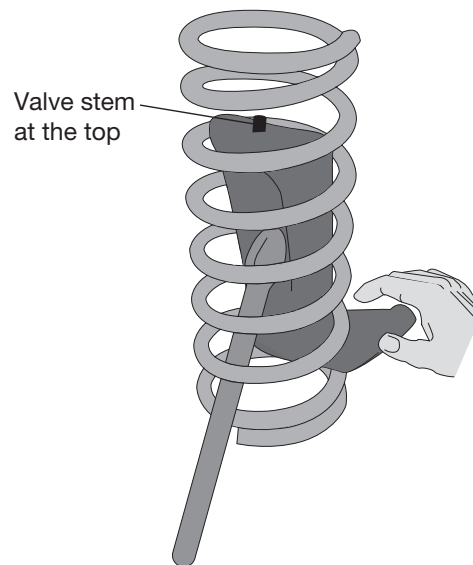
*fig. 4*

5. When the air spring is completely within the coil, remove the cap and allow the air spring to assume its “as-molded shape.” Push the cylinder down to the bottom of the coil spring so that the stem at the top can be accessed for attaching the hose.

# Installing the Air Line

A single-path air line installation is recommended for vehicles that typically have even weight distribution (Fig. 5). If weight in the vehicle varies from side to side and unequal pressures are needed to level the load, use a dual-path installation. For dual-path air line installations, eliminate the tee fitting (J) and route separate air lines for both air springs (Fig. 6).

## Single-path Air Line Routing

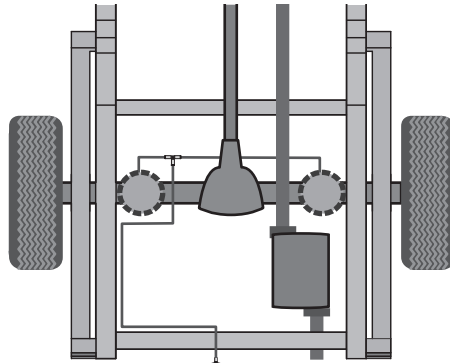

fig. 5

## Dual-path Air Line Routing

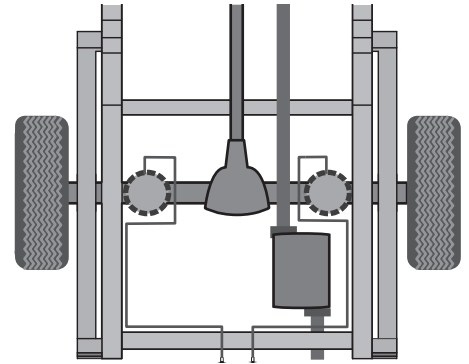

fig. 6

**CAUTION**

TO PREVENT THE AIR LINE FROM MELTING, MAINTAIN AT LEAST 6" (152MM) FROM THE EXHAUST SYSTEM TO THE AIR LINE.

1. If installing a single-path air line, choose a location for the tee fitting (J) on the frame rail or crossmember. Determine and cut adequate length of air line (C) to reach from tee to the left and right side air springs.

**CAUTION**

LEAVE SUFFICIENT AIR LINE SLACK TO PREVENT ANY STRAIN ON THE FITTING DURING AXLE MOTIONS.

2. Use this procedure (Fig. 7) for all air line connections:
  - a. Slide the air line clamp (L) onto the air line.
  - b. Push the air line and air line clamp over the barbed stem so that the air line covers all the barbs.
  - c. Compress the ears on the air line clamp with pliers and slide it forward to fully cover the barbs.
3. Select a location for the Schrader valve (K), ensuring that the valve will be protected and accessible with an air hose (Fig. 8). Determine and cut adequate length of air line (C) to reach from the tee to the Schrader valve or from the air springs to the valve if using a dual-path installation.

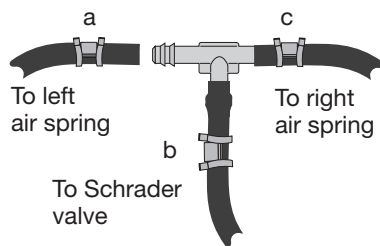

fig. 7

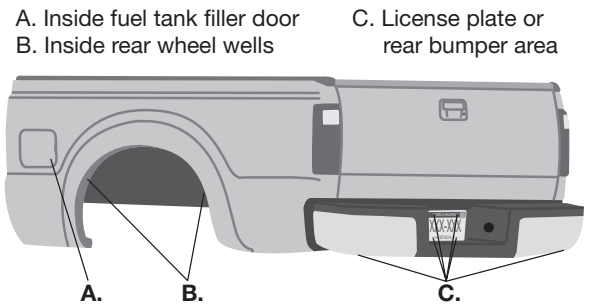

fig. 8

4. Drill a 5/16" (8mm) hole for the Schrader valve (K) and mount as shown (Fig. 9). Install the air line on the Schrader valve first. The rubber washer (G) serves as an outside weather seal.

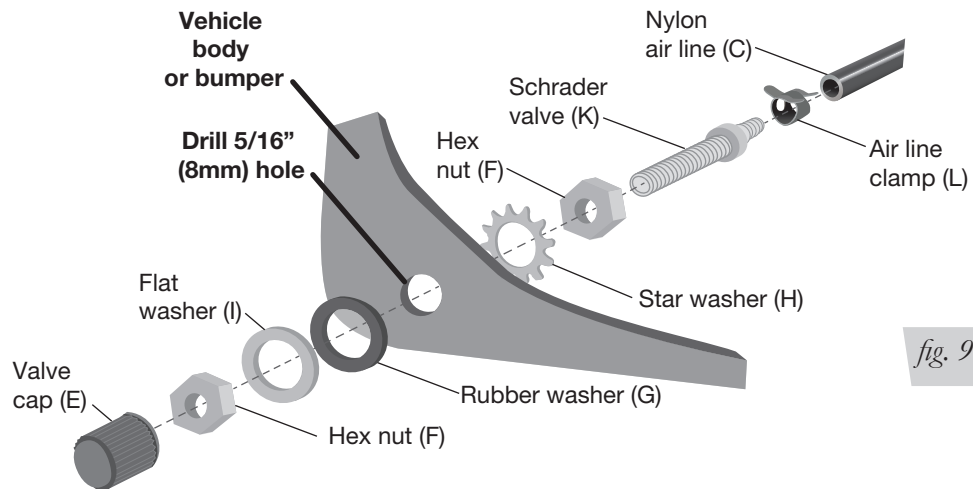

fig. 9

5. From the tee, route the air line along the top of the frame on both sides to, and down through the top spring seats, through an air spring protector (B) to the air springs (Fig. 10). Leave sufficient slack to prevent any strain on the fitting during axle motions. Cut the air line to length using a sharp knife.

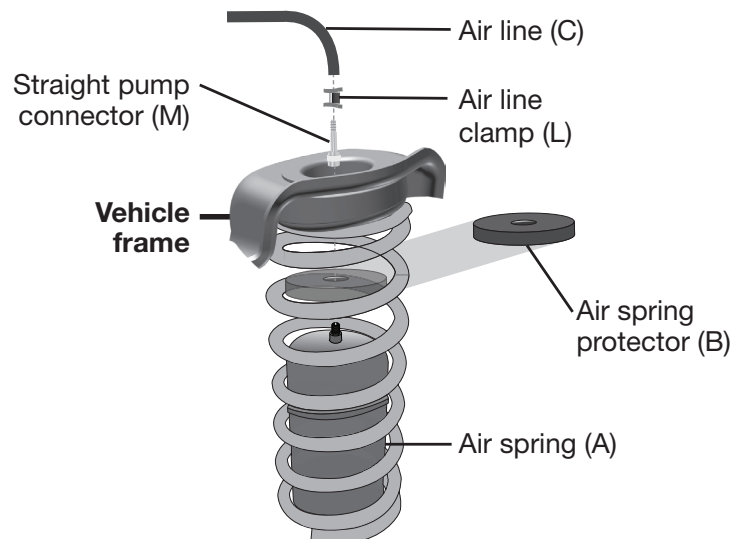

fig. 10

6. Attach the straight pump connector (M) to the air line (Fig. 10). Attach the straight pump connector to the air spring fitting. Do not use any tools to tighten the fitting.

**CAUTION**

DO NOT INFLATE THE AIR SPRINGS BEFORE READING THE MAINTENANCE AND USE GUIDELINES IN THIS INSTALLATION GUIDE AS WELL AS THE USER GUIDE INCLUDED WITH THIS KIT.

## COMPLETE THE INSTALLATION

1. Once the air lines have been installed, raise the suspension or lower the body so that the air spring just touches the top and the bottom of the upper and lower spring mounts. Inflate the air springs to 5 PSI (.34BAR).
2. Remove the safety stands and lower the vehicle.

# Before Operating

Consult the included User Guide for information about fixing air leaks along with more tips for maintenance and use before using the product.

## INSTALLATION CHECKLIST

- Clearance test** — Inflate the air springs to 25-35 PSI (1.7-2.4BAR) and make sure there is at least 1/2" (13mm) clearance from anything that might rub against each air spring.
- Leak test before road test** — Inflate the air springs to 25-35 PSI (1.7-2.4BAR) and use a soapy water solution to check all connections for leaks. All leaks must be eliminated before the vehicle is road tested.
- Heat test** — Be sure there is sufficient clearance from heat sources, at least 6" (152mm) for air springs and air lines.
- Road test** — The vehicle should be road tested after the preceding tests. Inflate the air springs so that the vehicle is level. Drive the vehicle 10 miles (16km) and recheck for clearance, loose fasteners and air leaks.
- Operating instructions** — If professionally installed, the installer should review the User Guide with the owner. Be sure to provide the owner with all of the paperwork that came with the kit.

## MAINTENANCE AND USE GUIDELINES

1. Check air pressure weekly.
2. Always maintain normal ride height. Never inflate beyond 50 PSI (3.5BAR).
3. If the system develops an air leak, use a soapy water solution to check all air line connections and the inflation valve core before deflating and removing the air spring.

Minimum Recommended Pressure	Maximum Air Pressure
<b>5 PSI (.34BAR)</b>	<b>50 PSI (3.5BAR)</b>

### CAUTION

FOR SAFETY AND TO PREVENT POSSIBLE DAMAGE TO THE VEHICLE, DO NOT EXCEED MAXIMUM GROSS VEHICLE WEIGHT RATING (GVWR) OR PAYLOAD RATING, AS INDICATED BY THE VEHICLE MANUFACTURER.

### CAUTION

ALTHOUGH THE AIR SPRINGS ARE RATED AT A MAXIMUM INFLATION PRESSURE OF 50 PSI (3.5BAR), THE AIR PRESSURE ACTUALLY NEEDED IS DEPENDENT ON LOAD AND GROSS VEHICLE WEIGHT RATING.