

LoadLifter 5000™ SERIES



Installation Instructions



Ford Ranger

Kits 57234 | 88234

For maximum effectiveness and safety, please read these instructions completely before proceeding with installation.

Failure to read these instructions can result in an incorrect installation.

TABLE OF CONTENTS

Installation Diagram	2
Hardware and Tools Lists	3
Introduction	4
Notation Explanation	4
Identifying the Differences Between Kits	4
Installing the System	5
Preparing the Vehicle	5
Installing the Upper Brackets	6
Assembling the Air Spring	6
Installing the Air Spring Assemblies	8
Installing the Air Lines	10
Installing the Heat Shield	11
Finished Installation	12
Installation Checklist	13
Maintenance and Use Guidelines	13

Video-enhanced installation guides

Installation Diagram

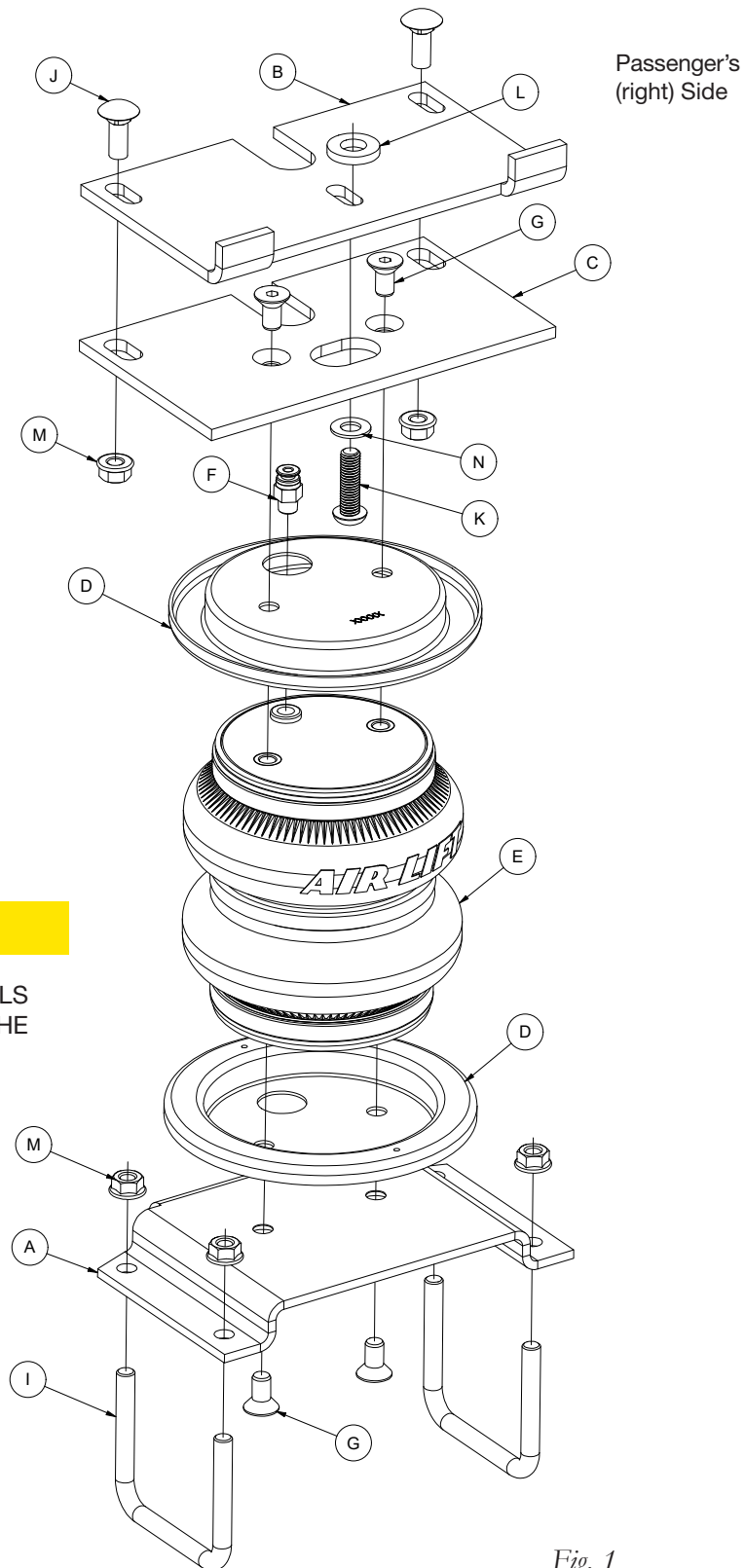

⚠ CAUTION

PROFESSIONAL MECHANIC SKILLS ARE REQUIRED TO COMPLETE THE INSTALLATION OF THIS KIT.

Fig. 1

Hardware and Tools Lists

Common Parts Included in All 3 Kits

Item	Part#	Description	Qty
A	03039	Lower bracket	2
B	07059	Upper frame bracket	2
C	07065	Upper air spring bracket	2
F	21839	Straight air fitting	2
G	17215	3/8"-24 x 3/4" Flat head screw	8
H*	10465	5/8" P-clamp	1
I	10975	3/8"-16 x 3" U-bolt	4
J	17134	3/8"-16 x 1" Carriage bolt	4
K	17366	M10 -1.5 x 35 Button head cap screw	2
L	18414	1/2" Flat washer	2
M	18422	3/8" Serrated flange lock nut	12
N	18444	3/8" Flat washer	2
AA*	20086	Air line assembly	1
BB*	10466	Zip ties	6
CC*	18411	5/16" Lock washer	2
DD*	21234	Rubber washer	2
EE*	18501	M8 Flat washer	2
FF*	21233	5/16" Hex nut	4
GG*	21230	Valve cap	2

* These parts are not shown in the Installation Diagram (Fig.1).

Unique Parts in Each Kit

LoadLifter 5000™ KIT 57234

Item	Part#	Description	Qty
D	11951	Roll plate	4
E	58439	Air spring	2

LoadLifter 5000™ **ULTIMATE** KIT 88234

Item	Part#	Description	Qty
D	11967	Roll plate	4
E	58494	Air spring	2

TOOLS LIST

Description	Qty
Standard and metric open-end or boxed wrenches	Set
Standard and metric regular and deep-well sockets	Set
Ratchet	1
Torque wrench	1
7/32" hex-key wrench (socket preferable)	1
Hose cutter, razor blade, or sharp knife	1
Hoist or floor jack	1
Safety stands	2
Safety glasses	1
Air compressor or compressed air source	1
Spray bottle with dish soap/water solution	1

The photos in this manual show the LoadLifter 5000 kit.

Introduction

The purpose of this publication is to assist with the installation and maintenance of the LoadLifter 5000 series air spring kits. All LoadLifter 5000 series kits utilize sturdy, reinforced, commercial-grade single or double, depending on the kit, convolute bellows.

The air springs are manufactured like a tire with layers of rubber and cords that control growth. LoadLifter 5000 kits provide up to 5,000 pounds (2,268kg) of load-leveling support with air adjustability from 5-100 PSI (.34-7BAR).

It is important to read and understand the entire installation guide before beginning installation or performing any maintenance, service or repair.

NOTATION EXPLANATION

Hazard notations appear in various locations in this publication. Information which is highlighted by one of these notations must be observed to help minimize risk of personal injury or possible improper installation which may render the vehicle unsafe. Notes are used to help emphasize areas of procedural importance and provide helpful suggestions. The following definitions explain the use of these notations as they appear throughout this guide.

DANGER

INDICATES IMMEDIATE HAZARDS WHICH WILL RESULT IN SEVERE PERSONAL INJURY OR DEATH.

WARNING

INDICATES HAZARDS OR UNSAFE PRACTICES WHICH COULD RESULT IN SEVERE PERSONAL INJURY OR DEATH.

CAUTION

INDICATES HAZARDS OR UNSAFE PRACTICES WHICH COULD RESULT IN DAMAGE TO THE MACHINE OR MINOR PERSONAL INJURY.

IDENTIFYING THE DIFFERENCES BETWEEN KITS

Should you need to contact Air Lift customer service, you will need to know which kit you are inquiring about: standard LoadLifter 5000 or LoadLifter 5000 Ultimate. The kits are easily identifiable by looking at the roll plates.

- Standard **LoadLifter 5000** — Zinc-plated steel roll plates and black nylon air lines.
- LoadLifter 5000 Ultimate** — Black powder-coated roll plates and black nylon air lines.



LoadLifter 5000
silver zinc-plated steel
roll plate



LoadLifter 5000
nylon air line



LoadLifter 5000 Ultimate
black powder-coated roll plate



LoadLifter 5000 Ultimate
nylon air line

Installing the System

PREPARING THE VEHICLE

1. Lift the vehicle and support the frame with safety stands. Drop the axle down low enough to later set the air spring assemblies into position between frame and leaf spring (Fig. 2). Remove the rear wheels.

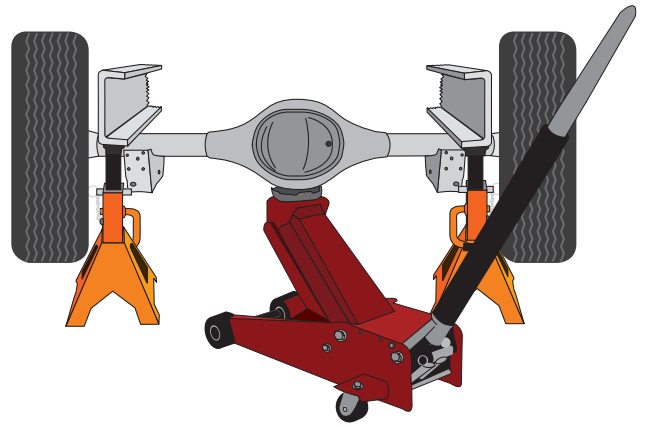

Fig. 2

2. Remove the jounce bumper assembly by using a metric socket and extension. You can access the bolt by using the hole in the middle of the jounce bumper (Fig. 3). Discard jounce bumper assembly.

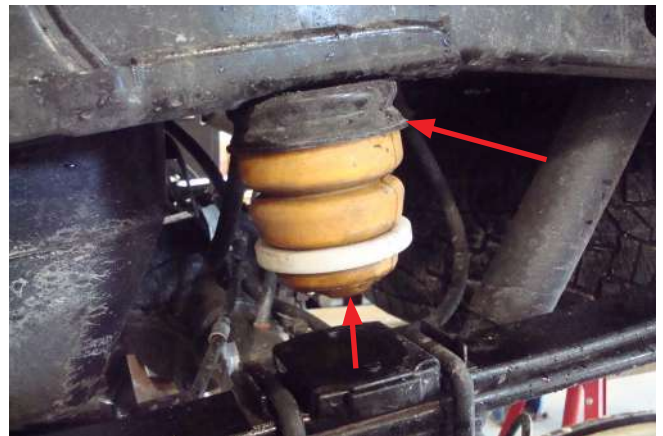

Fig. 3

3. Move the vent tube line holder that is around the emergency brake cable, inward until it aligns with the vent tube that is bolted into the axle (Fig. 4). Attach a zip tie (BB) around the emergency brake cable to prevent the holder from moving toward the tire.

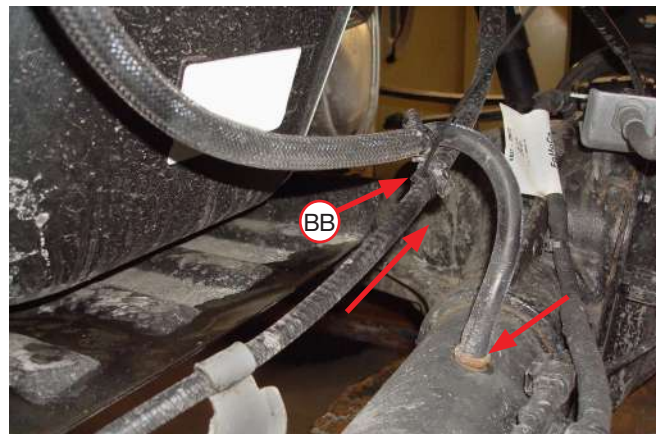

Fig. 4

INSTALLING THE UPPER BRACKETS

1. Insert an M10 button head cap screw (K) through a 3/8" flat washer (N), then through the upper frame brackets (B) and 1/2" flat washer (L). Install the assembly using the existing jounce bumper hole. Align the bracket so the flanges are up against the frame and torque the mounting hardware to 31 lb.-ft. (42Nm) (Fig. 5 & Fig. 6).

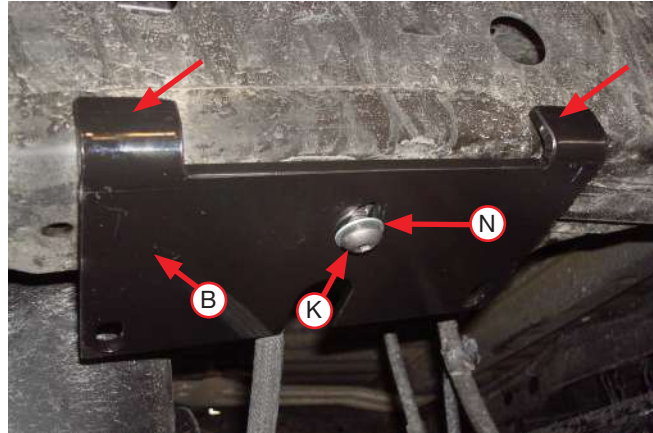

Fig. 5



Fig. 6

ASSEMBLING THE AIR SPRING

1. Place the roll plates (D) on the air springs (E) (Fig. 7). Install the straight air fittings (F) onto the air springs. Tighten the air fittings finger tight plus 1 1/2 turns.

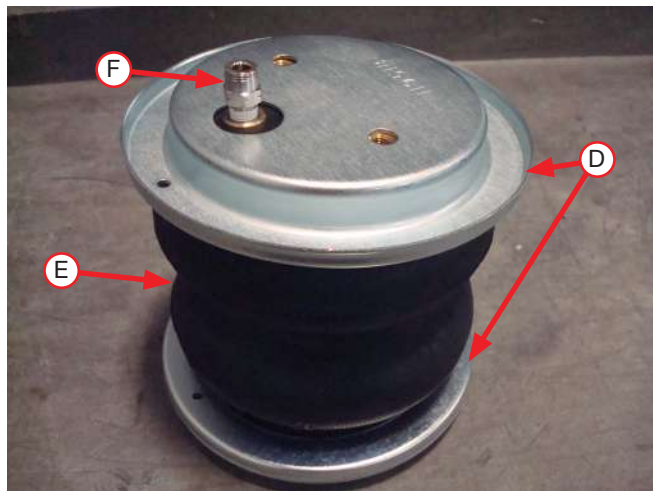

Fig. 7

- Set the upper air spring bracket (C) onto the air spring assembly and attach with flat head screws (G) (Fig. 8). Torque to no more than 20lb.-ft. (27Nm).

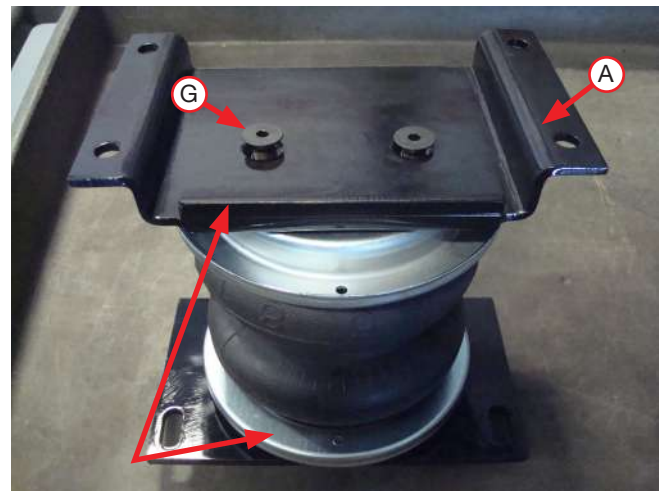

Fig. 8

CAUTION

USE CAUTION WHEN FLIPPING THE AIR SPRING ASSEMBLIES SO AS NOT TO DAMAGE THE FITTINGS.

- Flip both air springs over so the fitting is down. Install the lower brackets (A) so that the flange on the lower bracket is on the fitting side of the air spring (Fig. 9). Attach using the flat head screws (G). Torque to no more than 20 lb.-ft. (27Nm).



The flange on the lower bracket must be on the same side as the fitting.

Fig. 9

NOTE

Fig. 10 shows the completed assemblies.



Fig. 10

INSTALLING THE AIR SPRING ASSEMBLIES

1. Starting on the driver's (left) side, set a U-bolt (I) into position under the leaf spring, forward of the axle. This will rest on top of the emergency brake cable as shown (Fig. 11). Repeat for the passenger's (right) side.



Fig. 11

2. With the suspension dropped, as instructed in step 1 of "Preparing the Vehicle," set the air spring assemblies onto the leaf springs, making sure the fittings and flanges are pointing inboard (Fig. 12). Insert the U-bolts into the front side of the lower brackets while placing the assemblies into position. Insert the back-side U-bolts through the lower brackets and install the 3/8" serrated flange lock nuts (M) onto the U-bolts finger-tight only.



Fig. 12

3. Insert the 3/8" carriage bolts (J) into the top frame brackets from the top down (Fig. 13).



Fig. 13

4. While raising the axle up or lowering the frame, align the upper air spring brackets so the 3/8" carriage bolts go through the slots in the upper air spring brackets (Fig. 14). Install the 3/8" serrated flange lock nuts (M) onto the carriage bolts after the brackets meet each other. Leave loose at this time.

*Fig. 14*

5. Align the air spring assemblies in and out, then rotate so that the lower brackets are perpendicular to the leaf springs (Fig. 15). Once aligned, torque the lower brackets mounting hardware to 15 lb.-ft. (20Nm). Finish by torquing the upper bracket mounting hardware to 31lb.-ft. (42Nm).

NOTE

Upper frame and lower bracket may be on a slight angle to each other, this is an acceptable condition.



Rotate the air spring assemblies so that the lower brackets are perpendicular to the leaf springs before tightening all hardware.

Fig. 15

Installing the Air Lines

⚠ CAUTION

KEEP AT LEAST 6" (150MM) OF CLEARANCE BETWEEN ALL AIR LINES AND THE EXHAUST SYSTEM. AVOID SHARP BENDS AND EDGES.

1. Air lines are routed from the Schrader valve mounting location (already attached to the end of the hose), to the air springs. Begin by choosing locations for the Schrader valves and drill a 5/16" (8mm) hole, if necessary (Fig. 16).

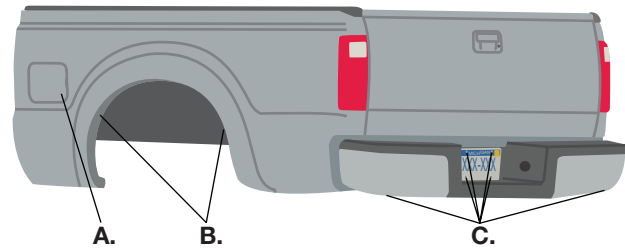

* For LoadLifter 5000 Ultimate Plus kits, the recommended location for the Schrader valves is the rear bumper area or license plate.

A. Inside fuel tank filler door B. Inside rear wheel wells C. License plate or rear bumper area*

Fig. 16

2. Cut the air line in half. Make clean, square cuts with a razor blade or hose cutter (Fig. 17). Do not use scissors or wire cutters.

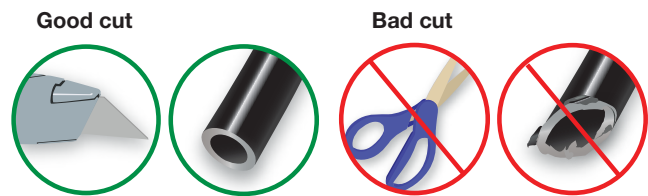

Fig. 17

3. Install the Schrader valve in the chosen location (Fig. 18).

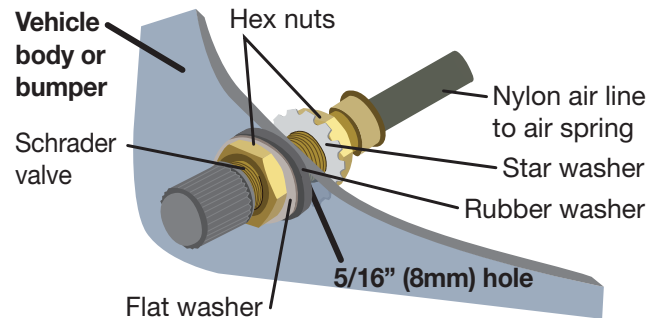

Fig. 18

4. For the air line routing on the passenger's side, route the air line along the top or outside frame rail (if the Schrader valve is located behind the axle). Where the inner fender is attached to the frame, there are two plastic mounting pins (Fig. 19), remove the rear pin by unscrewing it. Insert the pin into the 5/8" P-clamp (H) and re-attach to the inner fender. Route the air line through this P-clamp forward of the axle and over the frame to the inside above the air spring assembly.

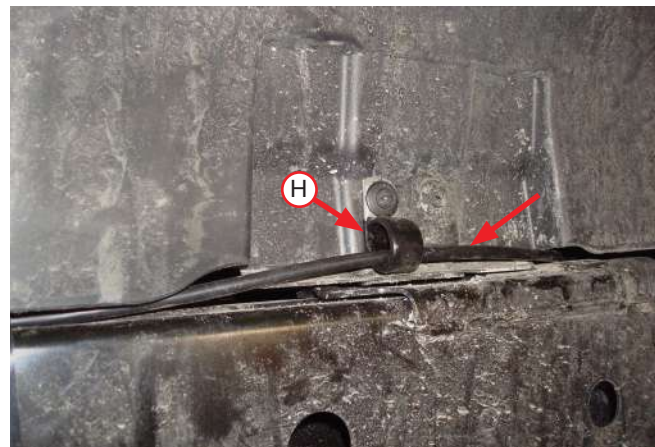
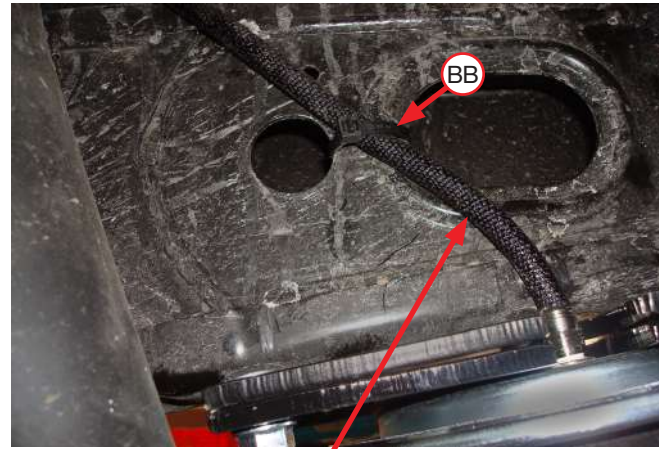

Fig. 19

- Leaving a little slack in the air line, cut to length and install the air line thermal sleeve over the air line (Fig. 20). While pushing the air line into the fitting on top of the air spring, wiggle it to make sure it bottoms out. Slide the air line thermal sleeve down to the fitting and attach the air line to the frame with a zip tie (BB) as shown.



Air line thermal sleeve

Fig. 20

- For the air line on the driver's (left) side, route the air line to the air springs making sure that the air line goes in between the wiring, brake lines and the frame (Fig. 21). Leave some slack, cut to length and insert the air line in the fitting.
- Finish the installation by raising the axle up far enough to remove the safety stands. Remove the safety stands and install the wheels. Torque the lug nuts in a crisscross pattern to factory specification.



Make sure air line is routed between the wiring, brake line, and frame.

Fig. 21

INSTALLING THE HEAT SHIELD

- Attach the metal heat shield to the exhaust where it is closest to the passenger's (right) side air spring (Fig. 22 & Fig. 23)

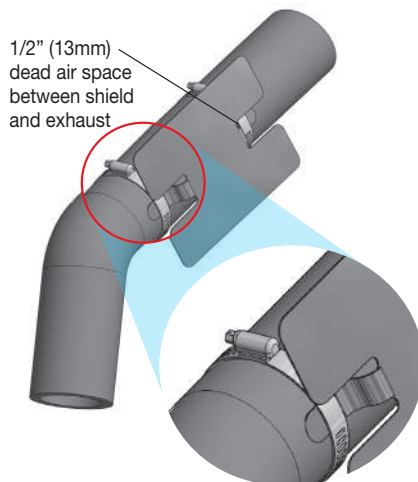

Fig. 22



Fig. 23

Finished Installation

The images show the finished installation of both sides (Fig. 24 - Fig. 27).



Inside view of driver's (left) side installation. *Fig. 24*



Back, outside view of driver's (left) side installation. *Fig. 25*



Back, outside view of passenger's (right) side installation. *Fig. 26*



Forward, outside view of passenger's (right) side installation. *Fig. 27*

INSTALLATION CHECKLIST

- Clearance test** — Inflate the air springs to 40-60 PSI (2.8-4.1BAR) and make sure there is at least 1/2” (13mm) clearance from anything that might rub against each sleeve. Be sure to check the tire, brakes, frame, shock absorbers and brake cables.
- Leak test before road test** — Inflate the air springs to 30 PSI (2.1BAR) and check all connections for leaks with a soapy water solution. All leaks must be eliminated before the vehicle is road tested. Refer to the User Guide provided with this kit.
- Heat test** — Be sure there is sufficient clearance from heat sources, at least 6” (152mm) for air springs and air lines. If a heat shield was included in the kit, install it.
- Fastener test** — After 500 miles, recheck all bolts for proper torque.
- Road test** — The vehicle should be road tested after the preceding tests. Inflate the springs to recommended driving pressures. Drive the vehicle 10 miles (16km) and recheck for clearance, loose fasteners and air leaks.
- Operating instructions** — If professionally installed, the installer should review the operating instructions with the owner. Be sure to provide the owner with all of the paperwork that came with the kit.

MAINTENANCE AND USE GUIDELINES

1. Check air pressure weekly.
2. Always maintain normal ride height. Never inflate beyond 100 PSI (7BAR).
3. If the system develops an air leak, use a soapy water solution to check all air line connections and the inflation valve core before deflating and removing the air spring.

Minimum Recommended Pressure
5 PSI (.34BAR)

Maximum Air Pressure
100 PSI (7BAR)

CAUTION

FOR SAFETY AND TO PREVENT POSSIBLE DAMAGE TO THE VEHICLE, DO NOT EXCEED MAXIMUM GROSS VEHICLE WEIGHT RATING (GVWR) OR PAYLOAD RATING, AS INDICATED BY THE VEHICLE MANUFACTURER.

ALTHOUGH THE AIR SPRINGS ARE RATED AT A MAXIMUM INFLATION PRESSURE OF 100 PSI (7BAR), THE AIR PRESSURE ACTUALLY NEEDED IS DEPENDENT ON LOAD AND GROSS VEHICLE WEIGHT RATING.