



WirelessONE™

Kit Number
25980

On-Board Air Compressor System with Wireless Controller Smartphone App

Introduction

WirelessONE components include a wireless controller, manifold, wiring harness, compressor and accessories needed to connect to vehicle power as well as to the air springs (purchased separately).

It is important to read and understand the entire installation guide before beginning installation or performing any maintenance, service or repair. The information here includes a hardware list, step-by-step installation information and safety information.

USING THE SYSTEM

Refer to the WirelessONE User Guide included with this kit to learn how to operate the system.



NOTATION EXPLANATION

Hazard notations highlight information that must be observed to help minimize risk of personal injury or possible improper installation, which may render the vehicle unsafe.



INDICATES IMMEDIATE HAZARDS WHICH WILL RESULT IN SEVERE PERSONAL INJURY OR DEATH.



INDICATES HAZARDS OR UNSAFE PRACTICES WHICH COULD RESULT IN SEVERE PERSONAL INJURY OR DEATH.



INDICATES HAZARDS OR UNSAFE PRACTICES WHICH COULD RESULT IN DAMAGE TO THE MACHINE OR MINOR PERSONAL INJURY.

TOOLS LIST

Description.....	Qty
Power drill.....	1
5/32" Drill bit.....	1
Grinder.....	1
4mm hex bit/bit driver	1
3/8" socket and ratchet.....	1
Wire stripping/crimping tool.....	1
Sharp razor knife	1



HARDWARE LIST

Item	Part #	Description	Qty
A	72719	Wireless controller	1
B	72708	Wireless manifold	1
C	16060	Compressor	1
D	20946	Air line (1/4")	20 ft.
E	26896	Wiring harness	1

Hardware Pack

F	21838	Tee 1/4" PTC	2
G	24652	ATC fuse, spade 15A	1
H	24752	Heat shrink butt splice 12-10 ga	2
I	24500	Fuse holder ATC/ATO	1
J	10466	8" Zip tie	15
K	24748	3/8" Ring terminal	2
L	17509	M5x1.5 x 30 Self-tapping socket cap screw*	5

* Extra screws included for attaching the manifold

Installing WirelessONE

ORDER OF INSTALLATION

1. Start by mounting the compressor (C).
2. Mount the manifold (B). It should be located no more than 32" (81cm) from the compressor.
3. Cut off the terminal on the red compressor wire before connecting to the wiring harness (E). Route the harness (E) and air lines (D) along the frame and make all wiring and air line connections. Finish by connecting the wiring to the battery. Install the fuse (G) last.

MOUNTING THE COMPRESSOR

1. The compressor can be mounted in any orientation: sideways, upside down or top up.
2. Use the compressor as a template and mount with the hardware included with the compressor.
3. The compressor ground wire must have a good connection to the frame. It may be necessary to grind some paint or rust off the frame to make good contact.

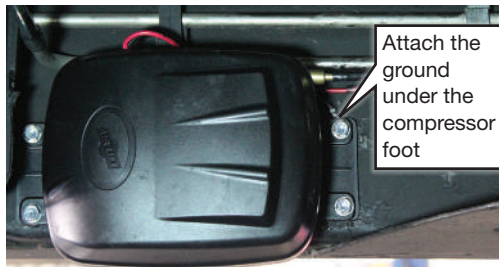

MOUNTING THE MANIFOLD

1. The manifold can be mounted in any orientation except upside down or with the electrical connector pointed down.
2. Use the included mounting template for mounting the manifold. Use a 5/32" drill bit to make pilot holes. Ideally, the manifold should be mounted in the middle of the vehicle. It must be mounted forward of the rear axle. Use a 4mm hex bit to install the screws (L).

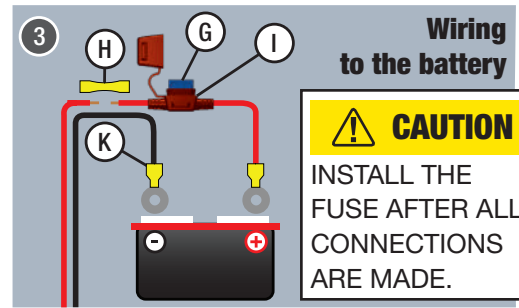
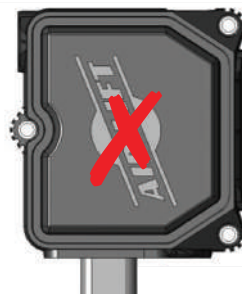

OPTIONAL Ignition Source Connection

Connect the pink wire to any wire that is active when the ignition is on. This will allow WirelessONE to make adjustments as soon as the ignition is turned on. Otherwise, the system will only activate when the vehicle moves or when woken up by the controller or mobile app. Hardware to connect to the ignition is not included. This is a low-amperage circuit that should be connected to the output side of a 10A or smaller fuse-protected circuit.

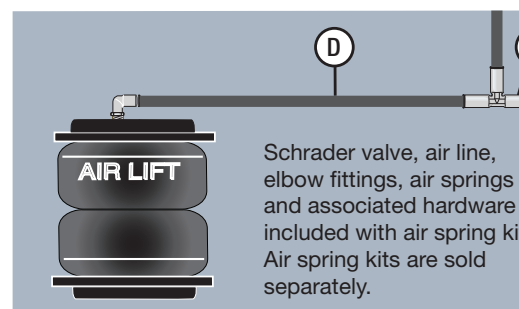
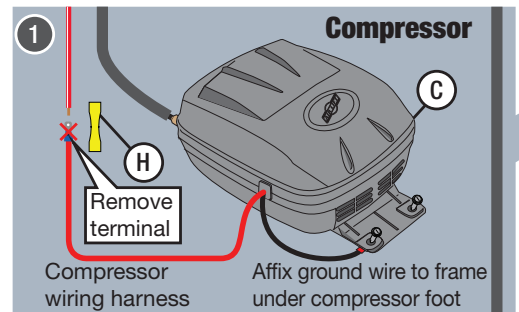
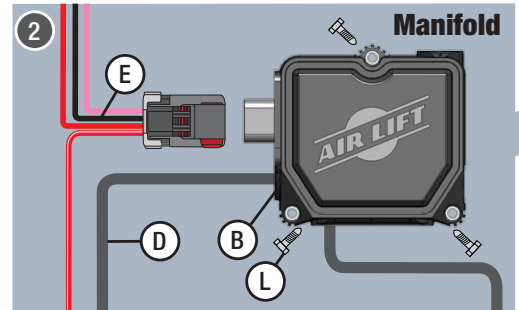
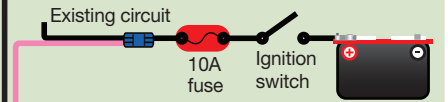

SUGGESTED COMPONENT LAYOUT

This guide should be used as a general reference. The layout may need modification based on the application.

- Ideally, the manifold and compressor should be mounted in the middle of the vehicle in the zone marked by the yellow square to optimize the wireless performance.
- Avoid routing air lines and wiring near sharp edges. If passing air lines or wiring through holes in the frame, use rubber grommets. Support wiring and air lines every 8-12" (20-30cm) with zip ties or other means.
- Keep wiring and air lines, manifold and compressor at least 6" away from heat sources such as the exhaust.

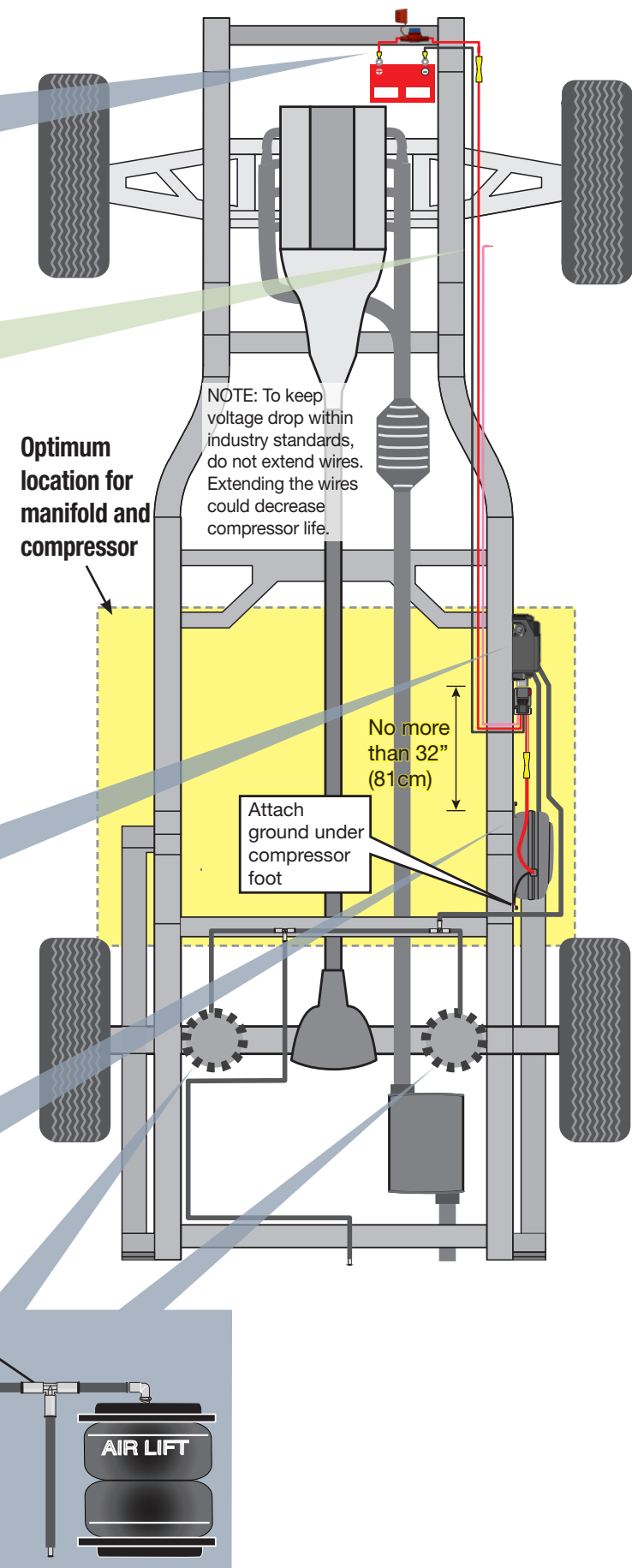

CUTTING AIR LINES

Use a sharp knife or a hose cutter and make clean, square cuts. Do not use scissors or wire cutters because these tools will deform the air line. Do not cut the lines at an angle.

The minimum bend radius for 1/4" air line is 1" (25mm). Air lines are to be installed straight into fittings.

Inspect the air line for scratches that run lengthwise. Contact Air Lift customer service if the air line is damaged.



To watch a video demonstrating proper air line cutting, go to air-lift.co/cuttingairline.



⚠ CAUTION

PLACE THE COMPONENTS AND ROUTE THE AIR LINES AND WIRING HARNESS TO AVOID HEAT SOURCES SUCH AS THE EXHAUST SYSTEM.

⚠ CAUTION

PROTECT AIR LINES AND WIRING OF ROUTING NEAR SHARP EDGES.

⚠ CAUTION

LOCATE COMPRESSOR IN AN AREA OF THE VEHICLE WHERE IT WILL BE SHIELDED FROM DIRECT SPLASH. EXCESSIVE MOISTURE CAN DAMAGE THE COMPRESSOR AND CAUSE SYSTEM FAILURE.

⚠ CAUTION

REMOVE ALL FUSES WHEN JUMP-STARTING OR WELDING ON THE VEHICLE. FAILURE TO DO SO COULD DAMAGE THE MANIFOLD.

DRILLING TEMPLATE VERIFICATION



CAUTION

IMPORTANT: PRINT THIS PAGE AT 100% SCALE. THIS IS A DRILLING TEMPLATE, WHICH WOULD BE RENDERED INCORRECT IN DIMENSION IF PRINTED WITH ANY SCALING. USING AN INCORRECT TEMPLATE TO DRILL HOLES MAY CAUSE DAMAGE TO THE

VEHICLE! PLEASE REFER TO THE ONE-INCH OR 1CM SCALES AND USE A MEASURING TOOL TO CONFIRM THAT THE PRINTED SCALE MEASURES 1" OR 1CM TO VERIFY THAT THE TEMPLATE HAS BEEN PRINTED AT 100% SCALE.

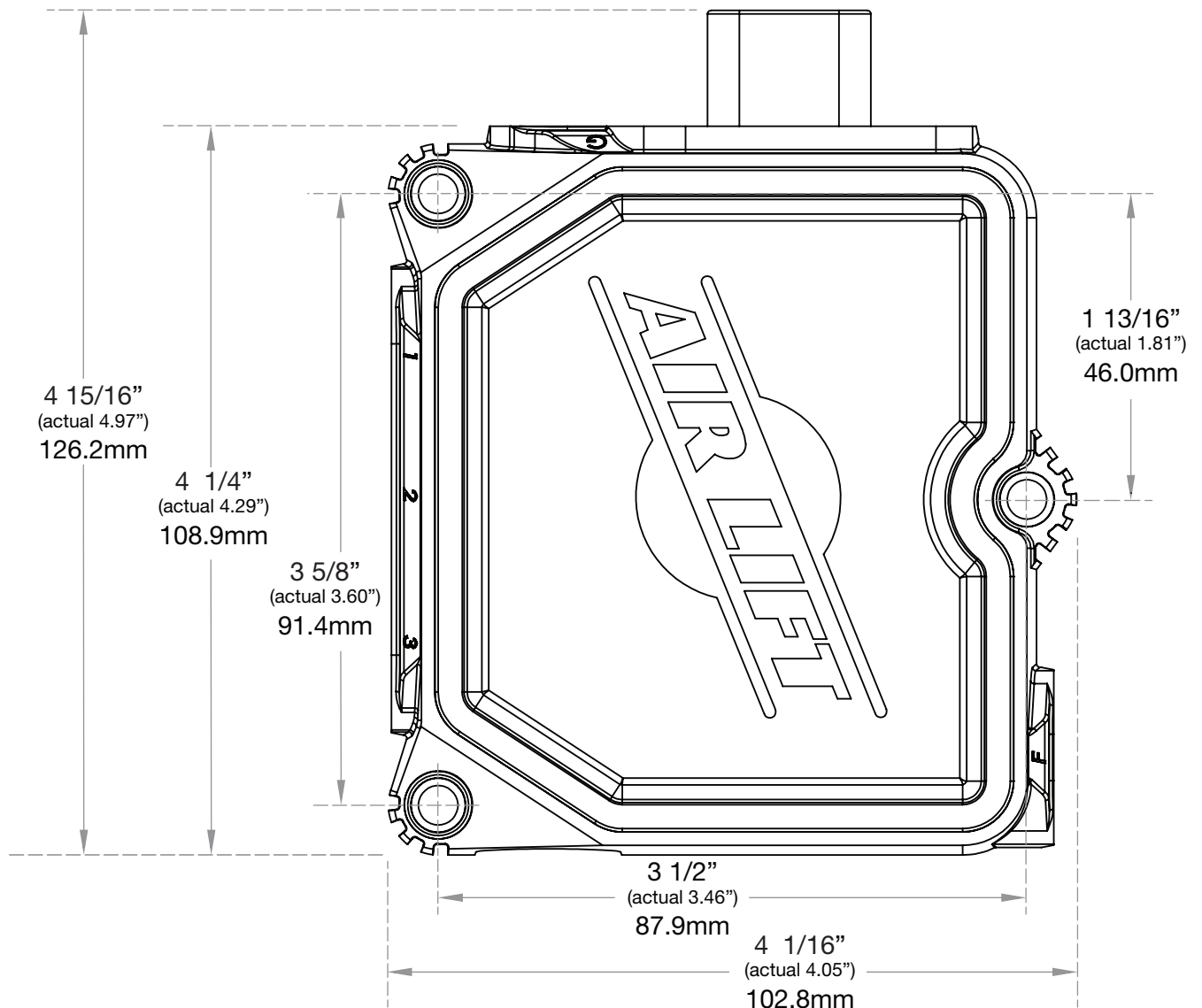

* Fractional measurements are approximate.