



CID DESIGN

SUPER RIM
TRUCK ACCESSORIES POWERED BY AIRBORNE USA

TOYOTA - TUNDRA 2015

INSTALLATION MANUAL

SPORT FENDER VENTS SET TUNDRA 2015

PART #: 1128NZZJTO01A22

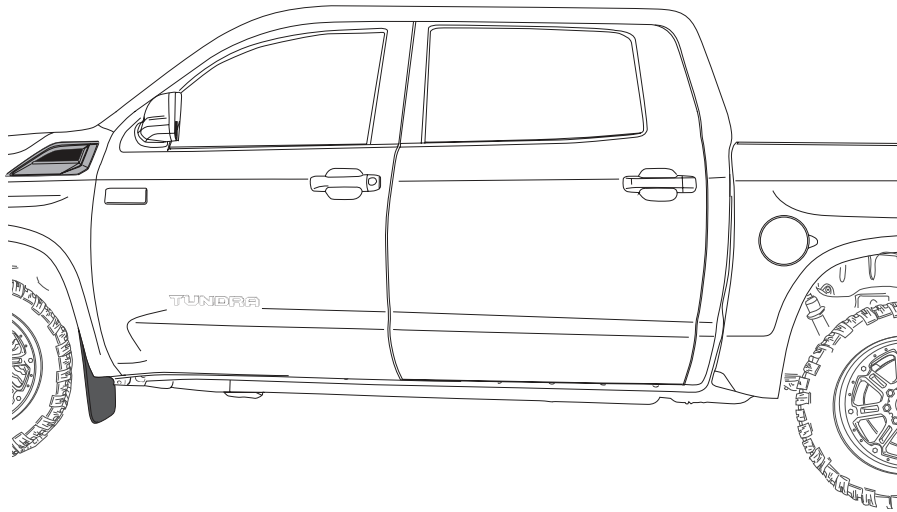

**READ CAREFULLY BEFORE
INSTALLATION**



We recommend 2 persons for installation

**DO NOT
WASH CAR**



**DRIVE SLOWLY
25 mph max**

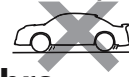





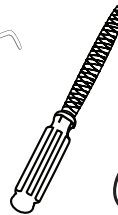
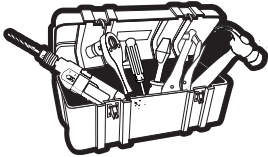

24 hrs

TOOLS

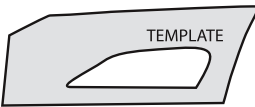

CHECK LIST

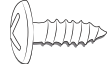
*Already installed in the part

ITEM	DESCRIPTION	DRAWING	AMOUNT
A	* VHB TAPE		Included in the parts
B	GREASE PENCIL	 GREASE PENCIL	1 pc
C	AUTOMOTIVE ADHESION PROMOTER		1 pc
D	TEMPLATE	 TEMPLATE	Included
E	* GRILL		2 pcs
F	* TIN SCREW 5/32" X 3/8"		8 pcs
G	* WASHER 5/32"		8 pcs
H	ECO DOME		1 pc



CID DESIGN

SUPER RIM
TRUCK ACCESSORIES POWERED BY HUNTERDUN USA

TOYOTA - TUNDRA 2015

INSTALLATION MANUAL

! WASH WITH WATER, DETERGENT AND SOFT CLOTH OR SPONGE

1 GRILL MOUNT

INSTALL THE GRILL IF NEEDED

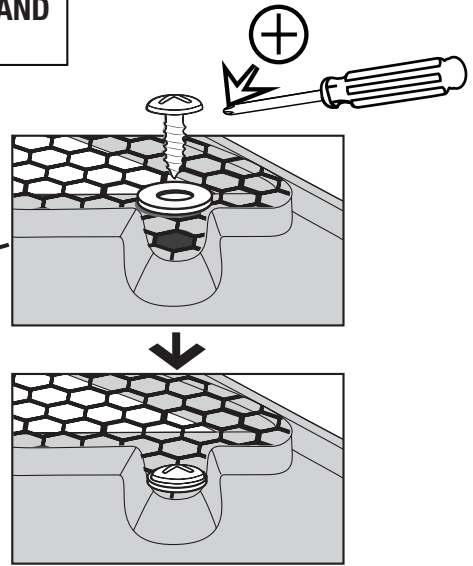
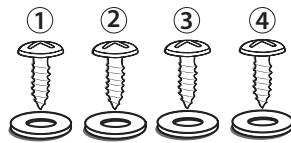
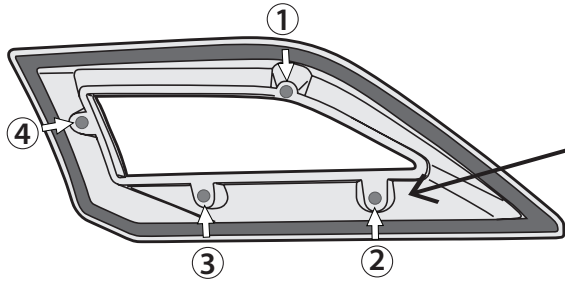

2 PLACE TEMPLATE

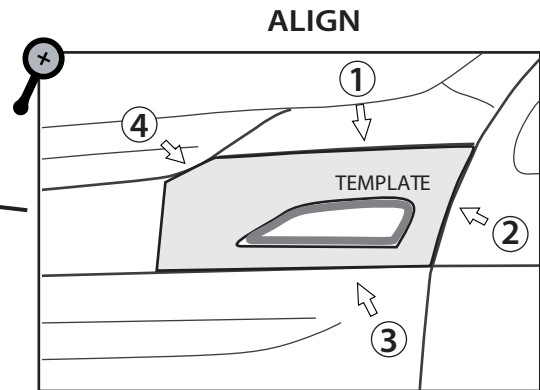
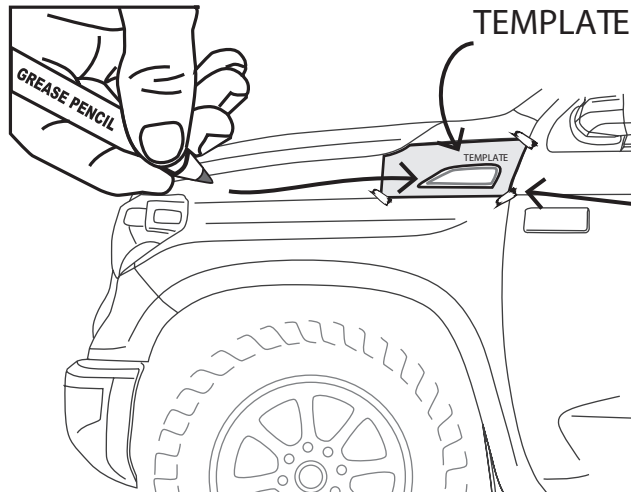

3 OUTLINE OUTER CONTOUR WITH MASKING TAPE

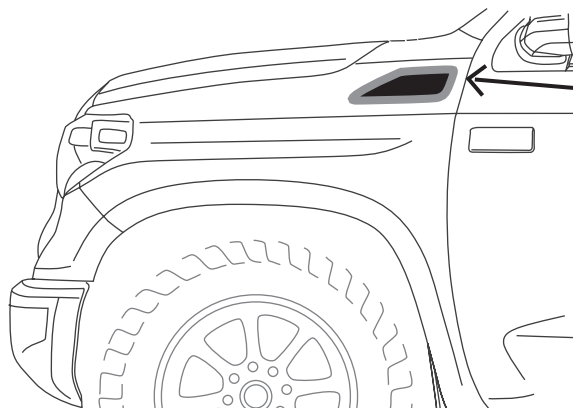



CID DESIGN

SUPER RIM
TRUCK ACCESSORIES POWERED BY KIMBERLY USA

TOYOTA - TUNDRA 2015

INSTALLATION MANUAL

4 CUT

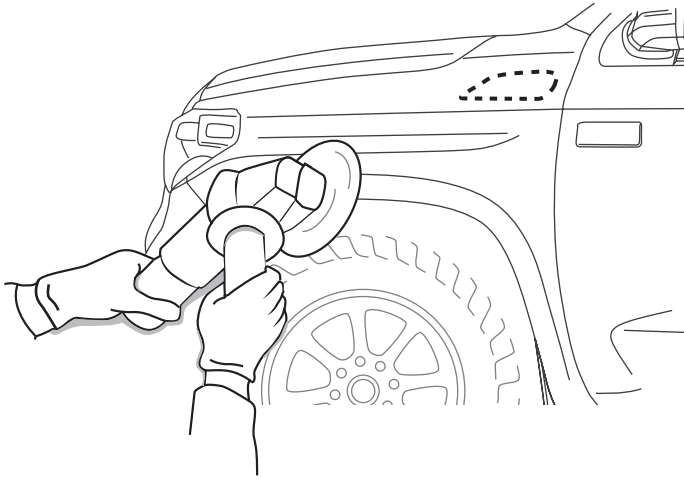

CAUTION

PERSONAL
PROTECTIVE EQUIPMENT
REQUIRED

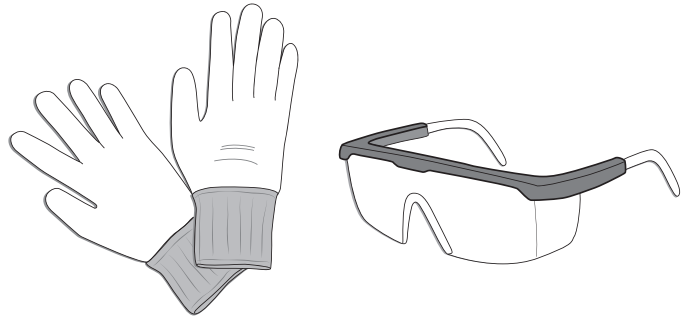

5 FILE DOWN THE EDGE

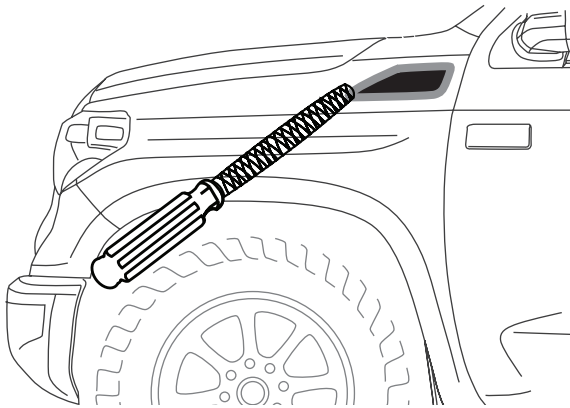

6 CLEAN

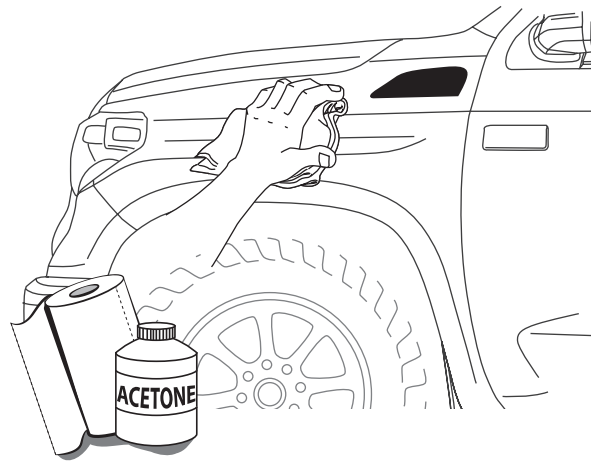

7 CORROSION PROTECTION

APPLY ON THE EDGE OF SHEET METAL

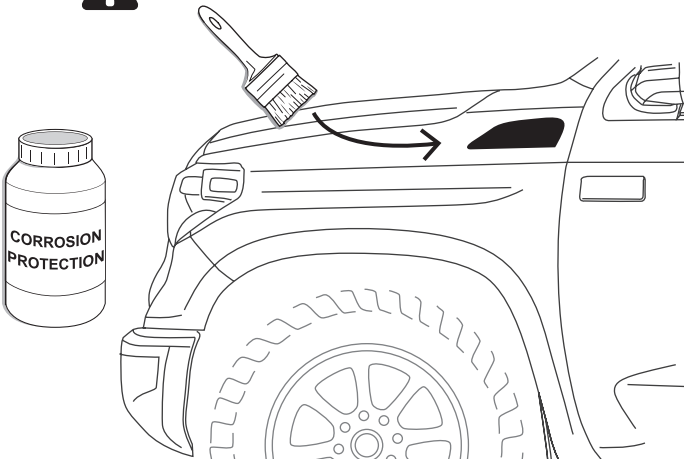

8 PRE-MOUNT

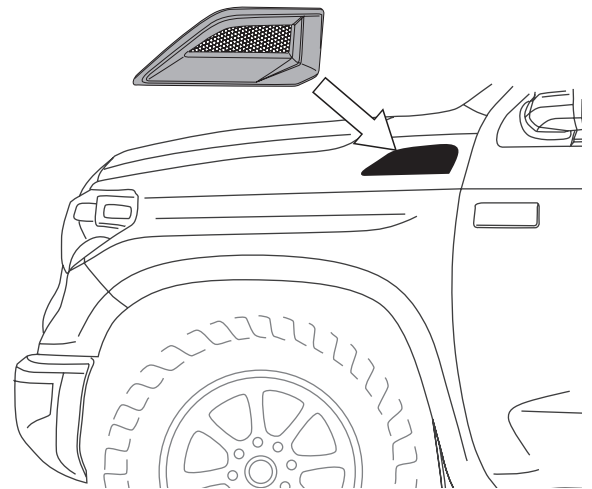



CID DESIGN

SUPER RIM
TRUCK ACCESSORIES POWERED BY HANSON USA

TOYOTA - TUNDRA 2015

INSTALLATION MANUAL

9 PAINT INTERIOR WITH BLACK PAINT

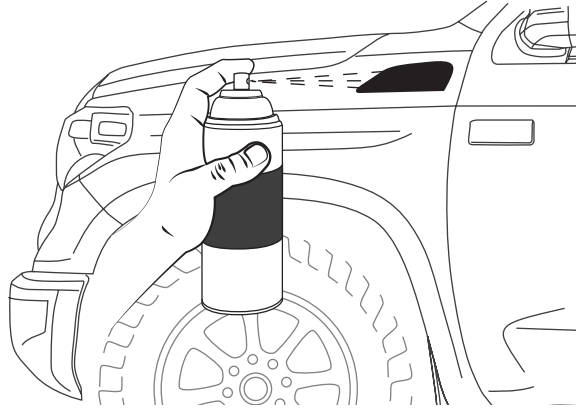

10 ALIGN

! ALIGN TO THE EDGE OF THE DOOR WITH 1/4" MASKING TAPE.

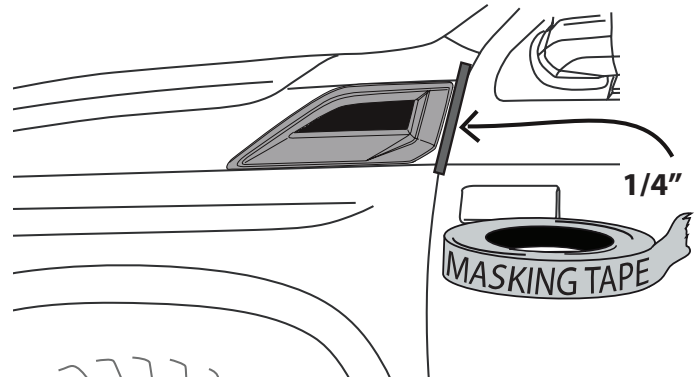

11 MARK

! HASH MARKS

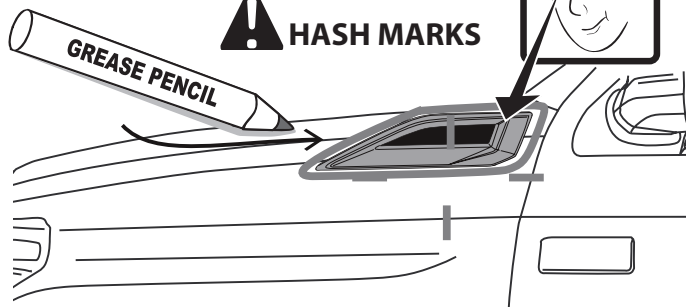

12 ADHESION PROMOTER

! FIRST CLEAN ALL OVER THE APPLICATION AREA WITH ACETONE

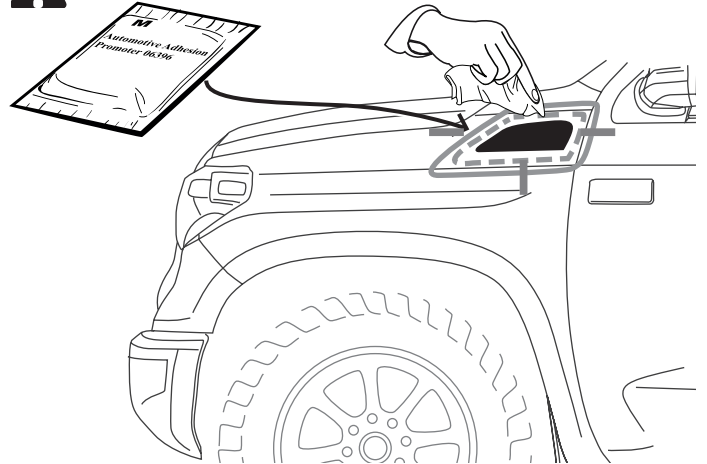

DRAW CENTER HASH MARK WITH GREASE PENCIL ON FENDER VENTS AND SHEET METAL, THIS WILL ENSURE FENDER VENTS BE CENTERED TO GREASE PENCIL OUTLINE.

13 PEEL

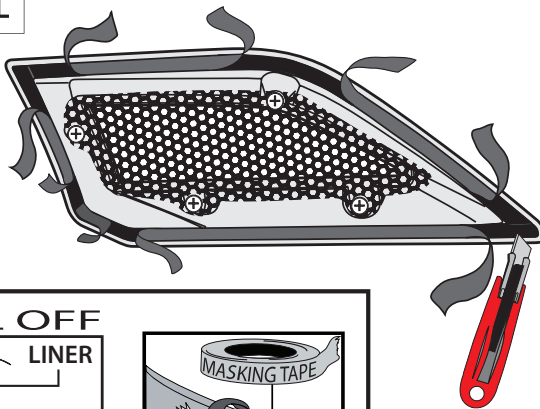

! WARM SURFACES WITH HEAT GUN IF SURFACE TEMPERATURE IS TOO COLD.

PEEL OFF

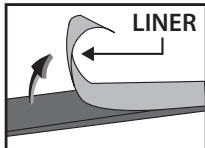

Hold the liner out

A full surface contact between tape and substrate is decisive for good adhesion performance. Contact is achieved by applying pressure. In practice a pressure between 40 and 50 N/cm² is usually needed and an application temperature between 25 and 45 °C or 77 and 113 °F is also necessary. During application, add-on parts and tapes must have the similar temperature.



CID DESIGN

SUPER RIM
TRUCK ACCESSORIES POWERED BY AIRBORNE USA

TOYOTA - TUNDRA 2015

INSTALLATION MANUAL

14 PLACE

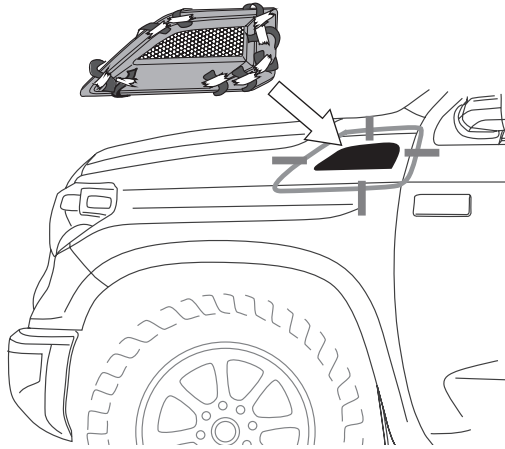

15 REMOVE LINER

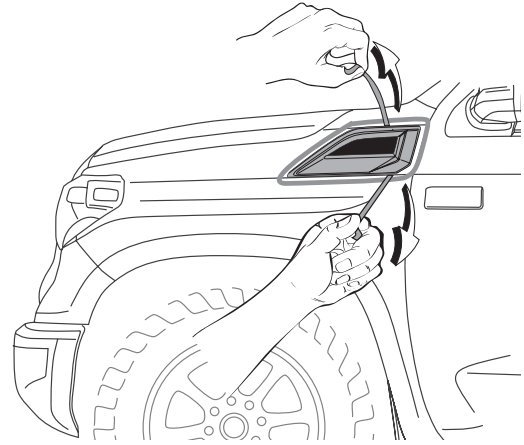

16 PRESS

APPLY PRESSURE

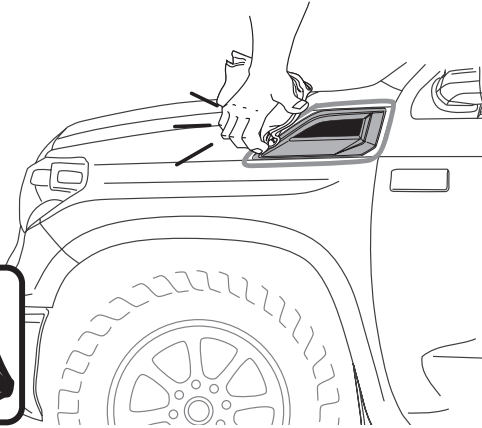

40-50 N/cm²

17 CLEAN OFF GREASE PENCIL MARK

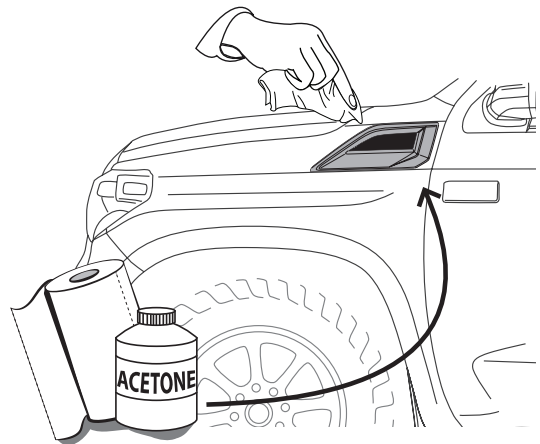

INSTALLED PARTS

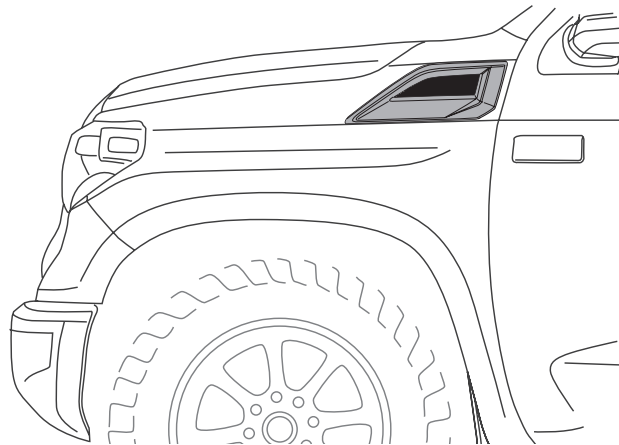

**TOYOTA TUNDRA
FENDER VENT
CUT TEMPLATE**

LH

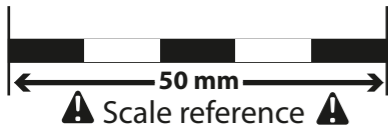

REFERENCE LINE

BONDING AREA

BONDING AREA

CUT AREA

BONDING AREA

BONDING AREA

DOOR EDGE CLEARANCE 1/4"

DOOR

REFERENCE LINE

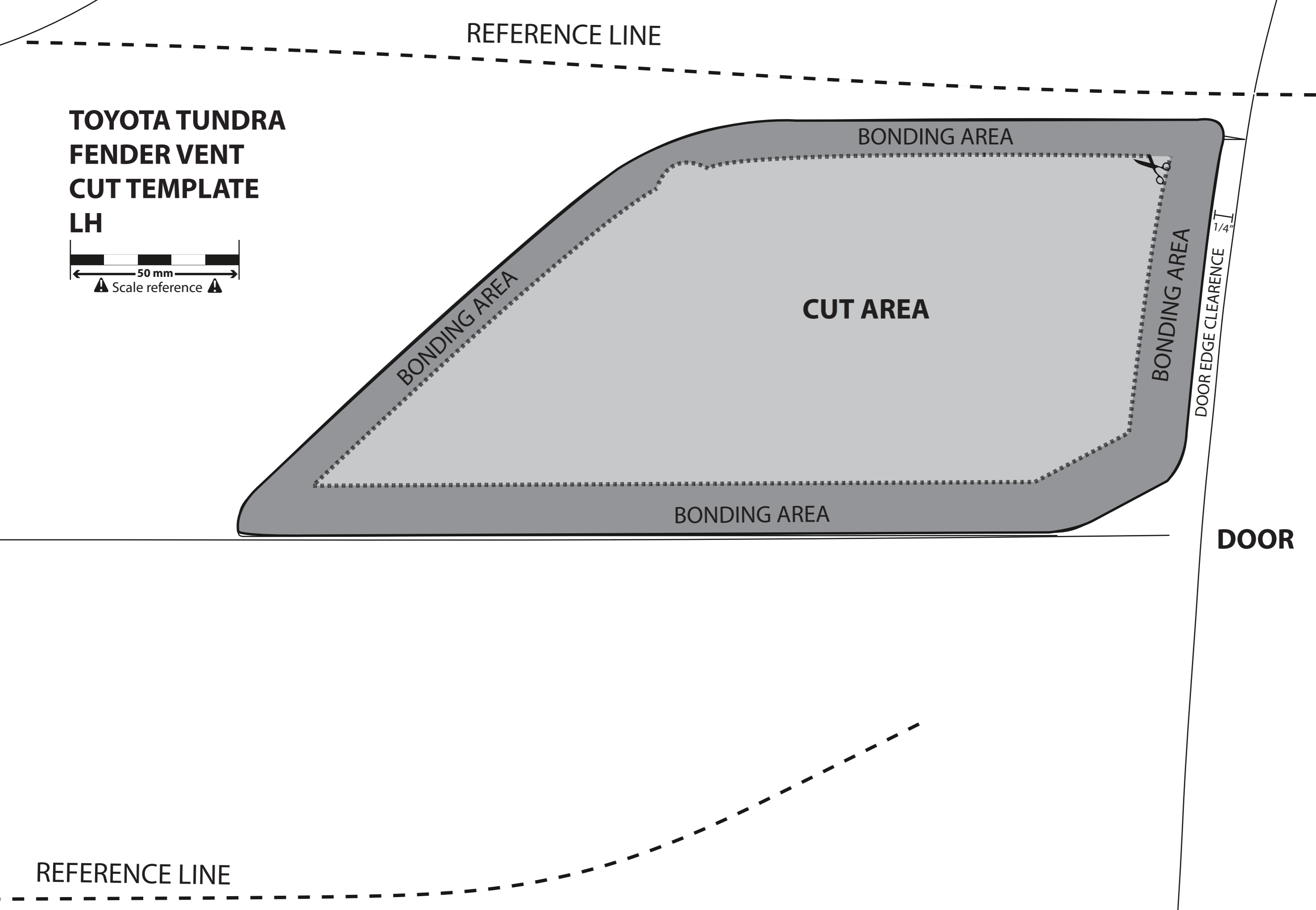

REFERENCE LINE

TOYOTA TUNDRA FENDER VENT CUT TEMPLATE RH

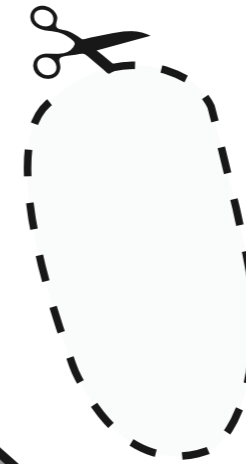
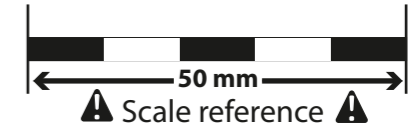

BONDING AREA

CUT AREA

BONDING AREA

BONDING AREA

BONDING AREA

DOOR EDGE CLEARANCE
1/4"

DOOR

Learn more about chrome trim on our website.

REFERENCE LINE