

INSTALLATION MANUAL

SUPER-BOLT FENDER FLARES SET SIERRA 2016 SHORT / LONG BOX

PART # : GM28D05 / GM28D11



**READ CAREFULLY
BEFORE INSTALLATION**



**WASH & CLEAN
PROPERLY BEFORE
INSTALLING**

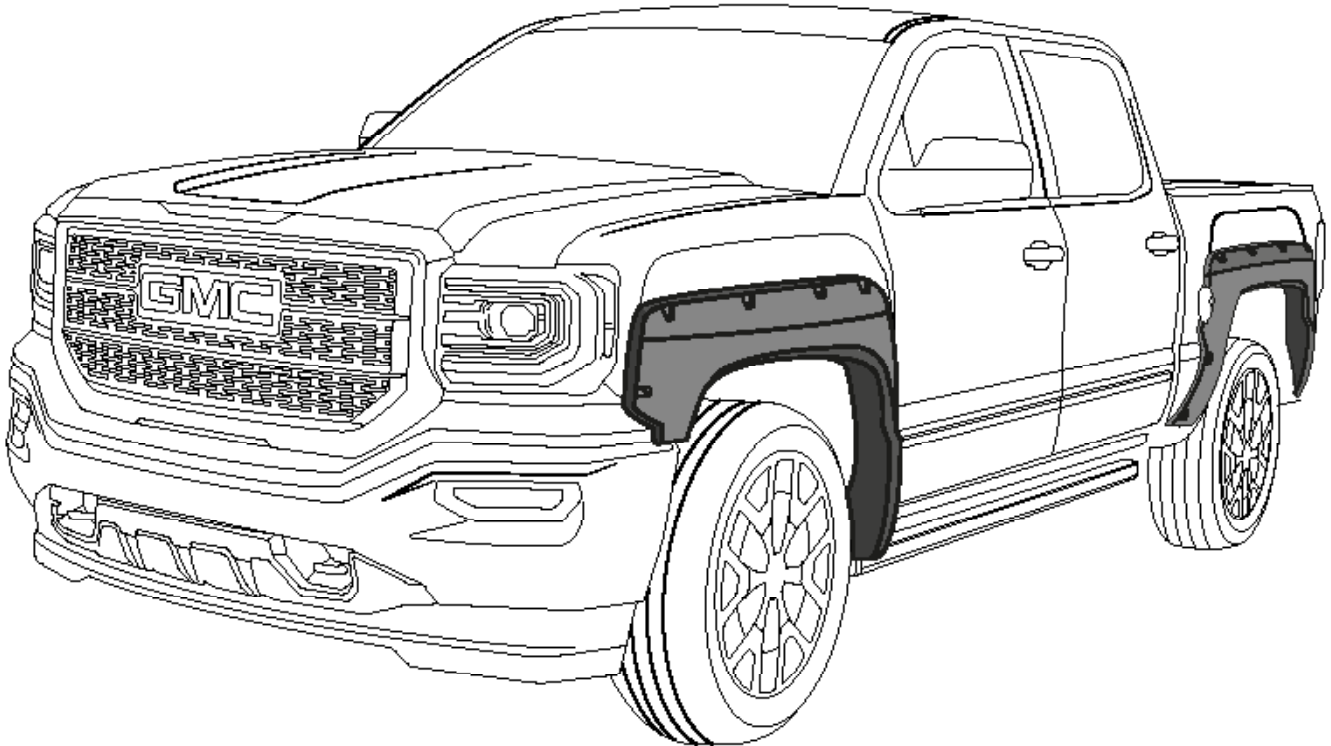

**WE RECOMMEND
2 PERSON
INSTALLATION**

AFTER INSTALLING

DO NOT WASH CAR





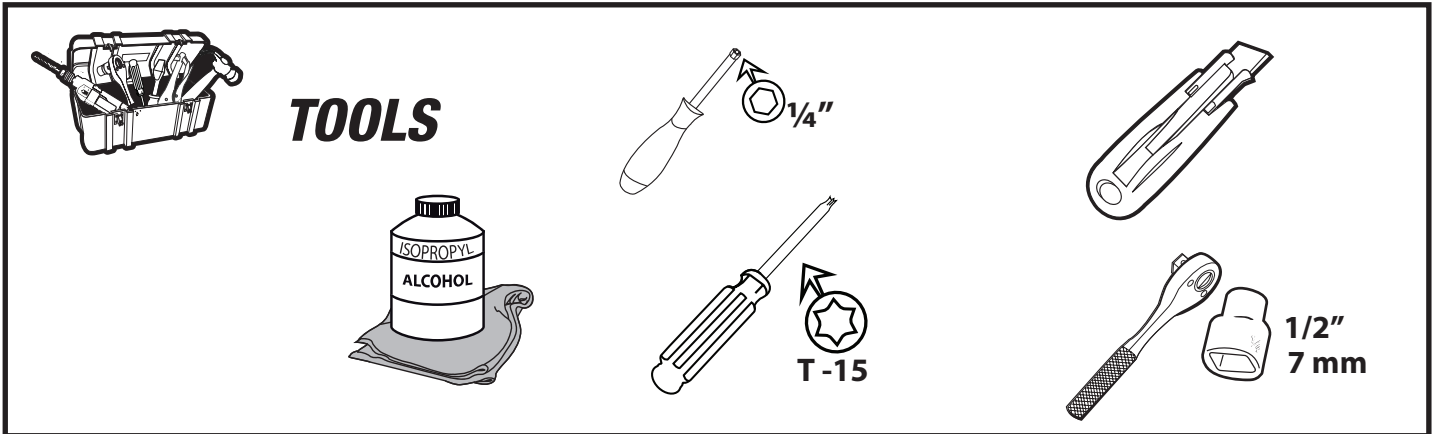







48 hrs



CHECK LIST

*Already installed in the part

ITEM	DESCRIPTION	DRAWING	AMOUNT
A	*SUPER BOLT'S RUBBER STUDS		36 pcs
B	*STAINLESS SUPER BOLT M6X14.87		36 pc
C	PVC TRIM		33 ft
D	AUTOMOTIVE ADHESION PROMOTER TESA #60153		1 pc
E	APPLICATION SPONGE		1 pc
F	GREASE PENCIL		1 pc
G	U-CLIP		8 pcs
H	PUSH PIN 46		2 pcs
I	THREADLOCKER 222		1 pc
J	STAINLESS STEEL SUPPORT		2 pcs
K	SUPER BOLT PRESSING TOOL		1 pc

INSTALLATION MANUAL

FRONT RIGHT & LEFT FLARE

1 REMOVE SCREWS

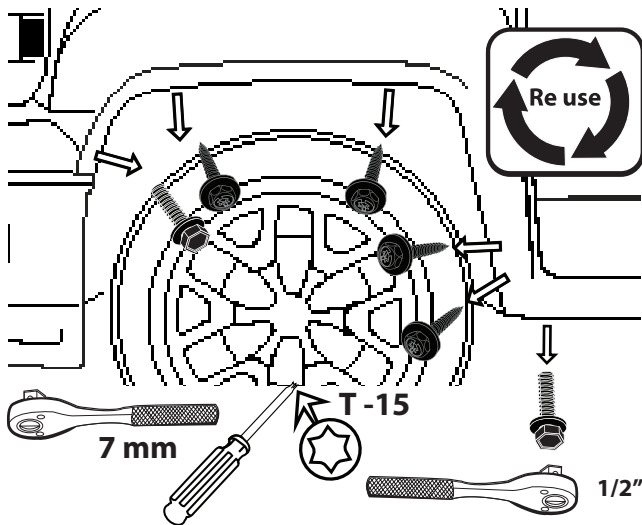

3 PLACE STAINLESS STEEL SUPPORT

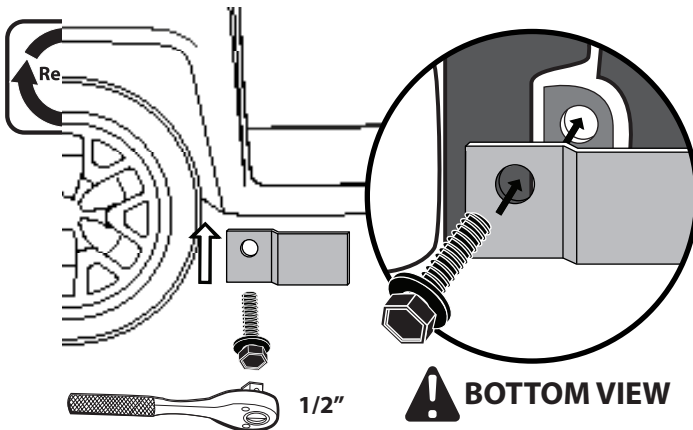

5 SECURE THE PART

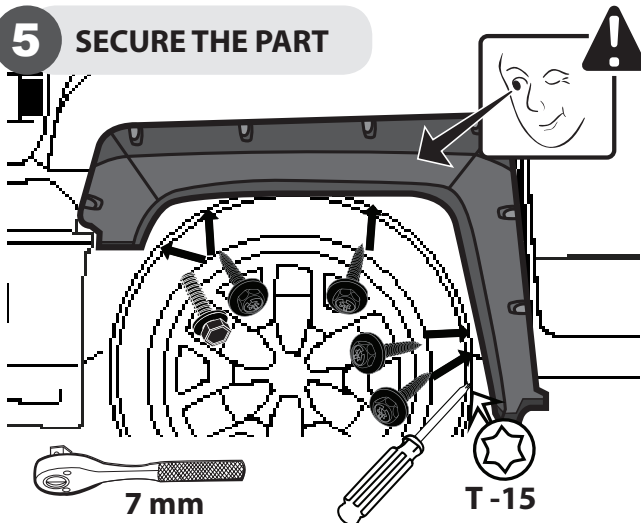

2 CLEAN

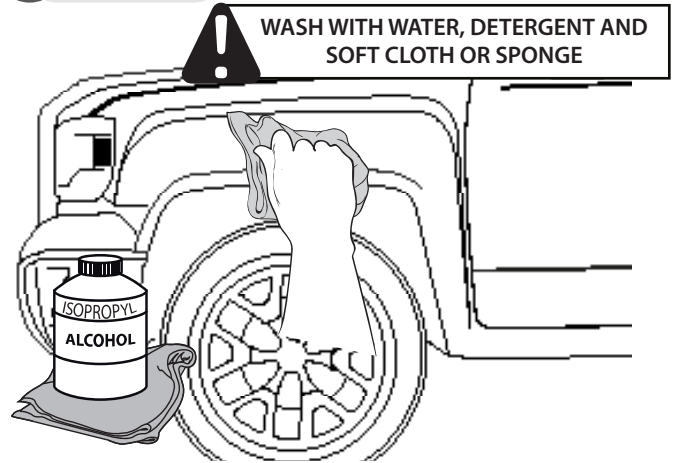

4 PRE-MOUNT

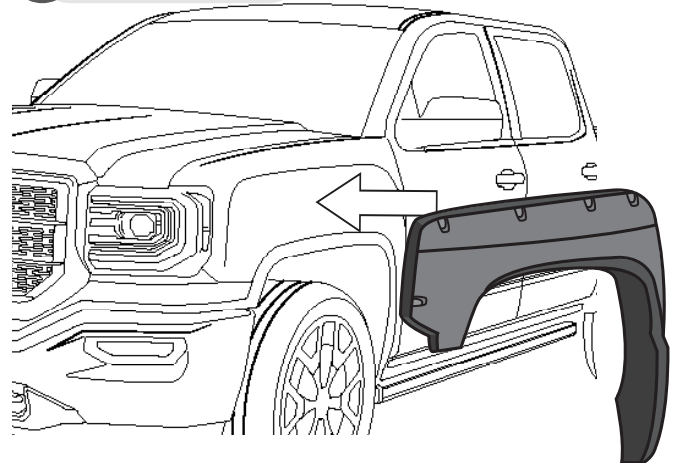

6 MARK SILHOUETTE AND SUPER BOLTS POSITIONS

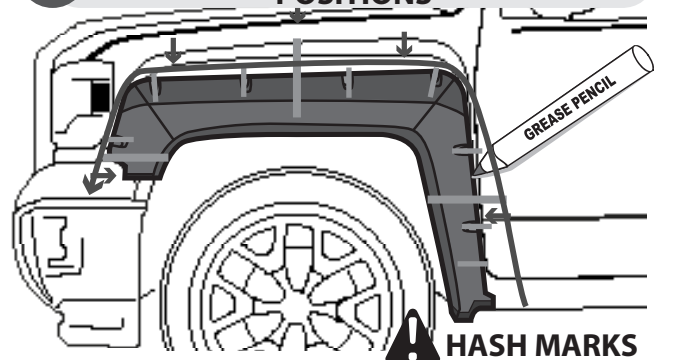

DRAW CENTER HASH MARK WITH GREASE PENCIL AT CENTER, BOTH SIDES, ON EACH SUPER BOLT AND SHEET METAL. THIS WILL ENSURE WHEEL FLARE WILL BE CENTERED TO GREASE PENCIL OUTLINE.

INSTALLATION MANUAL

7 UNSCREW & REMOVE

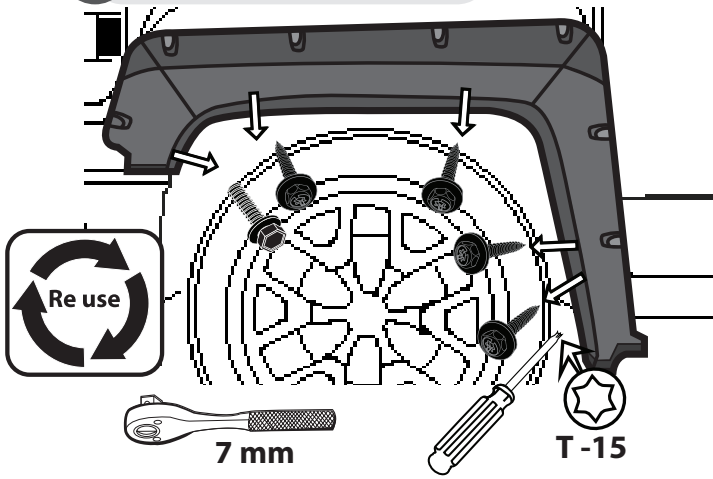

8 CLEAN

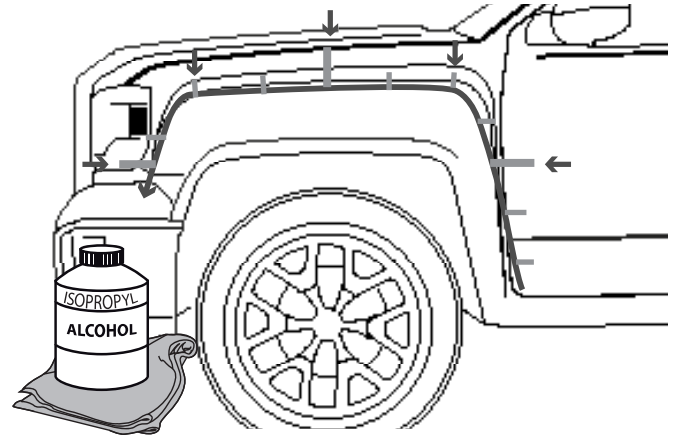

9 ADHESION PROMOTER APPLICATION AREA

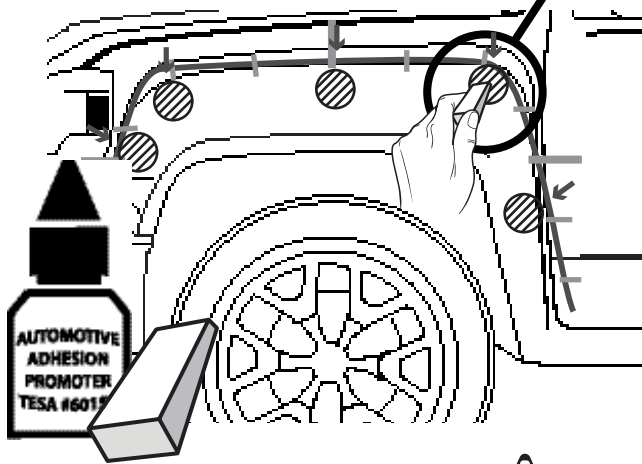

10 REMOVE LINER

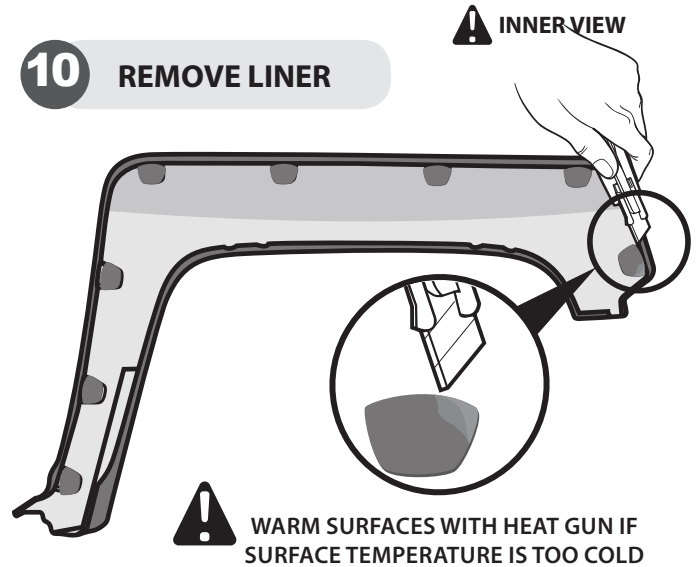

11 PRE-MOUNT

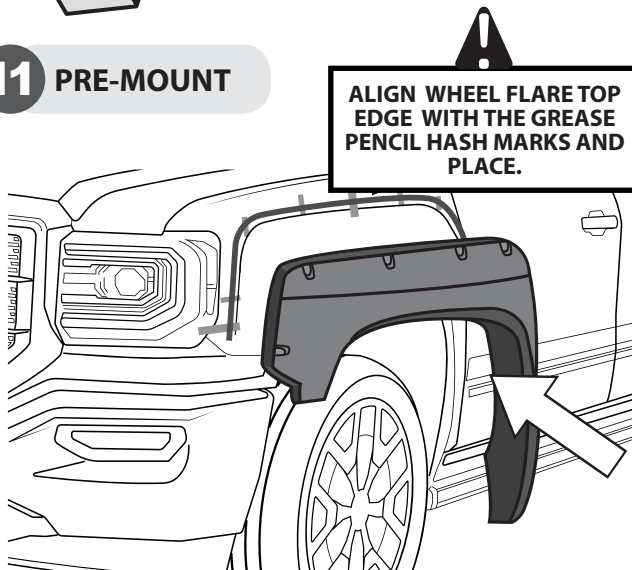

12 SECURE THE PART

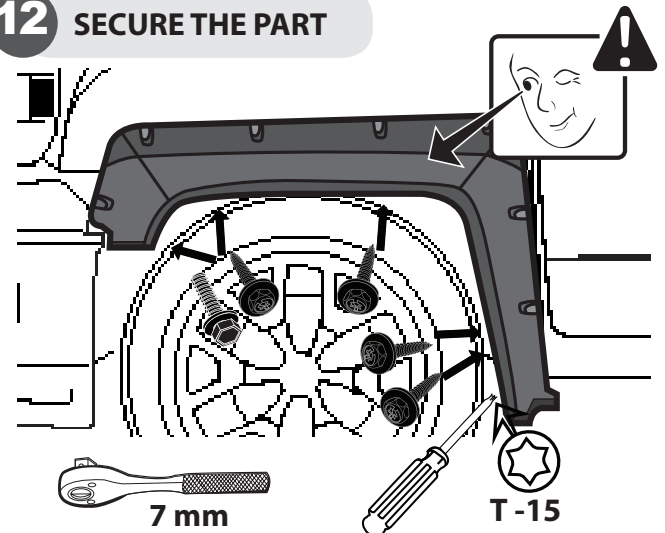

INSTALLATION MANUAL

13 APPLY PRESSURE ON EACH SUPER BOLT

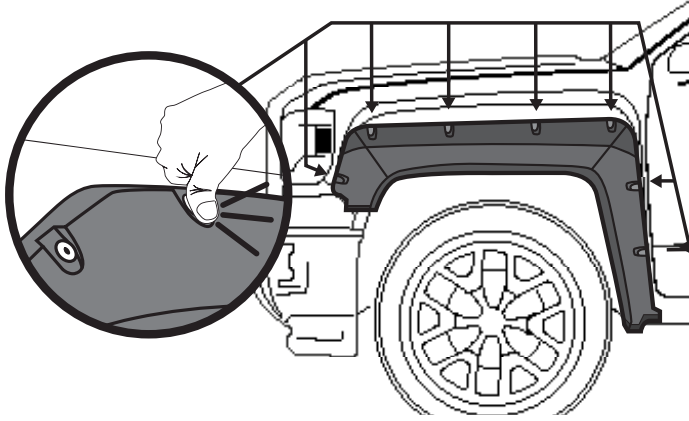

14 UNSCREW

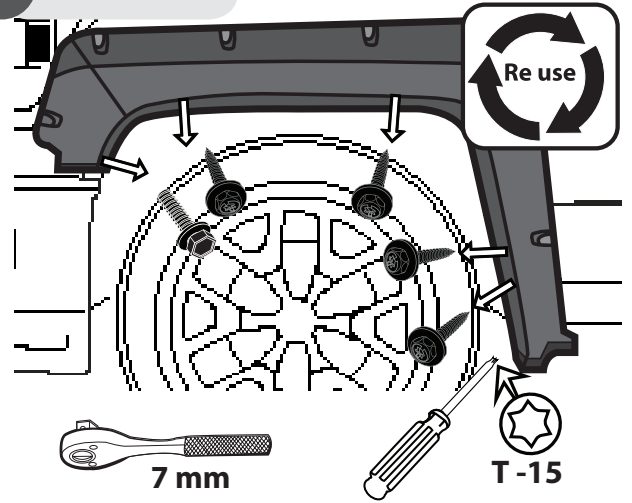

15 REMOVE SUPER BOLTS

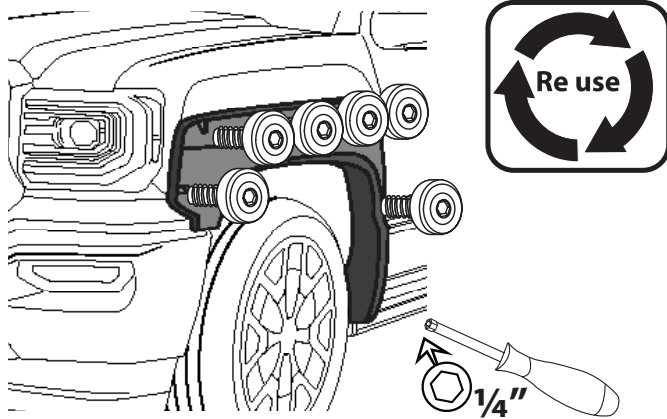

16 REMOVE

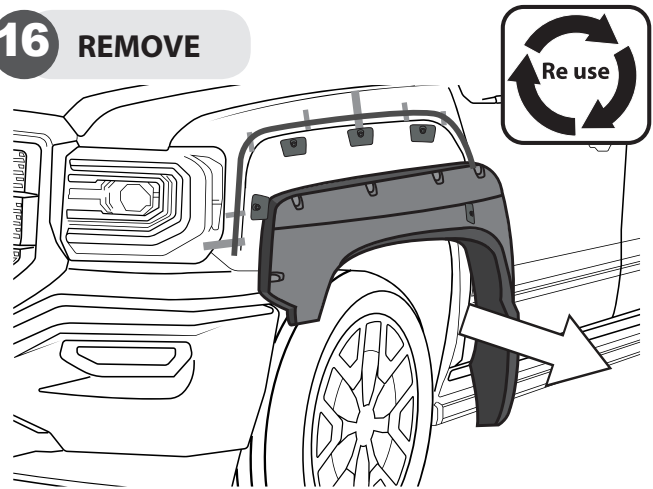

SUPER BOLT INSTALLATION

17 PRESS SUPER BOLTS STUDS

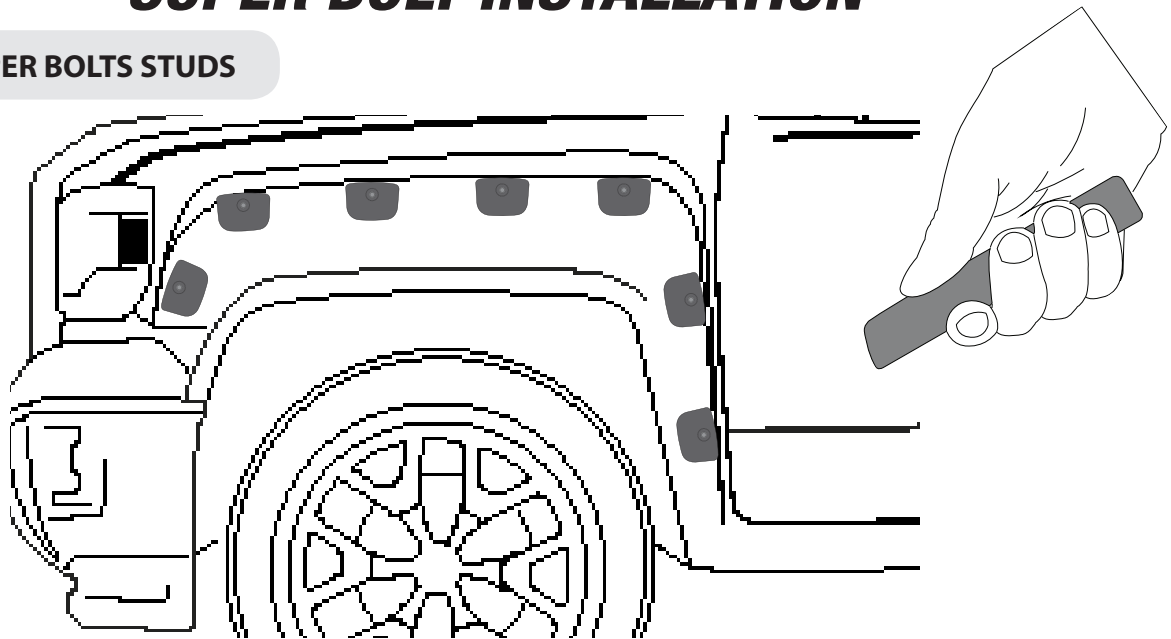

FOR GOOD ADHESION IT IS NECESSARY TO APPLY AS MUCH PRESSURE AS POSSIBLE ALL OVER THE EDGE AND CENTER OF THE SUPER BOLTS STUDS.



40-50 N/cm

SUPER BOLT STUDS

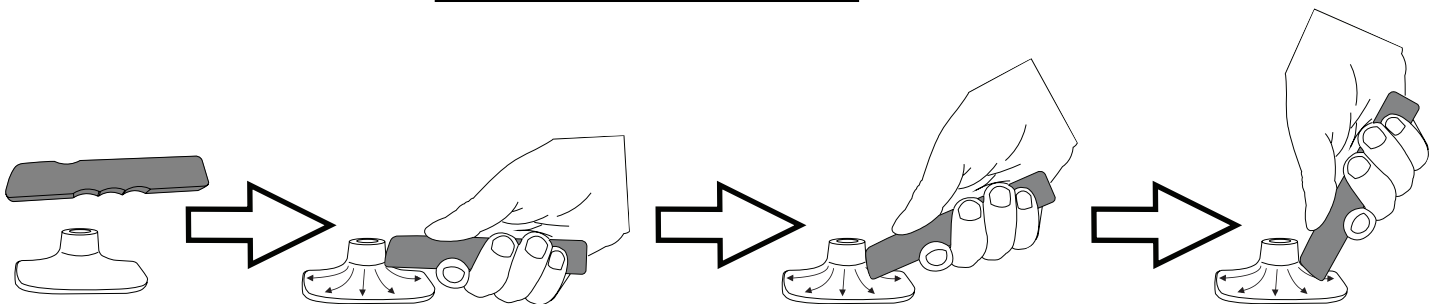

PRESSURE POINTS

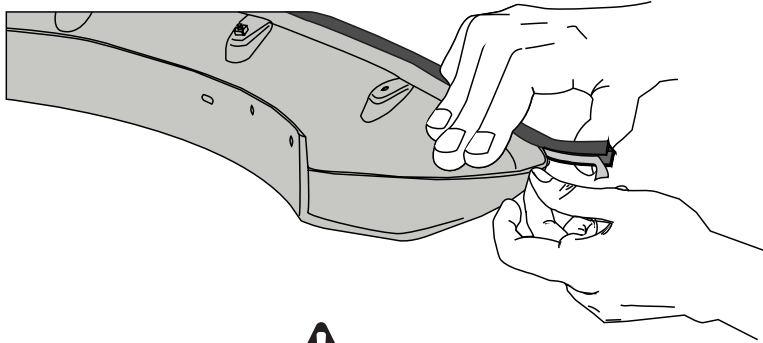

A full surface contact between tape and substrate is important for good adhesion performance. Contact is achieved by applying pressure. In practice a pressure between 40 and 50 N/cm² is usually needed and an application temperature between 25 and 45 °C or 77 and 113 °F is also necessary. During application, add-on parts and tapes must have the similar temperature.

INSTALLATION MANUAL
18 PLACE PVC TRIM

! INNER VIEW

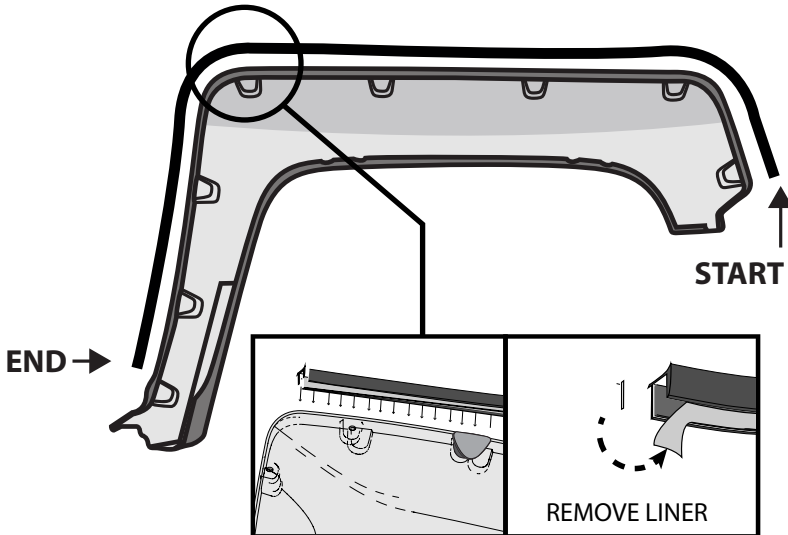
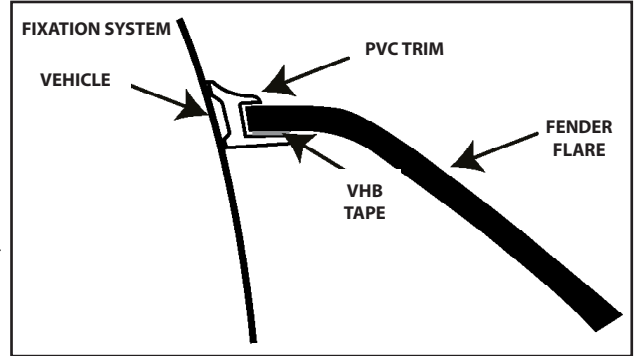
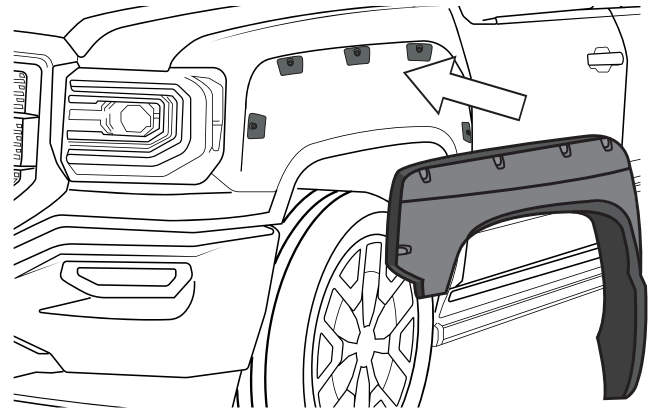

19 PLACE

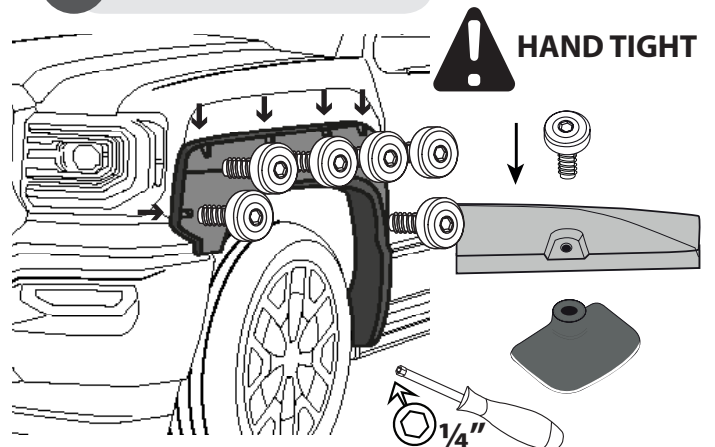
20 APPLY LOCTITE THREADLOCKER TO SUPER BOLT'S THREAD

!
ATTENTION

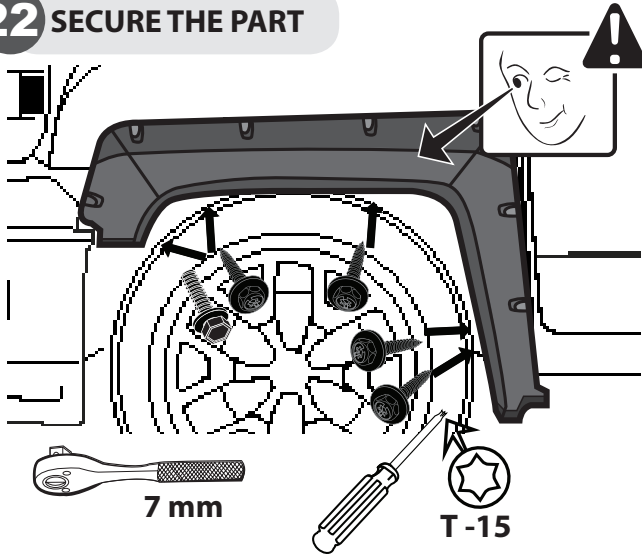

21 PLACE SUPER BOLTS

INSTALLATION MANUAL

22 SECURE THE PART

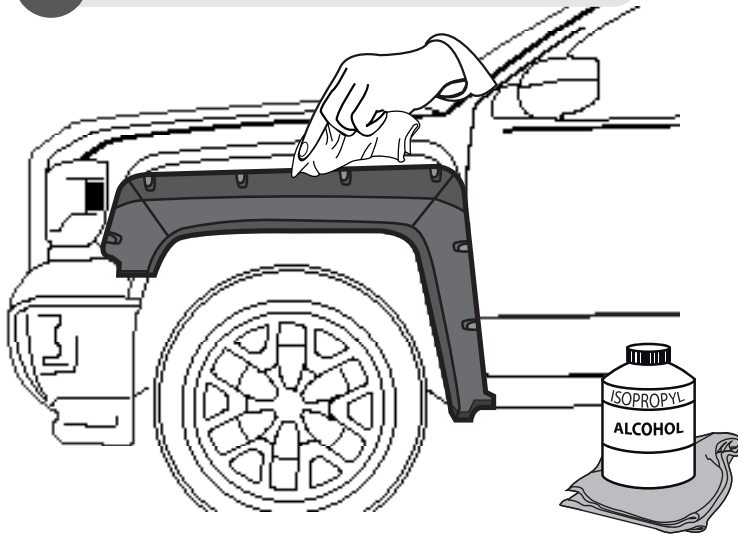

24 CLEAN OFF GREASE PENCIL MARK



23 PLACE U-CLIP

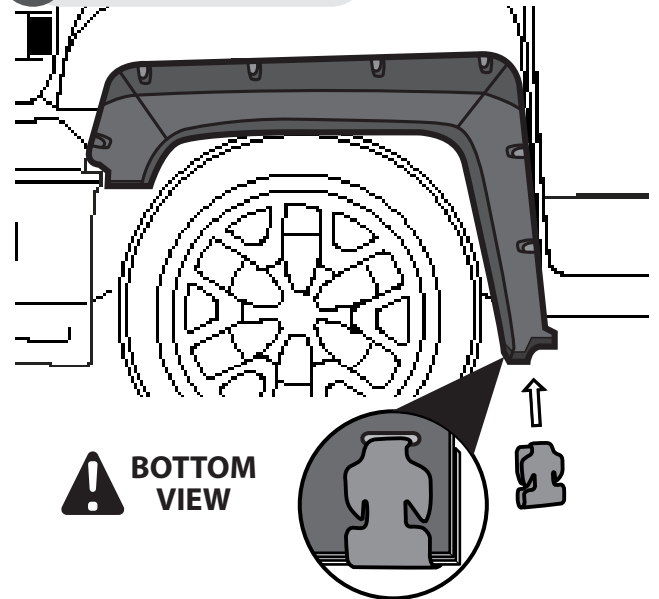

! PLACE THE U-CLIP TO HOLD TOGETHER THE PREVIOUSLY INSTALLED STAINLESS STEEL SUPPORT AND THE FENDER FLARE

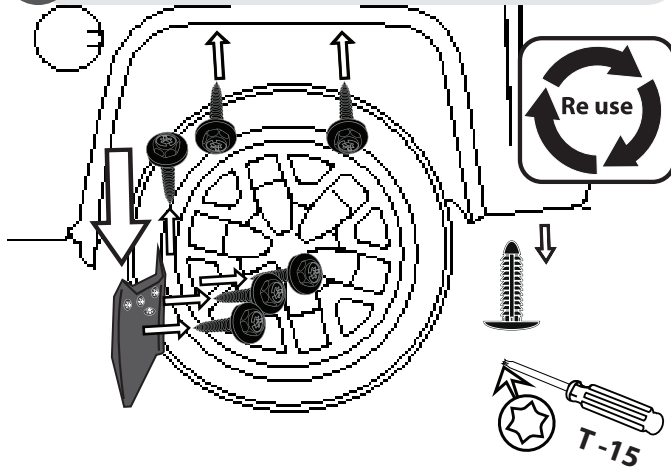
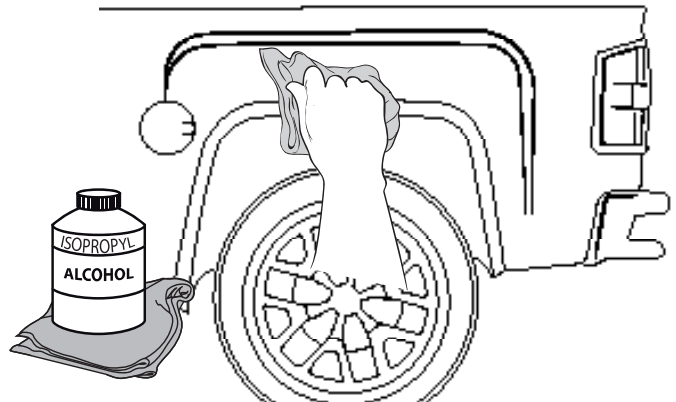
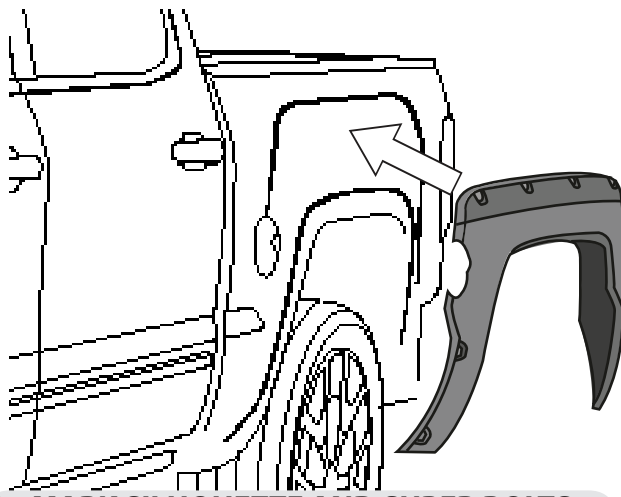
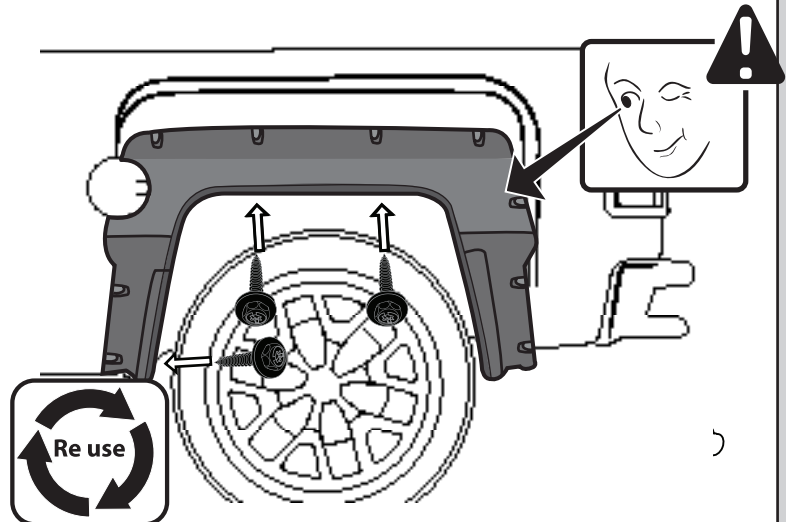
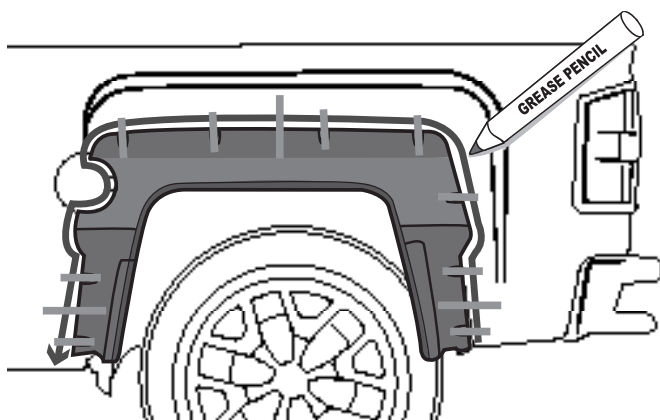
INSTALLATION MANUAL
REAR RIGHT & LEFT FLARE
1 REMOVE SCREWS AND MUD GUARD

2 CLEAN

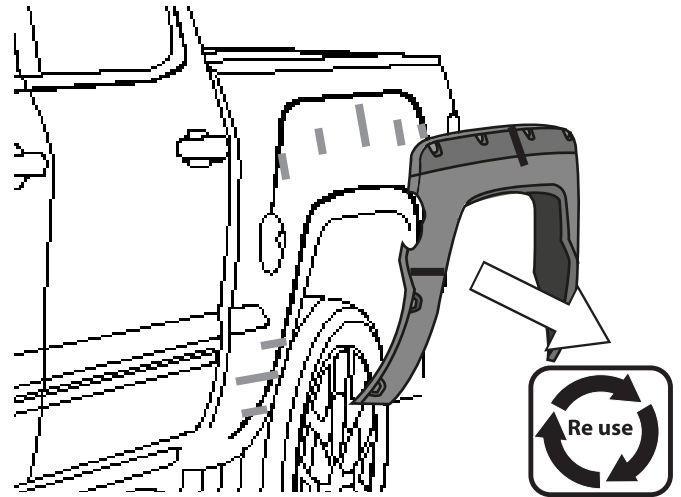
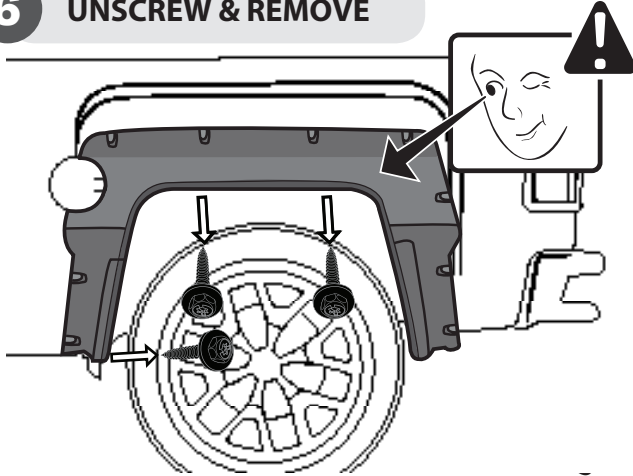
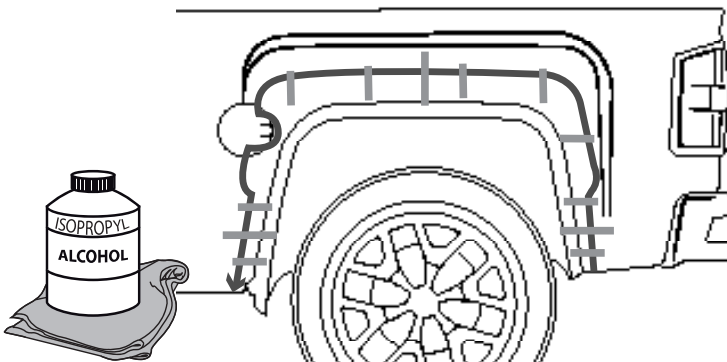
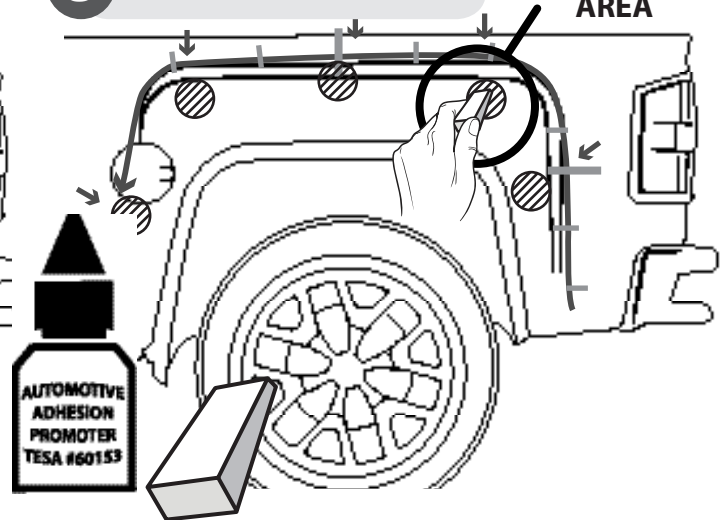
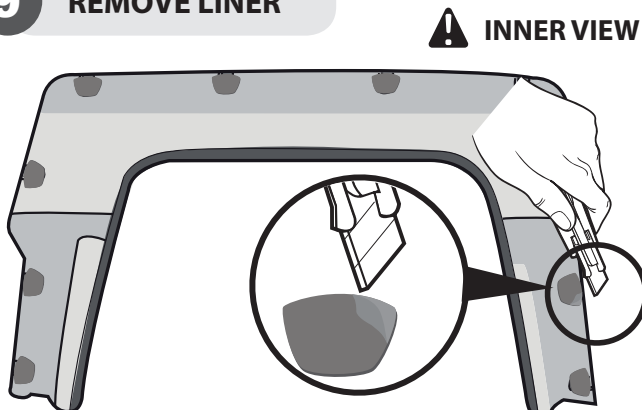
3 PRE-MOUNT

4 SECURE THE PART

5 MARK SILHOUETTE AND SUPER BOLTS POSITIONS

HASH MARKS

DRAW CENTER HASH MARK WITH GREASE PENCIL AT CENTER, BOTH SIDES, ON EACH SUPER BOLT AND SHEET METAL. THIS WILL ENSURE WHEEL FLARE WILL BE CENTERED TO GREASE PENCIL OUTLINE.

INSTALLATION MANUAL
6 UNSCREW & REMOVE

7 CLEAN

8 ADHESION PROMOTER

9 REMOVE LINER

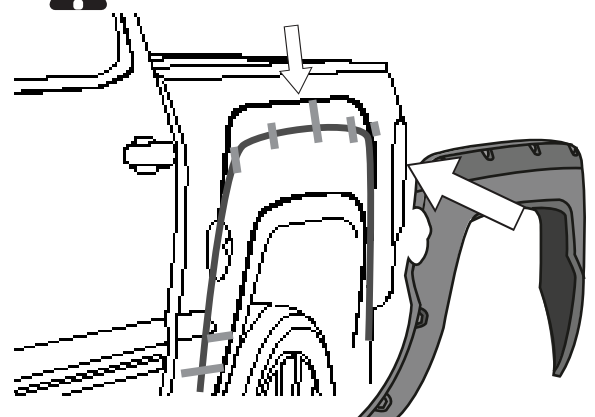

 WARM SURFACES WITH HEAT GUN IF SURFACE TEMPERATURE IS TOO COLD

10 PRE-MOUNT

 ALIGN WHEEL FLARE TOP EDGE WITH THE GREASE PENCIL HASH MARKS AND PLACE.



INSTALLATION MANUAL

11 SECURE THE PART

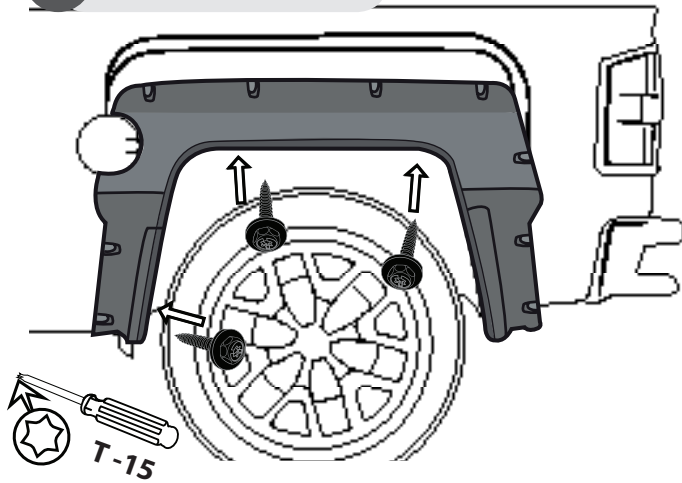

12 APPLY PRESSURE ON EACH SUPER BOLT

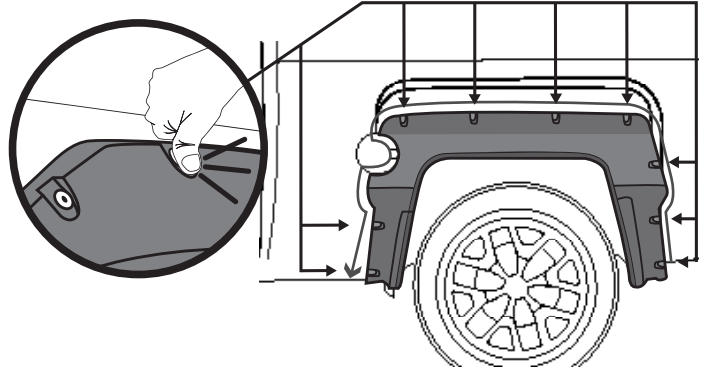

13 UNSCREW

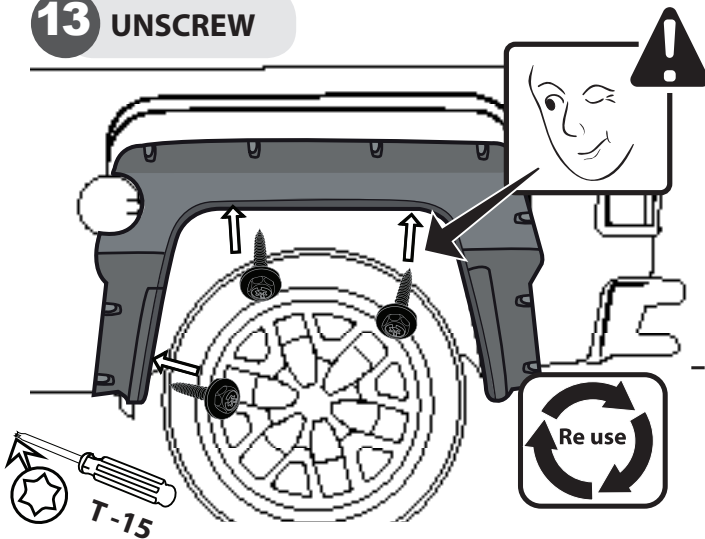

14 REMOVE SUPER BOLTS

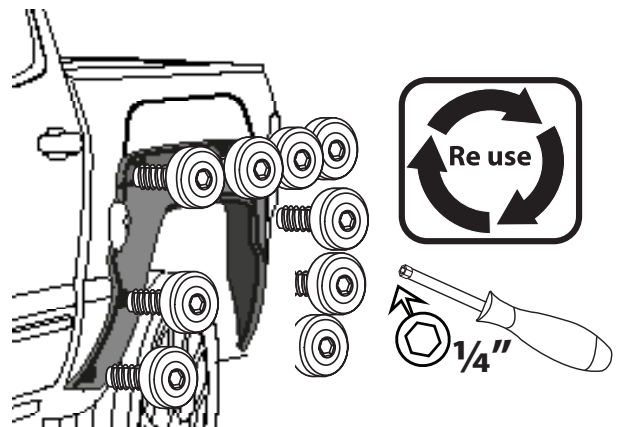

15 REMOVE



SUPER BOLT INSTALLATION

16 PRESS SUPER BOLTS STUDS

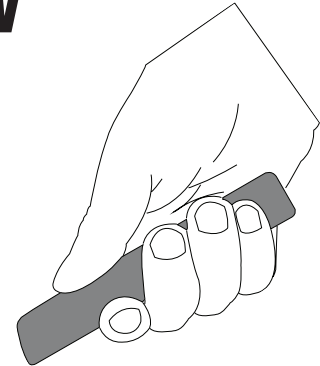
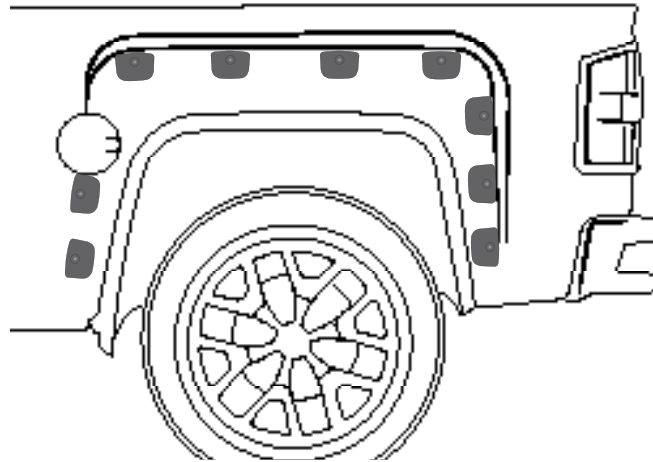

FOR GOOD ADHESION IT IS NECESSARY TO APPLY AS MUCH PRESSURE AS POSSIBLE ALL OVER THE EDGE AND CENTER OF THE SUPER BOLTS STUDS.



40-50 N/cm

SUPER BOLT STUDS

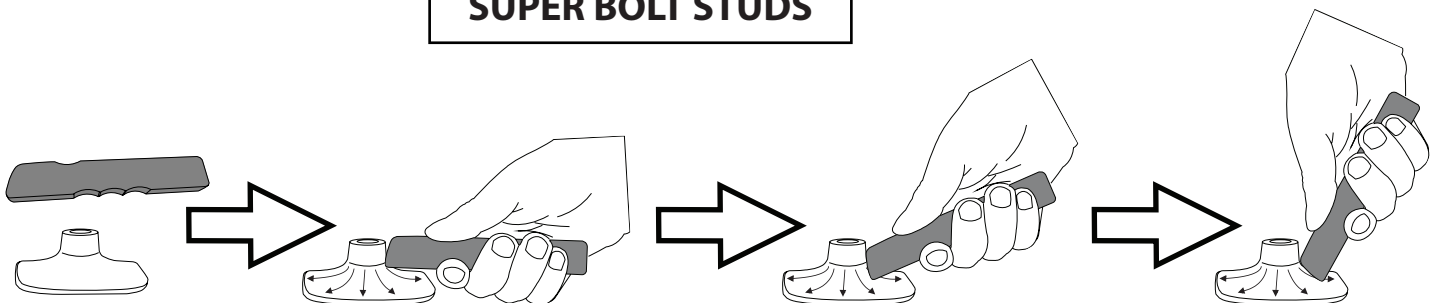

PRESSURE POINTS

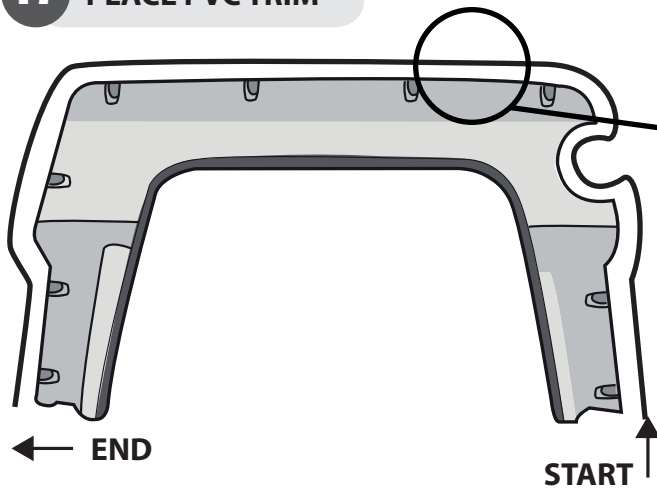
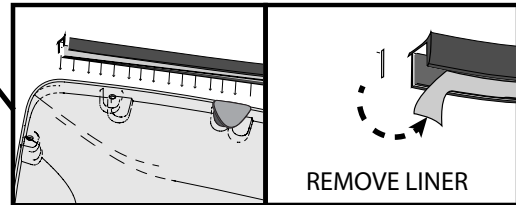
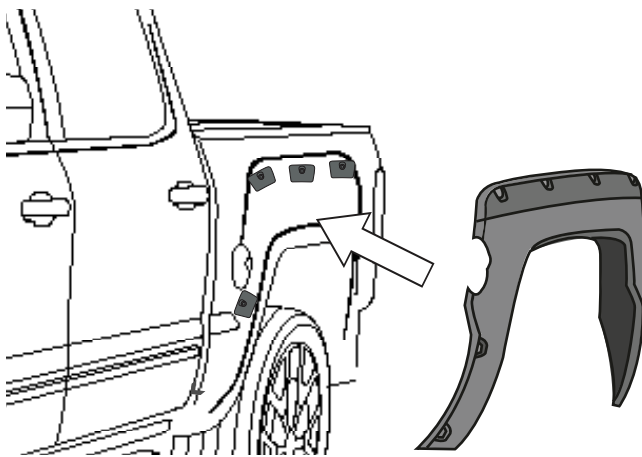
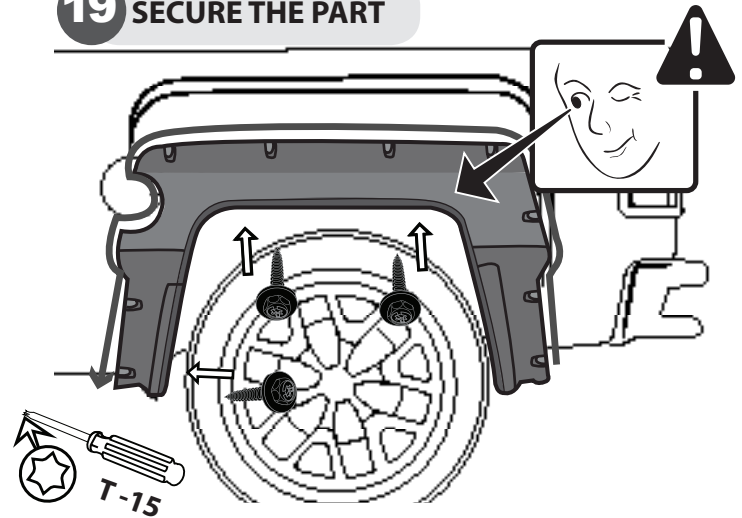

A full surface contact between tape and substrate is important for good adhesion performance. Contact is achieved by applying pressure. In practice a pressure between 40 and 50 N/cm² is usually needed and an application temperature between 25 and 45 °C or 77 and 113 °F is also necessary. During application, add-on parts and tapes must have the similar temperature.

17 PLACE PVC TRIM

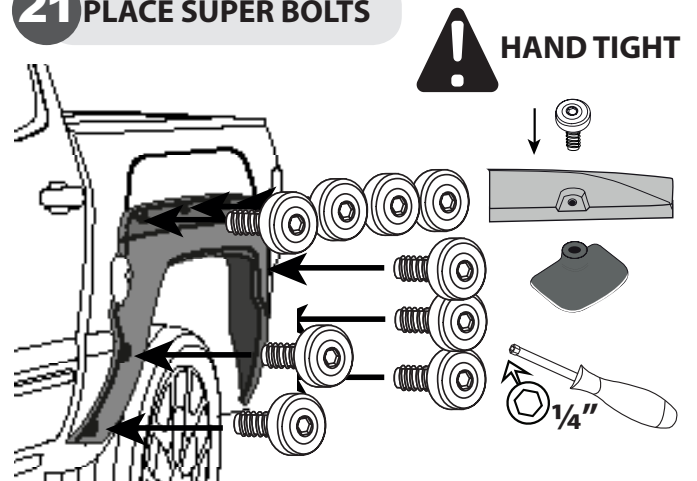
! INNER VIEW

18 PLACE

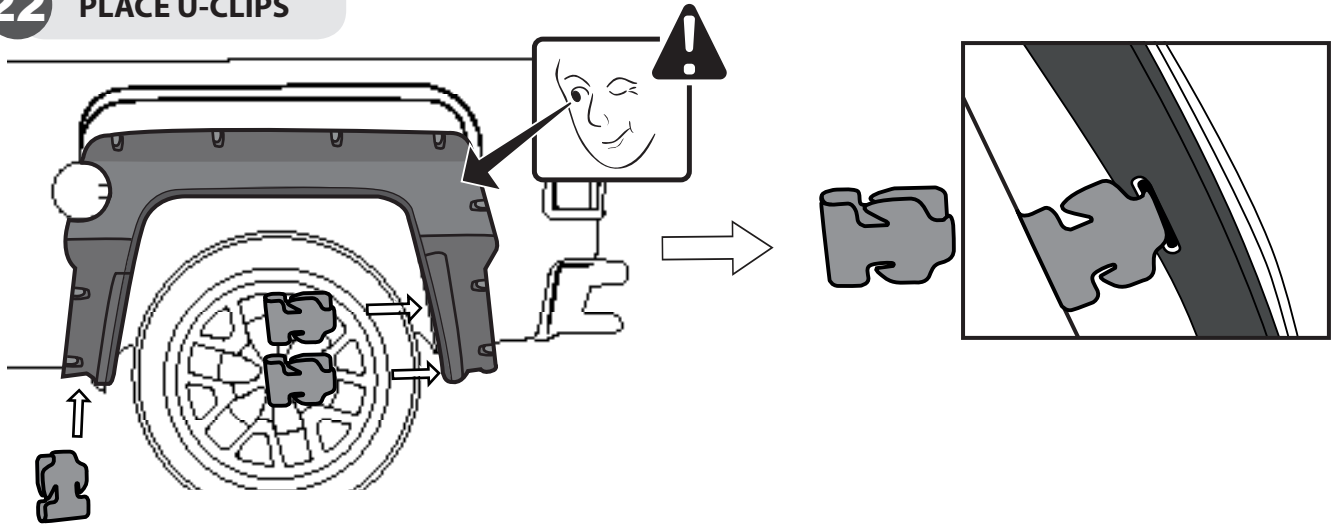
19 SECURE THE PART

20 APPLY LOCTITE THREADLOCKER TO SUPER BOLT'S THREAD

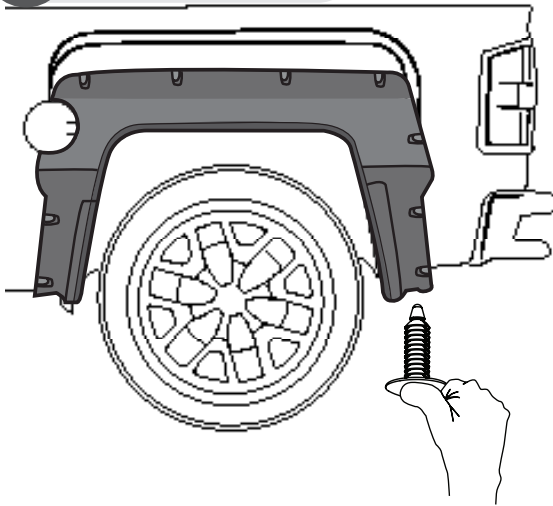
21 PLACE SUPER BOLTS

22 PLACE U-CLIPS



23 PLACE PUSH PINS



24 CLEAN OFF GREASE PENCIL MARK

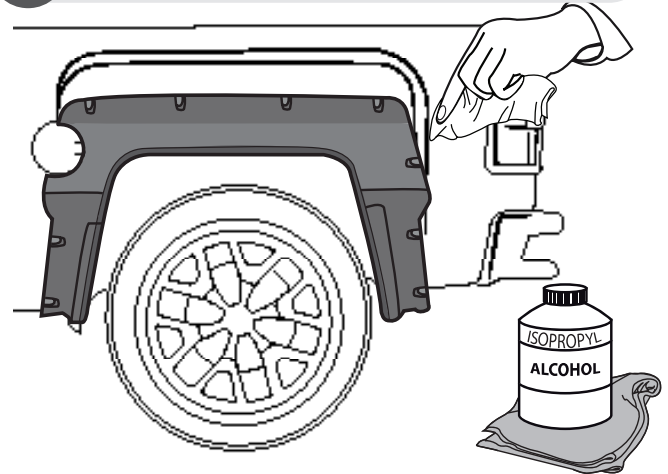

INSTALLED PARTS

