



CID DESIGN

SUPER RIM
TRUCK ACCESSORIES POWERED BY ANDERSON USA

DODGE- RAM1500 2013+



INSTALLATION MANUAL

TAILGATE APPLIQUE RAM 1500 2013+

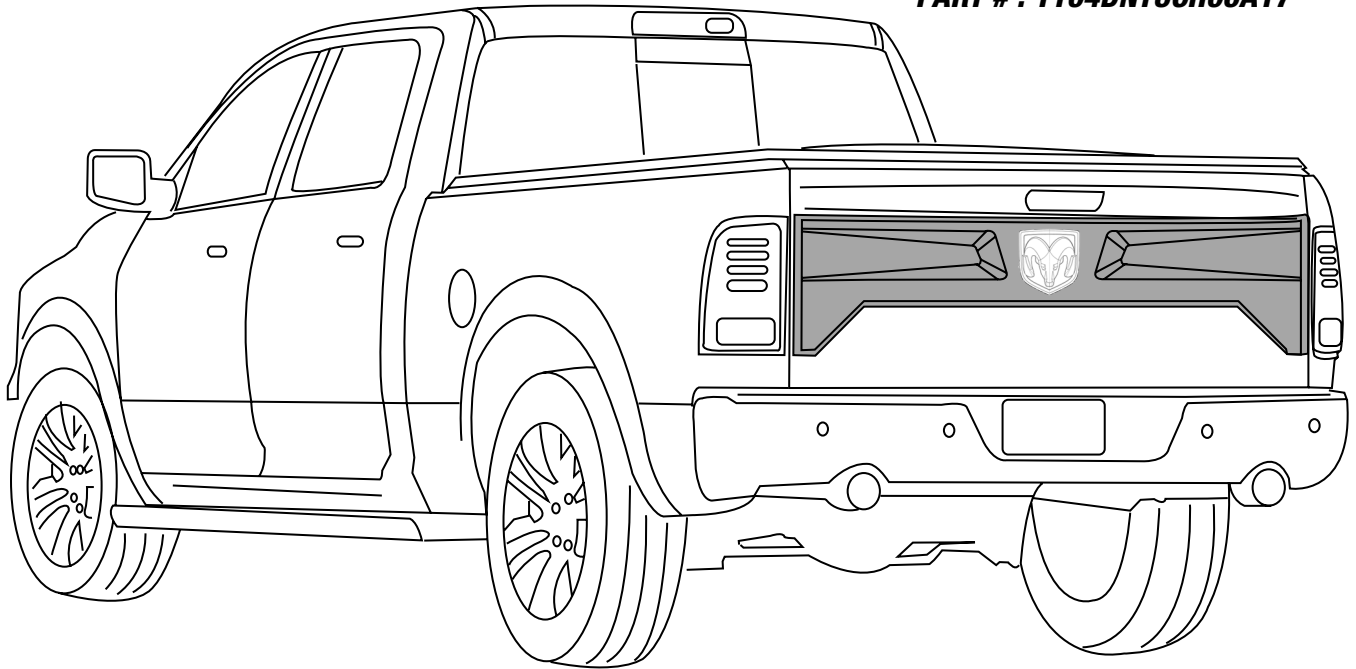
PART # : 1104DNTUCH06A17



DO NOT WASH CAR  **DRIVE SLOWLY**
25 mph max

 

24 hrs

READ CAREFULLY BEFORE INSTALLATION



We recommend 2 persons for installation

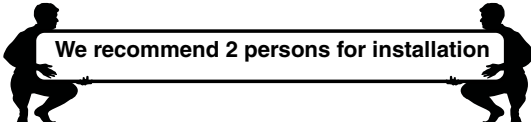





TOOLS



CHECK LIST

*Already installed in the part

ITEM	DESCRIPTION	DRAWING	AMOUNT
A	*VHB TAPE		INCLUDED IN PARTS
B	GREASE PENCIL		1PC
C	VHB DIE CUT		1PC
D	ADEHSION PROMOTER		1PC
E	ECO DOME		1PC

INSTALLATION MANUAL

1 REMOVE

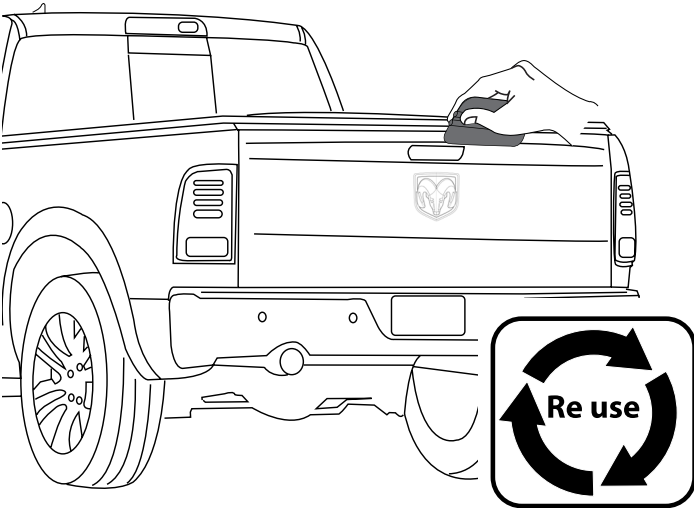

! WASH WITH WATER, DETERGENT AND SOFT CLOTH OR SPONGE

2 CLEAN

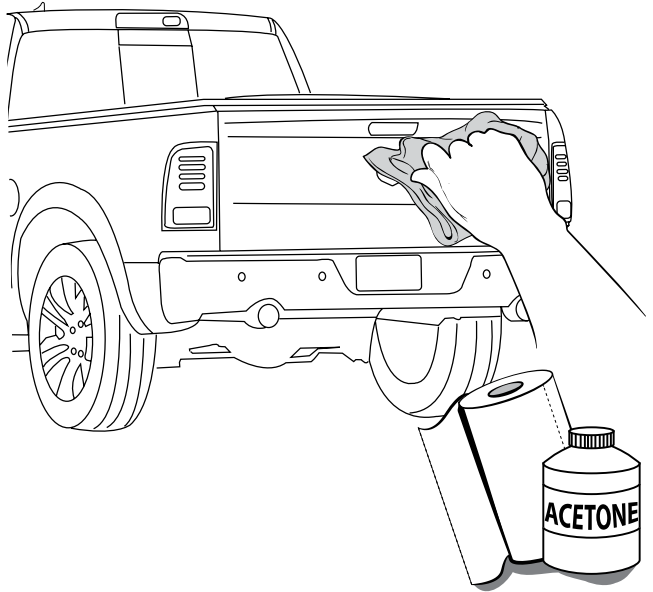

3 PRE-MOUNT

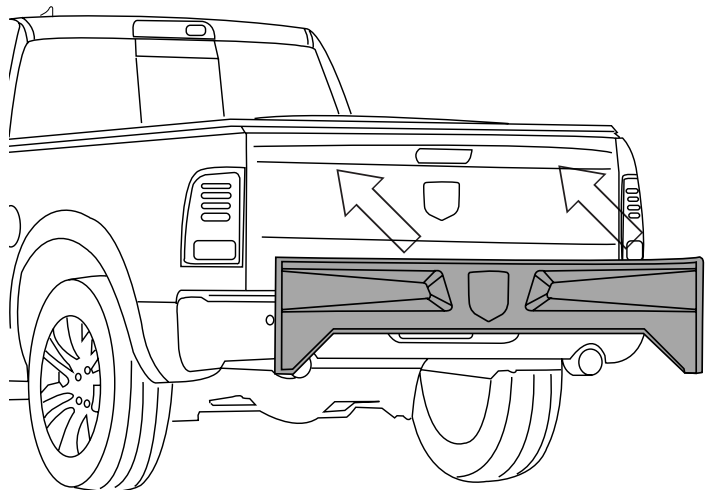

4 MARK

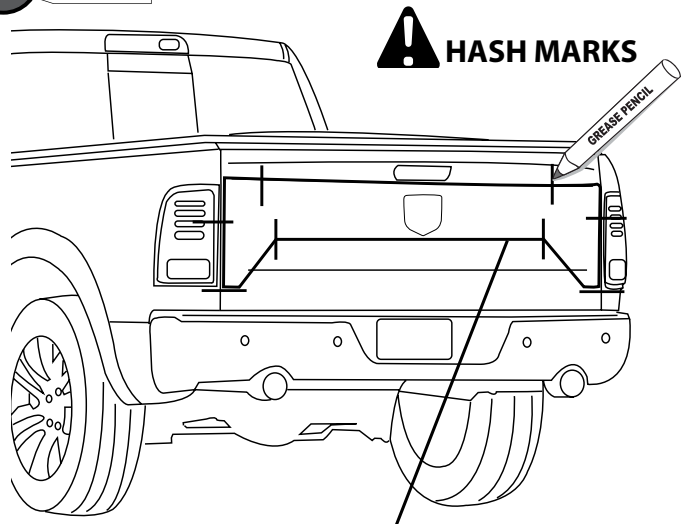

! HASH MARKS

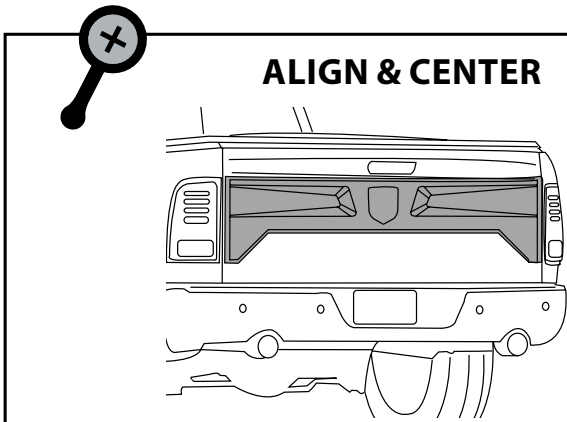

ALIGN & CENTER

CENTER ON BOTH SIDES

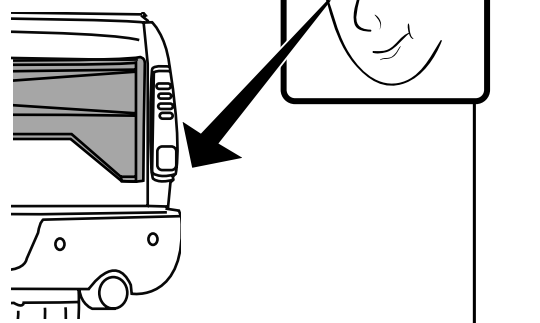

DRAW CENTER HASH MARK WITH GREASE PENCIL ON APPLIQUE AND SHEET METAL, THIS WILL ENSURE APPLIQUE WILL BE CENTERED TO GREASE PENCIL OUTLINE.



CID DESIGN

SUPER RIM
TRUCK ACCESSORIES POWERED BY ANDERSON USA

DODGE- RAM1500 2013+

INSTALLATION MANUAL

5 ADHESION PROMOTER



FIRST CLEAN ALL OVER THE APPLICATION AREA WITH ACETONE

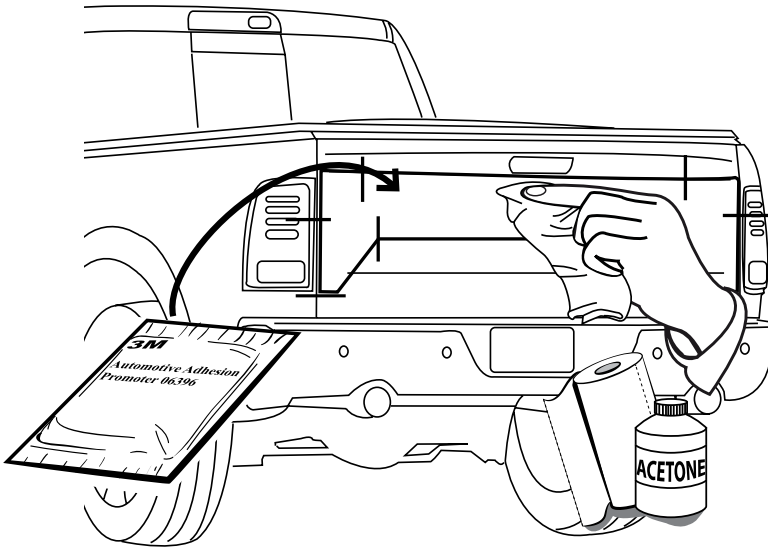

A full surface contact between tape and substrate is decisive for good adhesion performance. Contact is achieved by applying pressure. In practice a pressure between 40 and 50 N/cm² is usually needed and an application temperature between 25 and 45 °C or 77 and 113 °F is also necessary. During application, add-on parts and tapes must have the similar temperature.



WARM SURFACES WITH HEAT GUN IF SURFACE TEMPERATURE IS TOO COLD.

6 PEEL

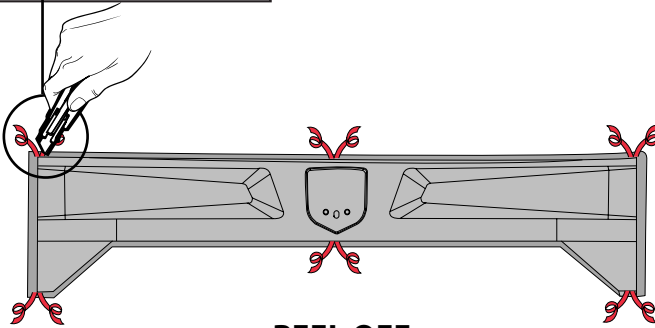
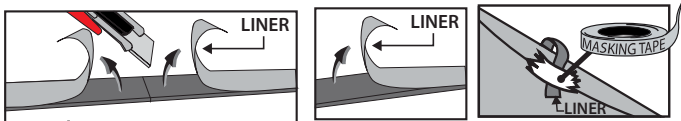

**PEEL OFF
HOLD THE LINER OUT**

7 PLACE

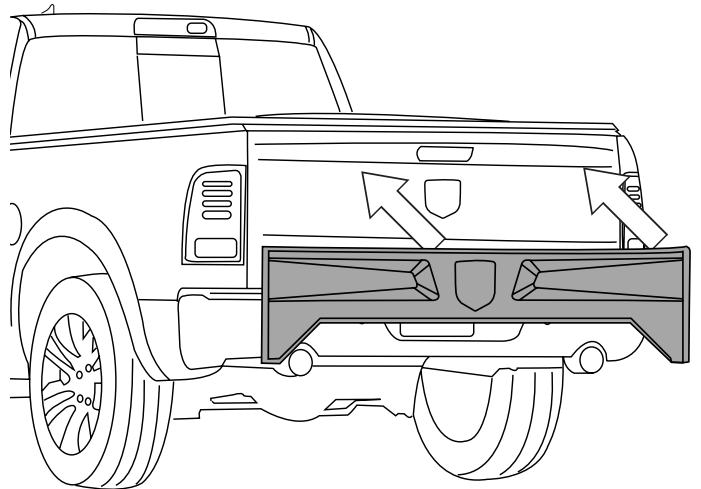

8 REMOVE LINER

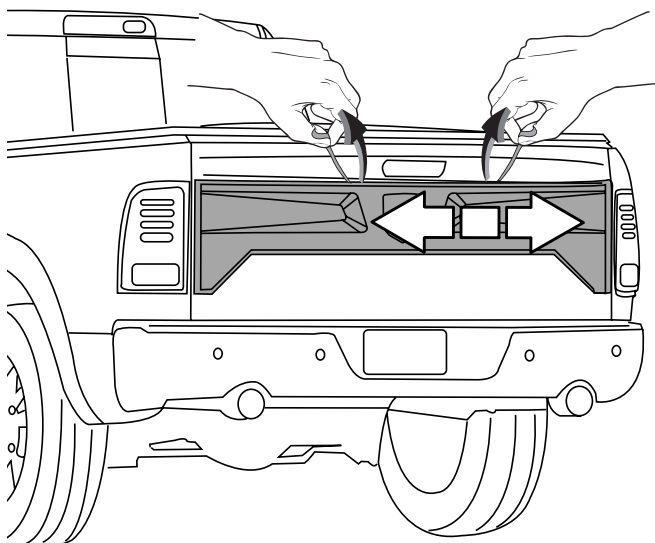

9 PRESS

APPLY PRESSURE

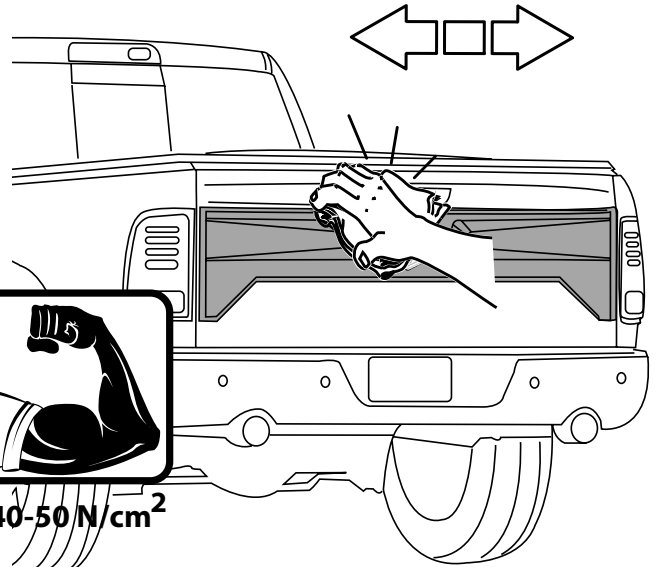

40-50 N/cm²

INSTALLATION MANUAL

10 CLEAN OFF GREASE PENCIL MARK

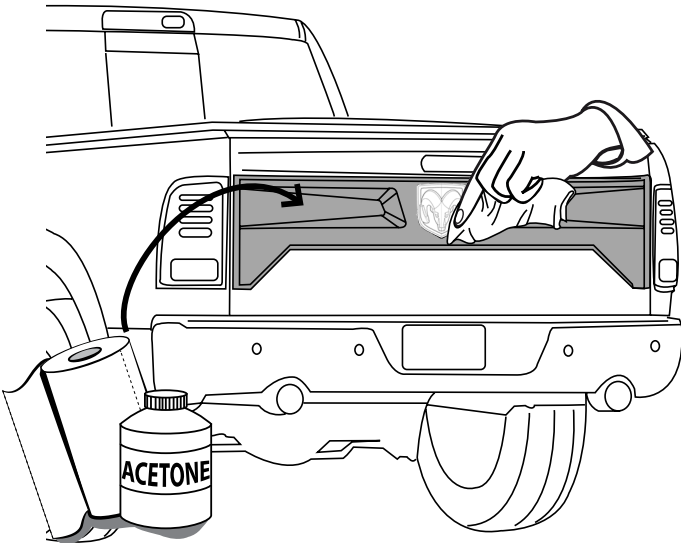

12 PLACE

PLACE VHB DIE CUT TO THE ORIGINAL EMBLEM

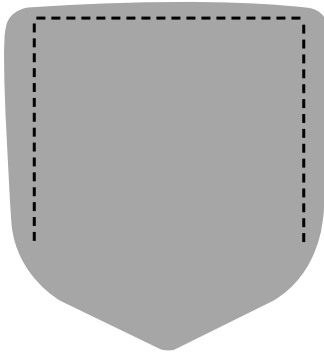

14 PRESS & APPLY PRESSURE

CENTER AND ALIGN

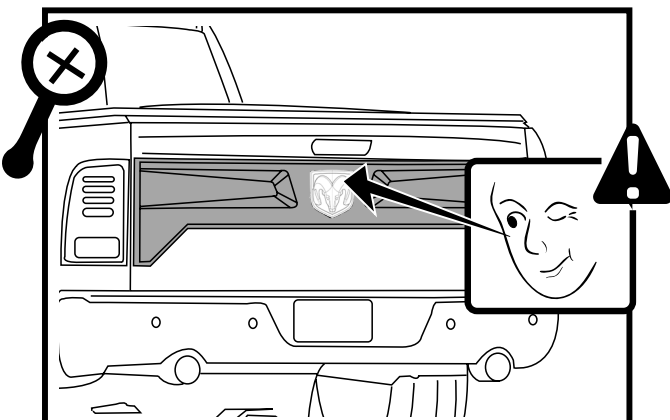

11 EMBLEM RECESS

1. FIRST CLEAN THE BACKSIDE OF THE EMBLEM THOROUGHLY WITH ALCOHOL, WIPE IT OFF WELL WITH A CLEAN CLOTH.
2. THEN APPLY ADHESION PROMOTER ALL OVER THE AREA.

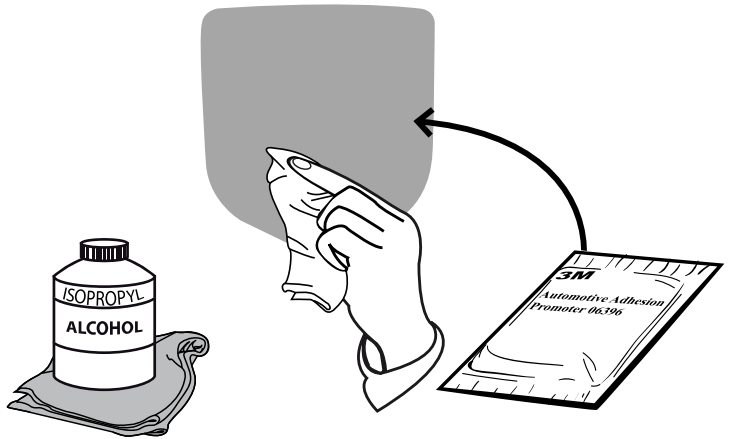

13 ADHESION PROMOTER

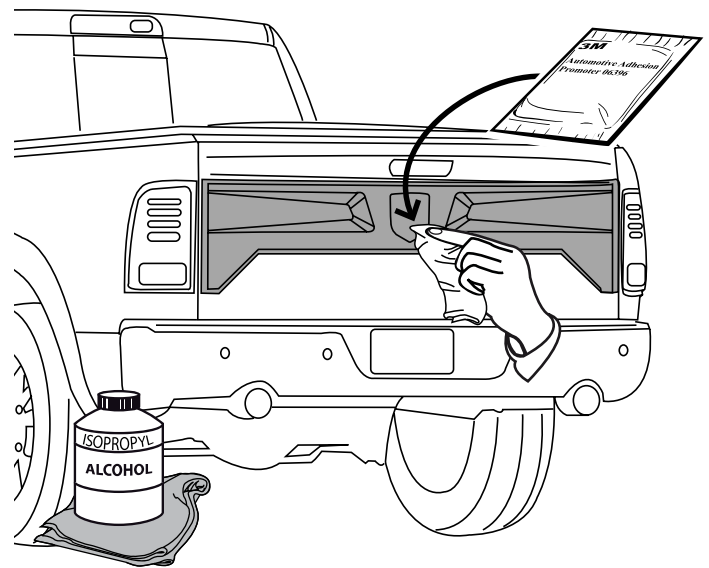

- !**
1. FIRST CLEAN ALL OVER THE APPLICATION AREA WITH ALCOHOL
 2. THEN APPLY ADHESION PROMOTER ALL OVER THE AREA

INSTALLED PART

