



**CID DESIGN**

**SUPER RIM**  
TRUCK ACCESSORIES POWERED BY AMERICAN USA



# GM - SILVERADO 2016

## INSTALLATION MANUAL

### TAILGATE APPLIQUE SILVERADO 2016

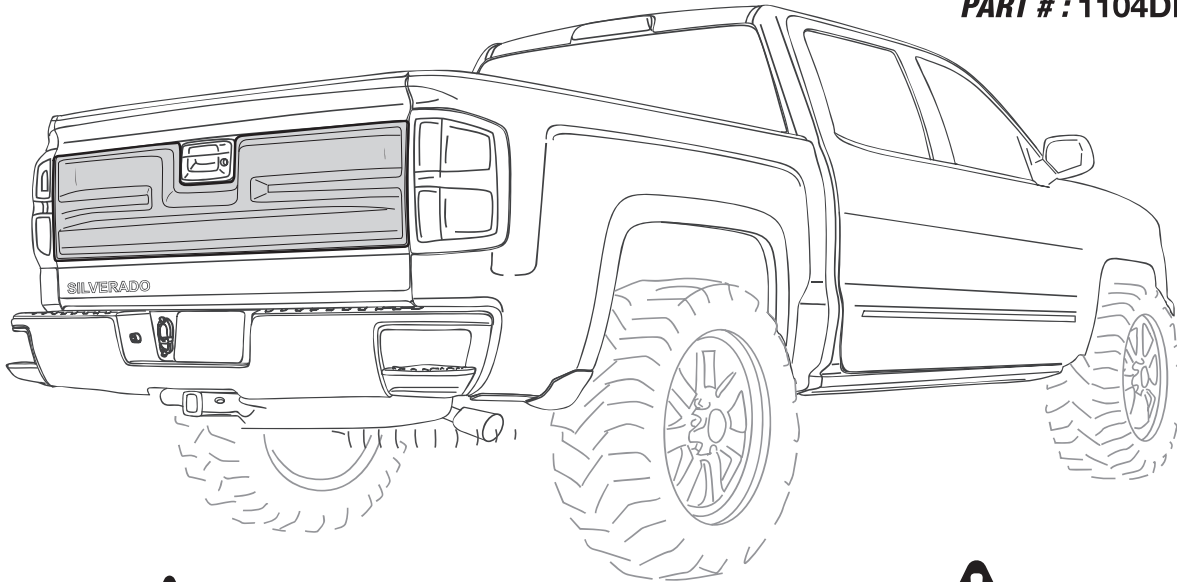
PART # : 1104DNTUGM24A15

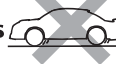

 **55 mph max**  
 **24 hrs** 

 **READ CAREFULLY BEFORE INSTALLATION**





 **We recommend 2 persons for installation**

### TOOLS

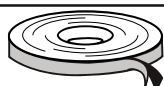

### CHECK LIST

\*Already installed in the part

ITEM	DESCRIPTION	DRAWING	AMOUNT
<b>A</b>	* VHB TAPE		Included in the parts
<b>B</b>	GREASE PENCIL		1 pc
<b>C</b>	ADHESION PROMOTER		1 pc
<b>D</b>	ECO DOME		1 pc



CID DESIGN

**SUPER RIM**  
TRUCK ACCESSORIES POWERED BY INNOVATION USA

# GM - SILVERADO 2016

## INSTALLATION MANUAL

**!** WASH WITH WATER, DETERGENT AND SOFT CLOTH OR SPONGE

### 1 CLEAN

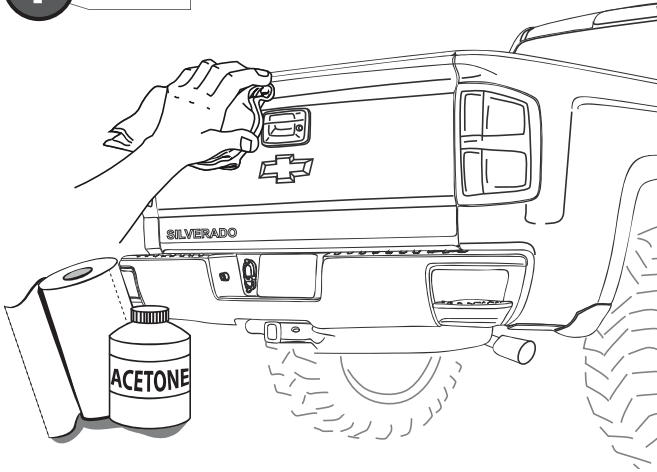

### 2 PRE-MOUNT

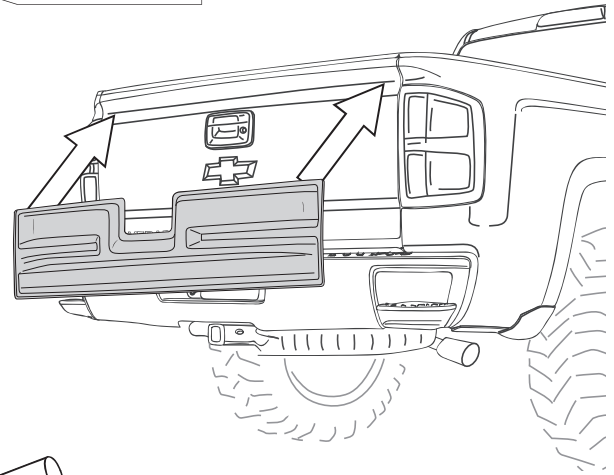

### 3 MARK

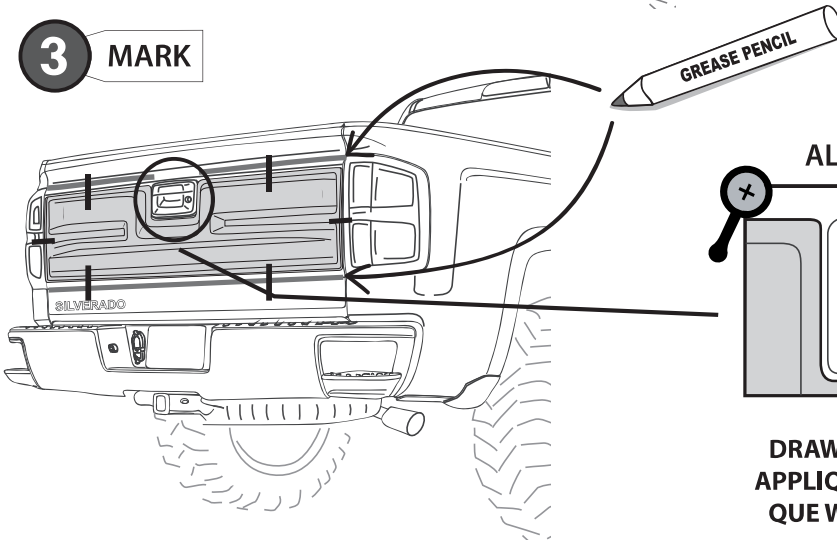

ALIGN & CENTER

**!** HASH MARKS

DRAW CENTER HASH MARK WITH GREASE PENCIL ON APPLIQUE AND SHEET METAL, THIS WILL INSURE APPLIQUE WILL BE CENTERED TO GREASE PENCIL OUTLINE.

### 4 ADHESION PROMOTER

**!** FIRST CLEAN ALL OVER THE APPLICATION AREA WITH ACETONE

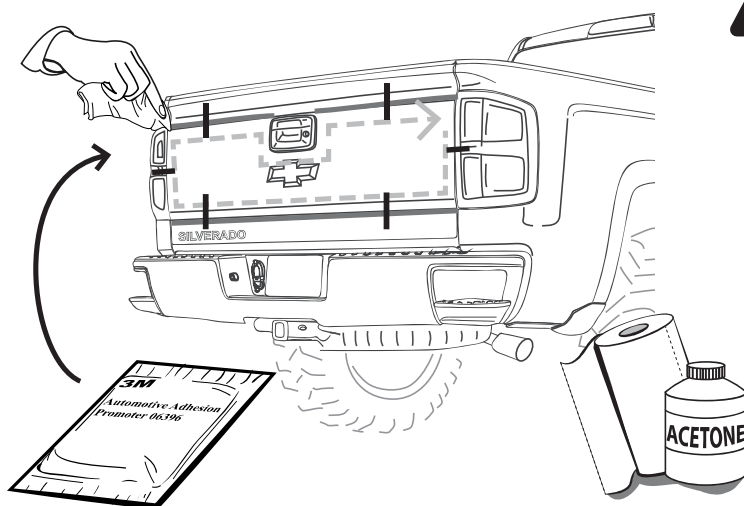

**!** A full surface contact between tape and substrate is decisive for good adhesion performance. Contact is achieved by applying pressure. In practice a pressure between 40 and 50 N/cm<sup>2</sup> is usually needed and an application temperature between 25 and 45 °C or 77 and 113 °F is also necessary. During application, add-on parts and tapes must have the similar temperature.



CID DESIGN

**SUPER RIM**  
TRUCK ACCESSORIES POWERED BY AMERICAN USA

# GM - SILVERADO 2016

## INSTALLATION MANUAL

**5 PEEL** **WARM SURFACES WITH HEAT GUN IF SURFACE TEMPERATURE IS TOO COLD.**

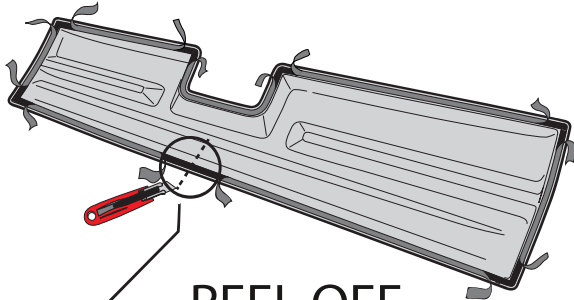

**PEEL OFF**  
Hold the liner out

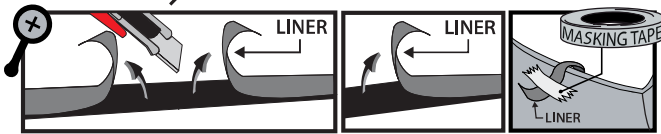

**6 PLACE**

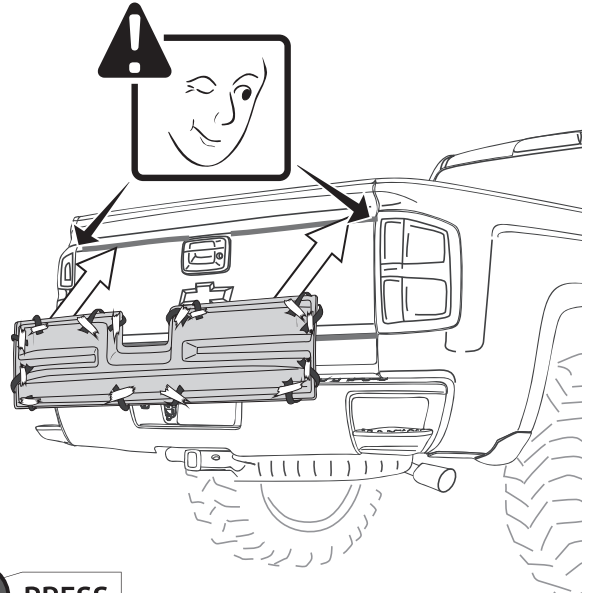

**7 REMOVE LINER**

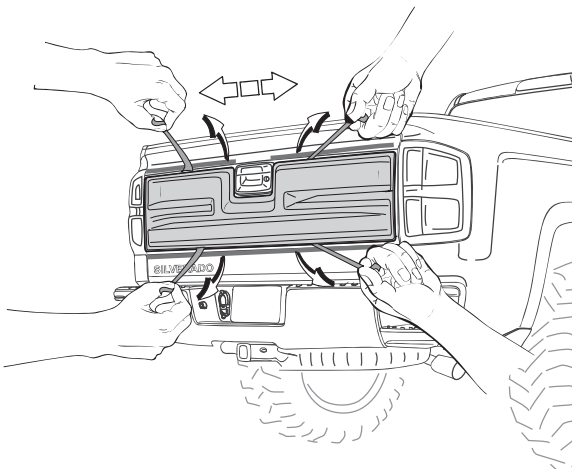

**8 PRESS**

**APPLY PRESSURE**

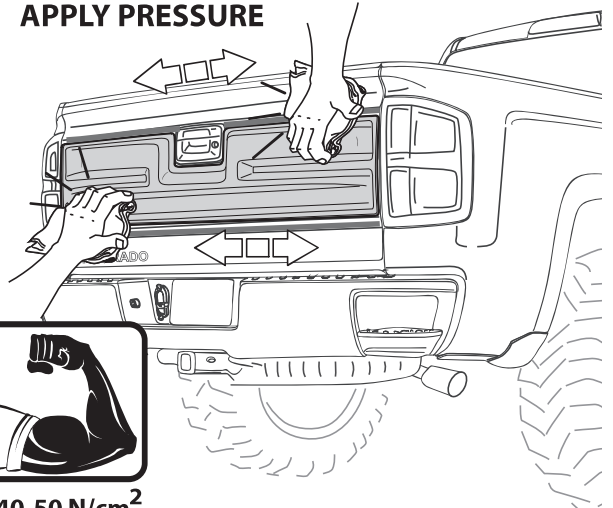

40-50 N/cm<sup>2</sup>

**9 CLEAN OFF GREASE PENCIL MARK**

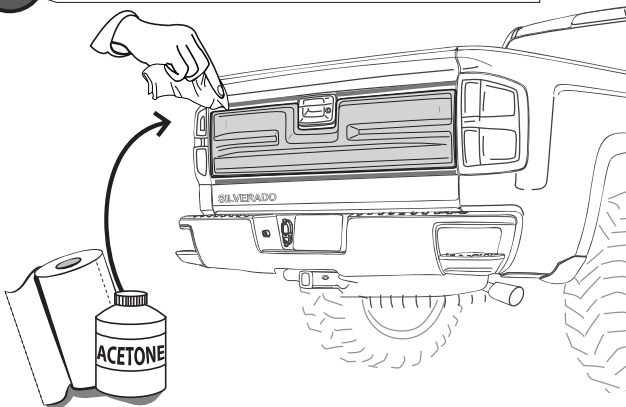

### INSTALLED PART

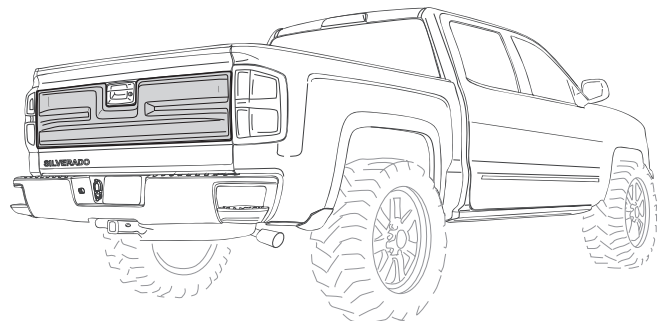

Add style with first-class chrome trim accessories we offer.