

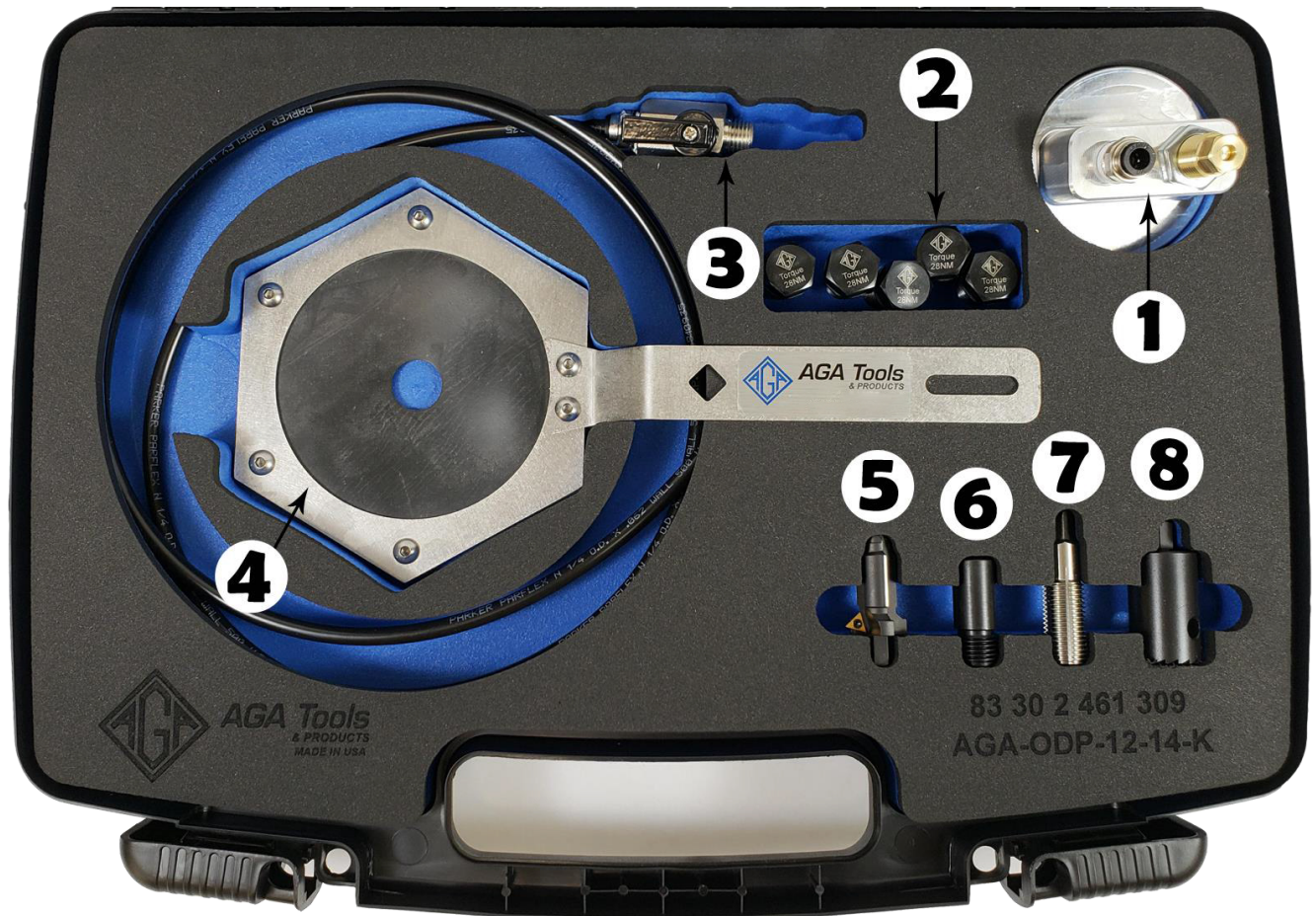

Oil Drain Plug Repair Kit

Part #: AGA-ODP-12-14-K

BMW Part #: 83 30 2 461 309



1. Oil cap with regulator

2. Oil drain plugs

3. Air supply hose with valve

4. Debris shield

5. Boring tool (drill bit)

6. Alignment tool

7. Thread forming tap (M14)

8. Re-facing tool



IMPORTANT: This thread repair tool and thread repair procedure should only be used by technicians that are familiar with thread repairs.

The tools are made of high quality materials but they need to be cleaned periodically during this procedure and lubricated at all times.

The boring tool and the thread forming tap are lubricated by the engine oil exiting the engine while under pressure. Some additional lubricant may be required.

The re-facing tool requires lubrication, use spray lubricant or equivalent.



Step 1: Drain the engine oil (1).

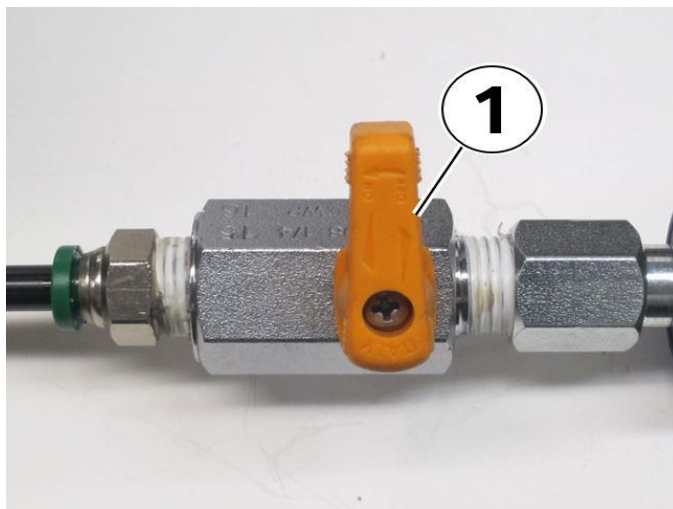

Step 2: Turn the air supply valve off (1).

Do not connect the shop air supply yet.

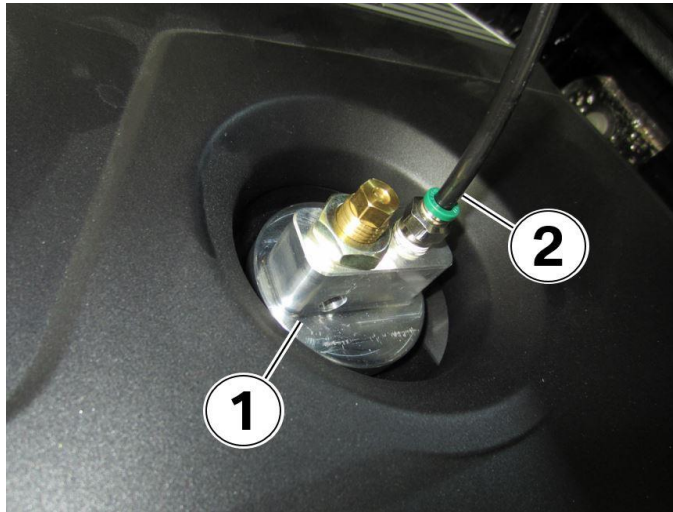

Step 3: Remove the engine oil cap and install the oil cap with regulator (1).

Install the black air supply hose (2).

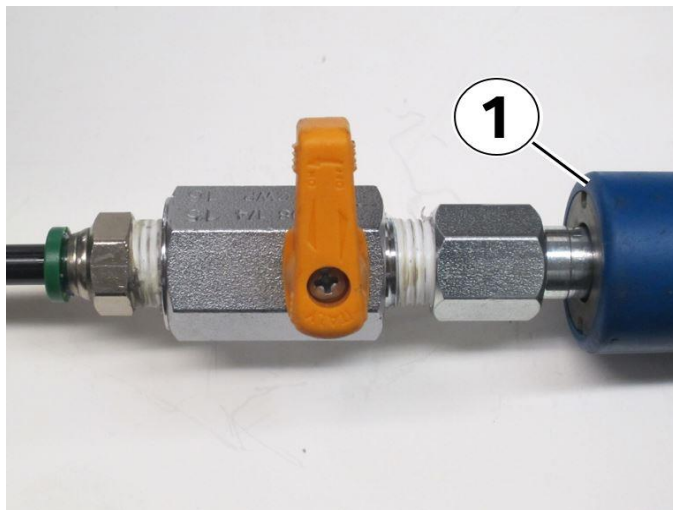

Step 4: Connect the shop air supply hose (1).

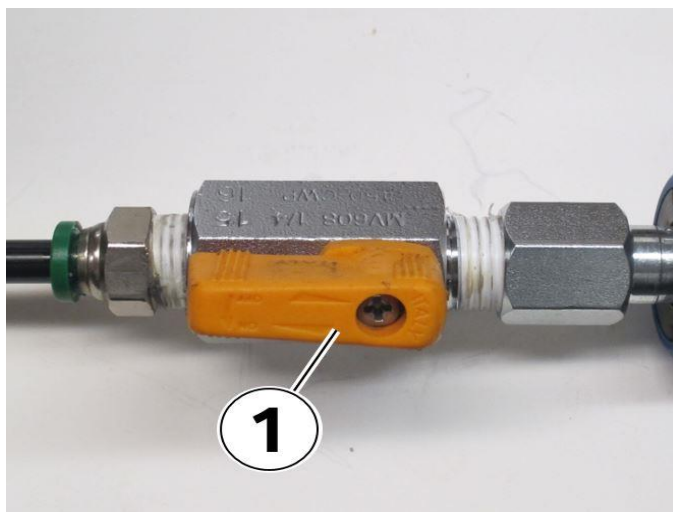

Step 5: Turn the air supply valve on (1).

Note: The air supply will be greatly reduced entering the engine using the special oil cap with regulator.



Step 6: Engine oil will begin to exit the oil pan again (1) with the air supply valve in the on position.

The oil dripping will be greatly reduced after approximately 90 seconds.

Wait before proceeding to the next step.



Step 7: Turn air supply valve off (1).

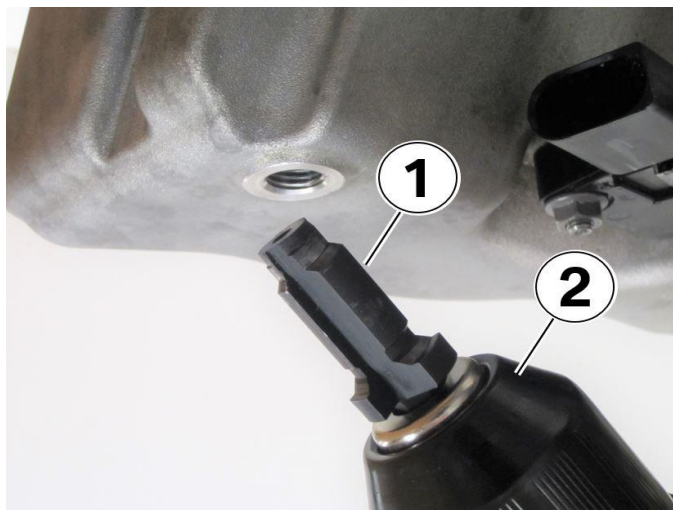

Step 8: Install the boring tool (1) into a suitable cordless drill (2).

Recommended cordless drill setting:

- Low speed or speed 1
- Lock the clutch
- Clockwise rotation



Step 9: The air supply valve (1) is still off.

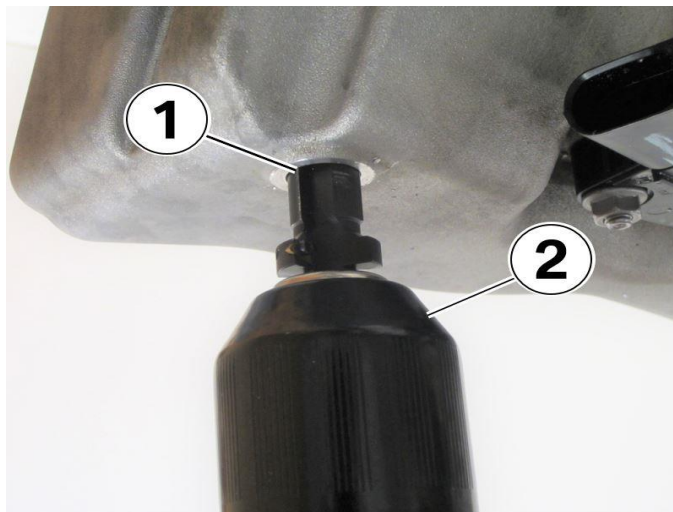

Step 10: Start the boring procedure. Rotate the drill (2) slowly and apply a little pressure upward into the oil pan drain plug hole.

Insert the boring bit and begin boring to approximately 3-4 mm deep (1). Stop when 3-4 mm has been reached.

Remove the boring tool from the hole.

Note: Starting the boring process without the air supply turned on is less distracting and will allow you to get the hole centered and squared to the engine oil pan.

No metal will enter the oil sump if you stop at approximately 3-4mm.

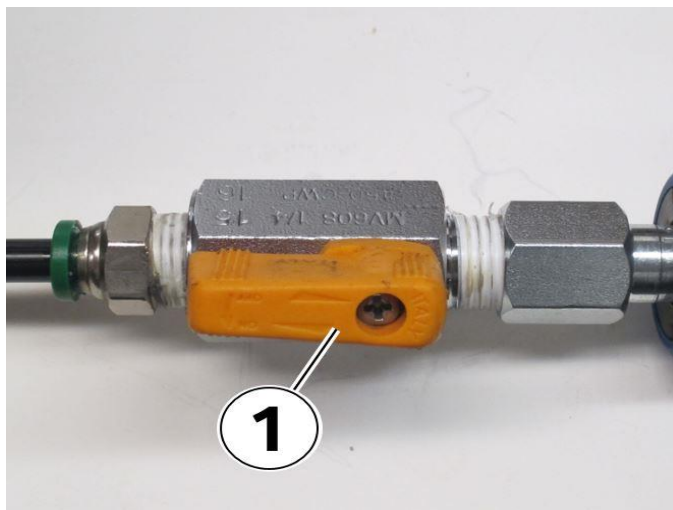

Step 11: Turn the air supply on (1).

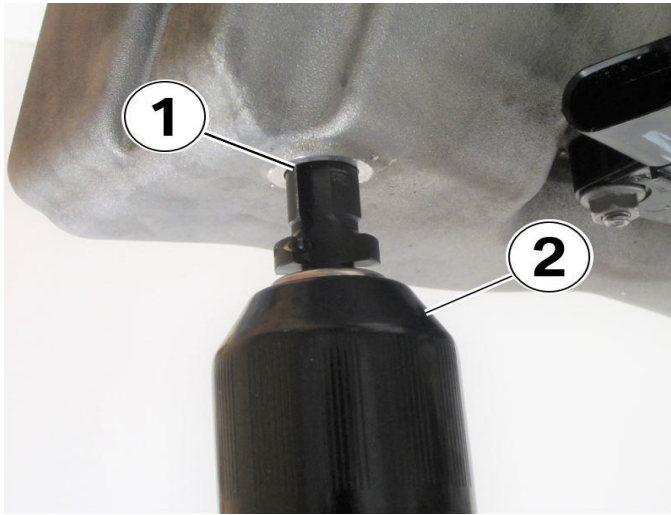

Step 12: When you resume boring the engine oil pan, metal chips will exit with the air pressure.

Be sure to wear proper safety equipment!



Optional debris shield in use.

Place the debris shield over the boring bit to shield any debris away from the drill operator.

A 2nd person may be used for this function so that the drill operator can continue using two hands on the drill.

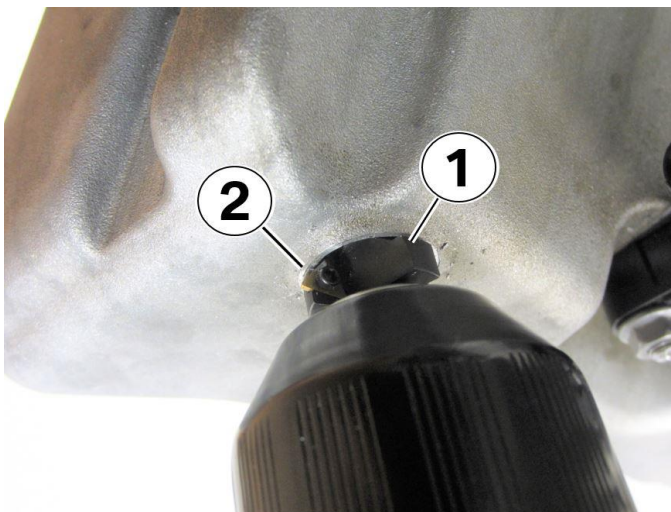

Step 13: Continue boring the hole (1) until the shoulder of the tool makes contact with the oil pan.

Once the tool stops developing cutting shavings, the modified bore and the chamfer (1) are complete.

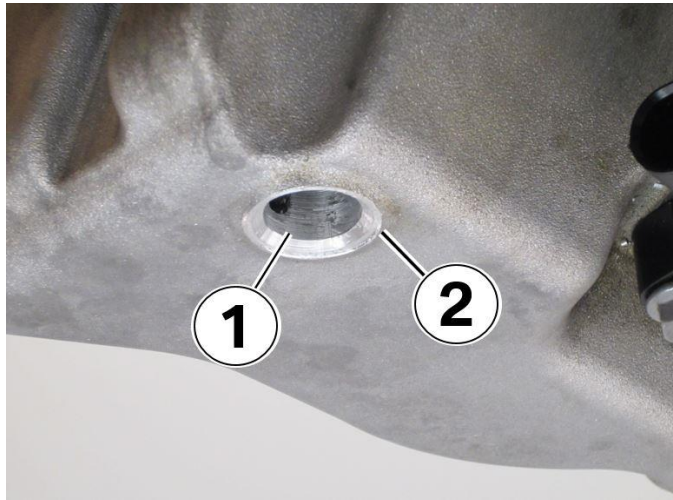

Step 15: Inspect the bore (1) and the chamfer (2).

Wipe away any loose debris with a shop towel.

Note: The chamfer will help start the thread forming tap.

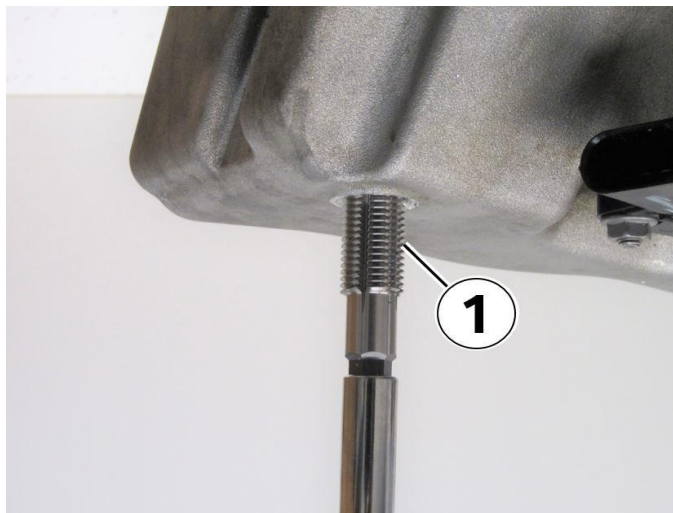

Step 16: Use an 8mm socket with a ratchet.

Insert the thread forming tap (1) into the hole.

Turn the tap slowly clockwise while applying slight upward pressure.

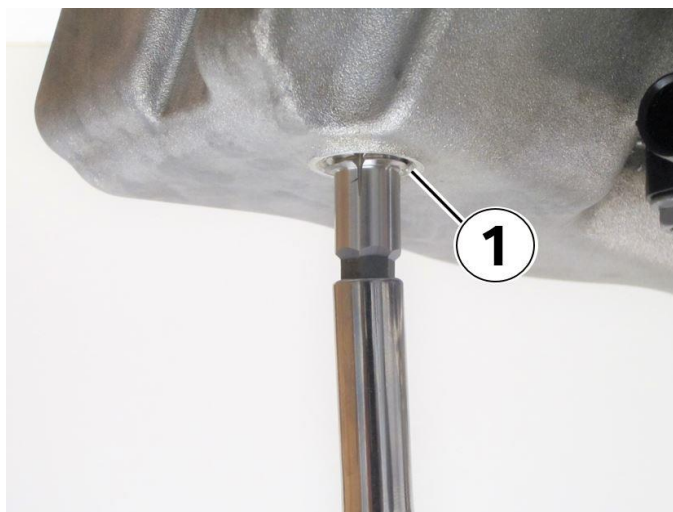

Step 17: Continue turning the tap until the last thread is flush with the outer pan surface (1).

Rotate the tap counter clockwise to remove it.

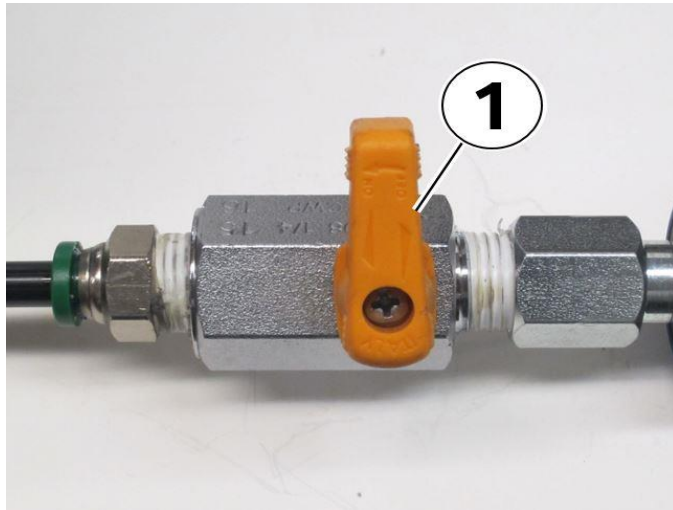

Step 18: After the tap is removed, turn the air supply valve off (1). Disconnect the shop air supply from the valve; the shop air supply is no longer needed.



Step 19: Wipe away any debris with a shop towel.

Inspect the chamfer and the thread (1).

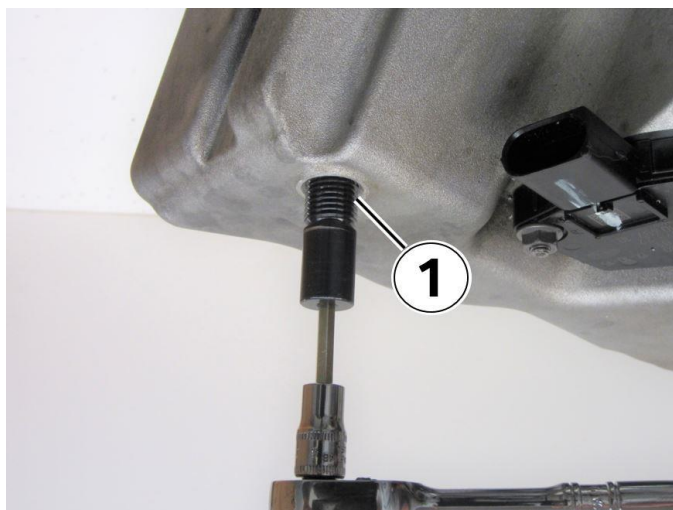

Step 20: Inset the alignment pin (1) with a 1/8 or 5mm Allen socket until it is flush with the oil pan surface.

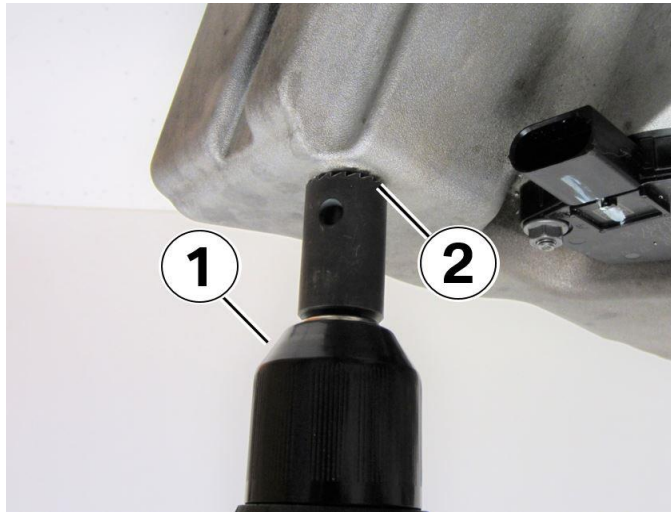

Step 21: Install the re-facing tool into a drill (1). Recommended drill setting is:

- Low speed or speed 1
- Lock the clutch
- Clockwise rotation

Place the re-facing tool over the alignment tool (1) and begin re-facing the seal surface (2).

Apply medium pressure to begin resurfacing the seal surface.

The re-facing tool will make the sealing surface perpendicular to the newly threaded hole.

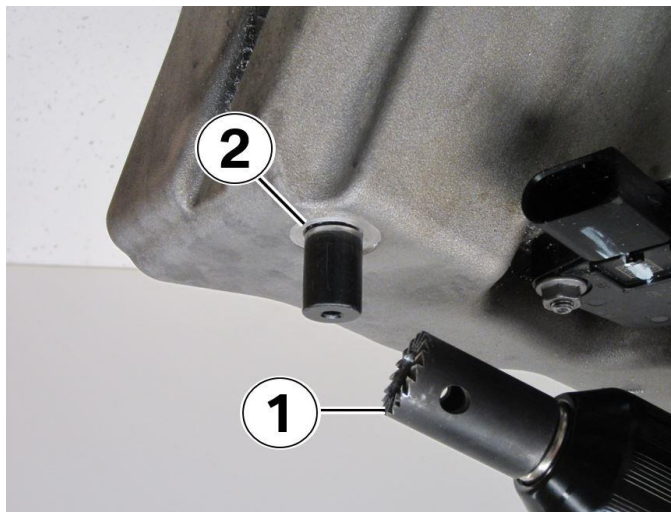

Step 22: Remove the re-facing tool (1) from the alignment pin.

Inspect the sealing surface. The sealing surface should be smooth and clean to ensure an oil leak will not occur.

Repeat as necessary to achieve smooth results.

Clean and lubricating the cutting teeth on the re-facing tool periodically using a pick and shop towel will achieve the best quality.

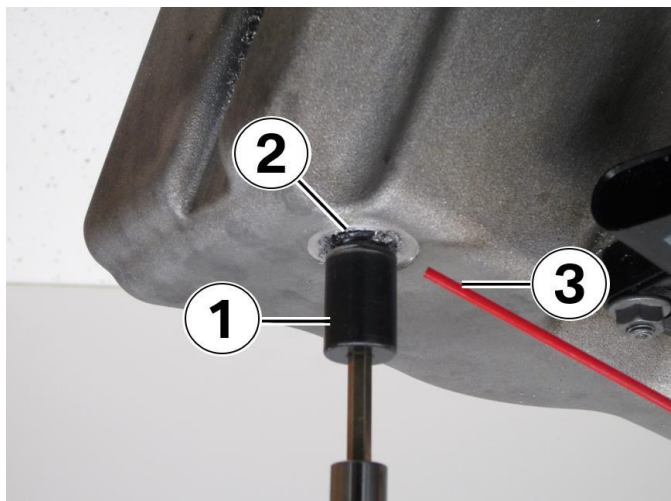

Hint: After the first cut, rotating the tool slowly with light pressure will polish the sealing surface while removing minimal material to achieve a superior sealing surface.

Step 23: Turn the alignment pin two turns counter clockwise. Do not remove it yet.

Use solvent and a shop towel to clean the threads of the alignment pin before removing it entirely. Wipe clean again once alignment pin is removed.

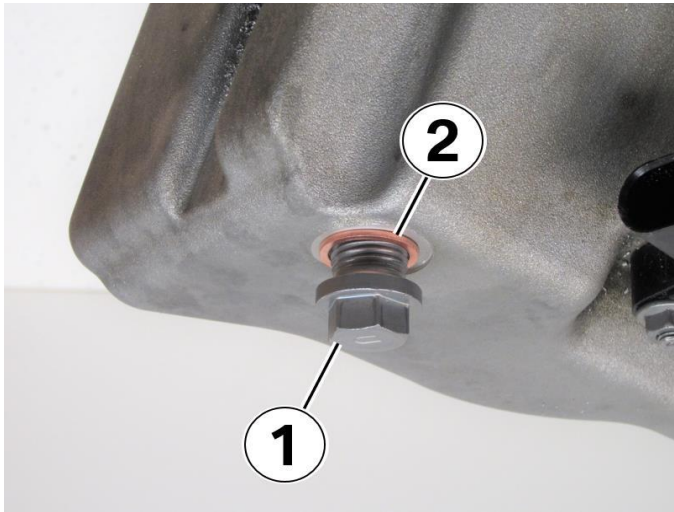

Step 24: Install the new drain plug that is supplied in this repair kit.



Step 25: Set the torque wrench to 28 Nm (20 ft-lbs).

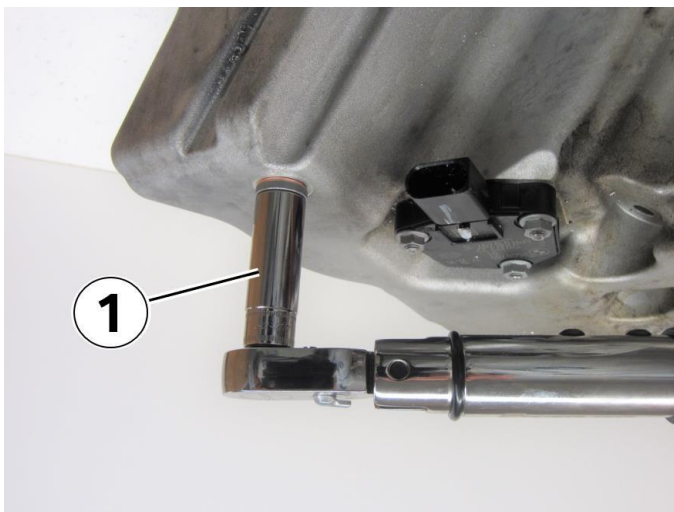

Step 26: Torque the drain plug (1).

Remove the oil cap with regulator.

Fill the engine with the proper engine oil and quantity.