



**AMERICANFORGE&FOUNDRY™**

## **Super Duty Air/Hydraulic Bottle Jacks**



5612SD



5620SD



5630SD

- ✓ The most innovative air assist bottle jack available today
- ✓ Fully welded tank and frame for superior strength and rugged durability
- ✓ 1-1/8" thick base design provides stable lifting platform even on poor surfaces
- ✓ Specially engineered air motor for consistent and reliable operation
- ✓ Dual return springs allow easy and controlled descent
- ✓ Shielded release screw helps prevents accidental lowering or damage
- ✓ Model 5621SD offers 7" low height for the most extreme space constraints

MODEL	CAPACITY	LOW HEIGHT	HIGH HEIGHT	LIFT	AIR PRESSURE	AIR FITTING	WEIGHT (LBS)
5612SD	12 Ton	9.92"	18.98"	5.91"	110-120 PSI	1/4" NPT	35
5620SD	20 Ton	10.37"	20.63"	6.38"	110-120 PSI	1/4" NPT	45
5621SD	20 Ton (Low Profile)	7.01"	12.76"	3.35"	110-120 PSI	1/4" NPT	36
5630SD	30 Ton	10.94"	20.59"	5.91"	110-120 PSI	1/4" NPT	65



# AMERICAN FORGE & FOUNDRY, INC.

## INSTRUCTIONS - Model 5612SD - 12 TON AIR/HYDRAULIC BOTTLE JACK

**IMPORTANT: READ THESE INSTRUCTIONS AND ALL WARNINGS PRIOR TO USING THIS EQUIPMENT. UNDERSTAND ALL OPERATING PROCEDURES, SAFETY WARNINGS AND MAINTENANCE REQUIREMENTS. FAILURE TO DO SO COULD CAUSE AN ACCIDENT RESULTING IN SERIOUS OR FATAL INJURY AND/OR PERSONAL PROPERTY DAMAGE.**

### WARNING

The use of shop equipment is subject to certain hazards that cannot be prevented by mechanical means, but only by exercise of intelligence, care, and common sense. It is therefore essential to have personnel involved in the use and operation of equipment who are careful, competent, trained, and qualified in the safe operation of this equipment and its proper use. Examples of hazards are dropping, tipping, or slipping of parts/components caused primarily by improperly securing loads, overloading, off-centered loads, use on other than hard level surfaces, and using equipment for a purpose for which it was not designed.

The owner and / or operator shall study and understand the product and safety instructions before operating this equipment. Safety information shall be emphasized and understood. If the operator is not fluent in English, the product and safety instructions shall be read to and discussed with the operator in the operator's native language by the purchaser / owner or his designee, making sure that the operator comprehends their contents. **A copy of these instructions / warnings shall be retained for future reference.**

### INSPECTION

Visual inspection shall be made before each use of this equipment, checking for abnormal conditions, such as cracked welds, leaks, damaged, loose or missing parts. This equipment shall be removed immediately from service if it is believed to have been subjected to an abnormal or shock load, the equipment shall be inspected by a qualified repair facility. Owners and / or operators should be aware that repair of this equipment may require specialized knowledge and facilities. It is recommended that this equipment be inspected annually by a qualified repair facility. Defective parts, decals, safety labels or signs should be replaced with AFF specified parts.

### WARNING

- Study understand, and follow all instructions before operating this device.
- When using various shop equipment, basic safety precautions should always be followed.
- Keep work area clean and free from debris.
- Keep children away from work area and shop equipment.
- Do not exceed rated capacity.
- Use only on hard, level surfaces.
- Lifting device only. Immediately after lifting, support the vehicle with appropriate means.
- Lift only on areas of the vehicle as specified by the vehicle manufacturer.
- Only attachments and/or adapters supplied by the manufacturer shall be used.
- No alterations shall be made to this product.
- Failure to heed these instructions may result in personal injury and/or property damage.



**AMERICAN FORGE & FOUNDRY, INC.**

## INSTRUCTIONS - Model 5612SD - 12 TON AIR/HYDRAULIC BOTTLE JACK

### 1. OPERATING INSTRUCTIONS

**WARNING! Ensure that you read, understand and apply the safety instructions and warnings before use.**

**WARNING! Ensure that you have familiarized yourself thoroughly with the product and the hazards associated with its improper use.**

- 1.1 Before first use of this product, pour a teaspoon of good quality air tool lubricant into the hose quick coupler-male, then connect it to air source and turn on the air valve and work for 3 seconds to evenly distribute lubricant.
- 1.2 Use the slotted end of the handle to turn the release valve clockwise until it is firmly closed.
- 1.3 Apply the emergency brake and use wheel chocks to block all wheels to prevent any movement of the vehicle being lifted.
- 1.4 Place the jack into position and adjust the extension screw as needed.

**NOTE:** Check in your vehicle owner's manual for the location of recommended lift point.

- 1.5 Connect the air quick coupler-male into the shop air supply hose quick coupler-female, then turn on the air valve.
- 1.6 Raise the load to desired height, turn off the air valve and immediately **USE JACK STANDS** with adequate capacity to support the load.
- 1.7 When air source is not available, insert the big end of the handle into the handle bracket, pump it manually to raise the load to desired height. Then immediately transfer the load to appropriate support devices such as jack stands.

**WARNING! Be sure all tools and personnel are clear before lowering load.**

- 1.8 When work is done, raise load enough to carefully remove the jack stands. Then **SLOWLY** and **CAREFULLY** lower the load by turning the release valve counterclockwise (use the slotted end of the handle) in extremely small increments, then lower the extension screw by turning it clockwise as needed and remove the jack.

**WARNING! Dangerous dynamic shock loads are created by quick opening and closing the release valve when the load is being lowered. The resulting overload may cause hydraulic system failure which could cause severe personal injury and/or property damage.**

### 2. MAINTENANCE

- 2.1 Clean the outside of the jack with dry, clean and soft cloth and periodically lubricate the joints, extension screw and all moving parts with a light oil as needed. **DO NOT APPLY LUBRICANT TO SADDLE.**
- 2.2 When not in use, store the jack in a dry location with ram and extension screw fully lowered.
- 2.3 Purge the hydraulic system to eliminate any air in the system if jack efficiency drops or jack doesn't work:
  - A. If manual operation performs poorly, use the slotted end of the handle to turn the release valve 1-1/2 turns counterclockwise and remove the oil filler plug by gently pulling, insert the handle into the handle bracket and pump it 10 to 15 times, then replace the filler plug.
  - B. If air operation performs poorly, connect the air inlet fitting to air source, use the slotted end of the handle to turn the release valve 1-1/2 turns counterclockwise and remove the oil filler plug by gently pulling, turn on the air valve to let the pump work for one minute, then replace the filler plug.
- 2.4 Check the hydraulic oil: place the jack in an upright position, completely lower the ram and remove the filler plug, if it is not adequate, fill with high quality hydraulic jack oil to the lower rim of the fill hole, purge away air from the hydraulic system as described in 2.3, top off with more hydraulic oil, then replace the filler plug.



# AMERICAN FORGE & FOUNDRY, INC.

## INSTRUCTIONS - Model 5612SD - 12 TON AIR/HYDRAULIC BOTTLE JACK

2.5 For best performance and longest life, replace the complete jack oil at least once per year: With the ram fully lowered, remove the oil filler plug, lay the jack on its side and drain the oil into a suitable container, then fill with high quality hydraulic jack oil as described in 2.4, reinstall the filler plug.

**NOTE:** Dispose of hydraulic oil in accordance with local regulations.

2.6 It is recommended that an annual inspection be done by qualified technicians.

### 3. TROUBLESHOOTING

Symptom	Possible Causes	Corrective Action
Jack will not lift load	Release valve not tightly closed Overload condition Air supply inadequate Air trapped in system	Close release valve firmly Remedy overload condition Ensure adequate air supply Purge away air from system
Jack will lift, but will not maintain pressure	Release valve not tightly closed Overload condition Hydraulic unit malfunction	Close release valve firmly Remedy overload condition Contact your local service center
Will not lower after unloading	Reservoir overfilled Linkages binding	Drain oil to proper level Clean and lubricate moving parts
Poor lift performance	Hydraulic oil level low Air trapped in system	Add oil to proper level Purge away air from system
Will not lift to max height	Hydraulic oil level low	Add oil to proper level

Capacity	Min Height	Ram Travel	Screw Adj.	Max Height	Air Pressure	Air Inlet Fitting
12ton	9.92"	5.91"	3.15"	18.98"	110-120 Psi	1/4" NPT



**AMERICAN FORGE & FOUNDRY, INC.**

**INSTRUCTIONS - Model 5612SD - 12 TON AIR/HYDRAULIC BOTTLE JACK**

**ONE YEAR LIMITED WARRANTY**

American Forge & Foundry, Inc. (AFF) warrants, to the final purchaser, all equipment distributed by AFF to be entirely free from operating defects in material and workmanship for a period of one year.

If a jack or related equipment is determined to be defective during the period, AFF, at its option, will repair or replace without charge provided that the equipment is shipped, transportation charges prepaid, with proof of purchase, to AFF or to an authorized Field Service Depot designated by AFF.

This warranty does not apply to products damaged by accident, overload, misuse or abuse, nor does it apply to any product, which has been modified, altered or used with special attachments other than those expressly recommended by AFF.

There are no other warranties express or implied, and Seller specifically disclaims any warranty of merchantability or of fitness for any particular purpose. The Seller's sole obligation, which shall represent the Buyer's sole and exclusive remedy, shall be to repair or at the Seller's option to replace any product or part determined to be defective as aforesaid. In no event shall the Seller be liable for any special, direct, indirect, incidental, consequential or other damages of a similar nature, including, without limitation, loss of profits or of production time, or loss of expenses of any nature, incurred by the Buyer or any Third party.



# MODEL 5612SD 12 TON SUPER DUTY AIR BOTTLE JACK

PART ORDER NUMBER	KIT DESCRIPTION	KIT INCLUDES		
		REF. #	DESCRIPTION	QTY
5612SD-RK	REPAIR KIT	2	RETAINING RING	1
		3	DUST RING	1
		4	O-RING	1
		5	LIMIT RING	1
		6	O-RING	1
		10	SEAL RING	1
		11	O-RING	1
		12	STEEL BALL CUP	1
		13	STELL BALL	6
		15	FILLER PLUG	1
		16	O-RING	1
		18	STEEL BALL CUP	1
		20	SPRING	2
		21	COPPER WASHER	2
		23	COPPER WASHER	2
		25	O-RING	1
		26	PTFE	1
		28	DUST RING	1
		36	STEEL BALL	1
		37	BASE FOR STEEL BALL	1
38	SPRING	1		
40	O-RING	1		
5612SD-1K	SPRING KIT	1	SPRING PLATE	1
		8	SPRING	2
		9	BOLT	2
5612SD-42	AIR MOTOR	42	AIR MOTOR	1
5612SD-43	CONNECTION FITTING	43	CONNECTION FITTING	1
5612SD-44	AIR HOSE	44	AIR HOSE	1
5612SD-45	AIR VALVE	45	VALVE BODY	1
5612SD-34K	HANDLE	34	HANDLE 1	1
		35	HANDLE 2	1
5612SD-24K	PUMP	24	PUMP	1
		23	COPPER RING	1
		25	O-RING	1
		26	PTFE	1
		27	PUMP CORE	1
		28	DUST RING	1
5612SD-32K	HAND PRESS	32	HAND PRESS	1
		33	PIN	2
		31	PIN	3
		30	HANDLE BRACKET	1
		29	R-PIN	1
5612SD-17K	RELEASE VALVE	17	RELEASE VALVE	1
		16	O-RING	1

**ONLY PARTS WITH A "PART ORDER NUMBER" ARE AVAILABLE.**

*THIS MATERIAL WITHOUT PERMISSION OF AFF, INC.*

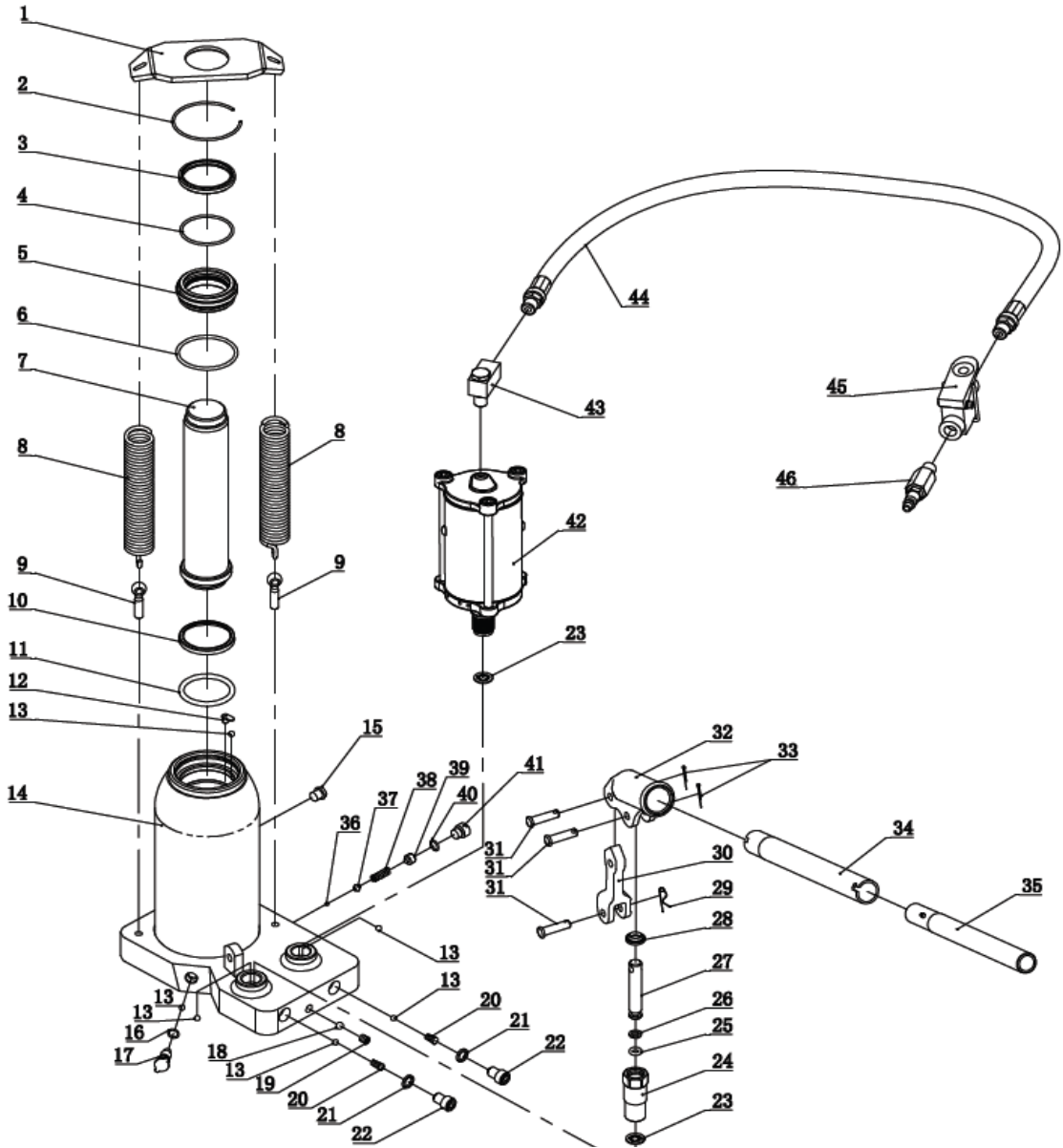

When it comes to quality car jacks, AFF is the brand you can depend on.