

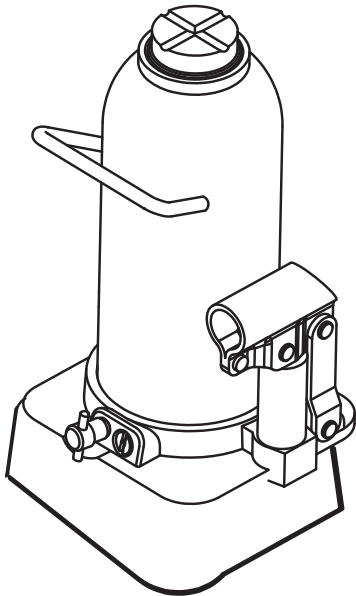

AMERICAN  
FORGE & FOUNDRY

# Super Duty Bottle Jack Instruction Manual Model 3602-3650



## Important!

Before operation of this jack carefully read and understand this manual and retain for future reference.

## SPECIFICATIONS

Model	Capacity (Ton)	Min Height (INCHES)	Max Height (INCHES)	Weight (LBS)
3602	2	7.12	13.54	5.95
3604	4	7.59	14.69	7.51
3606	6	8.26	16.38	9.92
3608	8	8.85	17.91	12.13
3612	12	9.05	17.32	14.77
3612S	12	7.48	14.17	12.79
3620	20	9.52	17.81	20.94
3620S	20	7.48	13.78	17.86
3630	30	10.82	17.32	27.34
3650	50	10.43	16.73	56.65

## PARTS DIAGRAM

1. Piston rod
2. Wire retaining ring
3. Snap ring
4. O-ring
5. Oil plug
6. Hydraulic cylinder
7. Release valve rod
8. Safety valve
9. Pump plunger
10. Pin

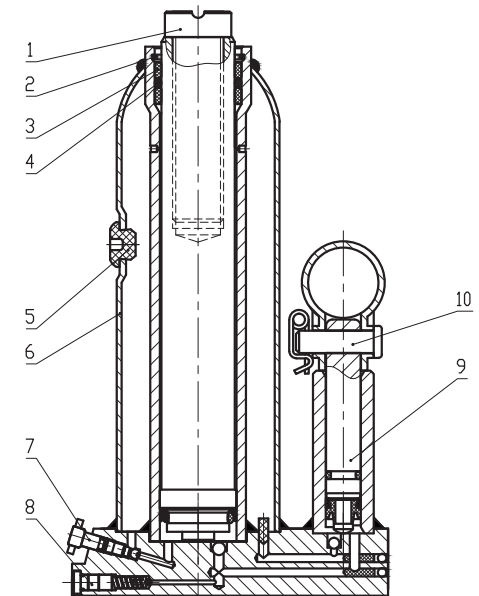

## OPERATION

The owner and/or operator is responsible for product maintenance, making sure all decals and warning labels are clearly visible and free of dirt, and keeping the unit in good working order. If the operator is not fluent in English, the product warnings and instructions shall be read and discussed in the operator's native language by the purchaser/owner or his designee. All safety information shall be emphasized and understood prior to usage, and the jack should be inspected before each use.

It is the owner and/or operator's responsibility to study all warning, operating, and maintenance procedures found on the product label and instruction manual prior to operation of this unit. A copy of these instructions shall be retained for future use.

### Raising Vehicle

1. Verify that both the jack and the vehicle are on a hard and level surface.
2. Always set the vehicle parking brake and chock the wheels.
3. Consult the vehicle owner's manual to verify the location of the approved lifting points and position the jack on a lifting point where the vehicle needs to be raised.
4. Turn the release valve clockwise to the closed position. Do not overtighten.
5. To raise the vehicle to a desired height place the bottle jack handle into the socket and pump up and down.
6. Place safety stands beneath the vehicle at locations recommended by the vehicle manufacturer. Do not position yourself under the vehicle until safety stands are securely in place.
7. Slowly turn release valve counterclockwise until the load is placed directly on the safety stands.

### Lowering Vehicle

1. Turn the release valve clockwise to the closed position.
2. Pump the bottle jack handle to lift the vehicle slightly higher than the safety stand.
3. Remove the safety stands away from the vehicle. Do not position yourself under the vehicle while lowering.
4. Slowly turn the release valve counterclockwise to lower the vehicle onto the ground.

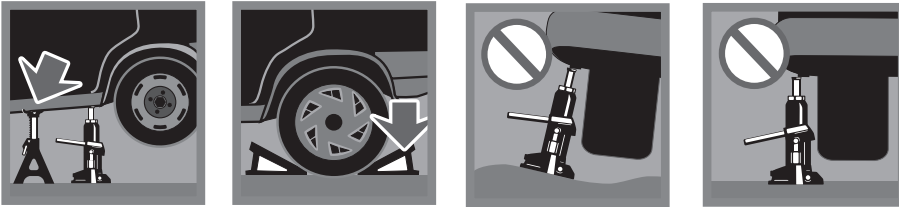

## INSPECTION

The product shall be maintained in accordance with the product instructions and no alterations shall be made to this product.

1. Before each use visually inspect the jack for any abnormal conditions such as cracked welds, damaged, bent, or worn parts, or any evidence
2. If the jack is believed to have been subject to abnormal shock or load it is to be taken out of service and sent to an authorized SureWerx service depot for repair.

## MAINTENANCE

Monthly maintenance is recommended for this product as proper lubrication is critical to the successful operation of lifting heavy loads. Any restriction due to dirt or rust can cause slow movement or cause a jerking motion which can damage internal components. The following steps are designed to keep the jack well lubricated.

1. Lubricate the ram, linkages, saddle, and pump mechanism with light oil.
2. Visually inspect for cracked welds, damaged, bent, or worn parts, or any evidence of hydraulic leaks.
3. Clean all surfaces including labels and warnings.
4. Check and maintain the hydraulic oil level.
5. Check ram every 3 months for any sign of rust or corrosion and clean as needed.
6. When not in use always leave the saddle and ram in the fully lowered position.
7. Always use high quality hydraulic oil only. Do not use brake fluid.

## CHECK OIL LEVEL

1. Turn the release valve counterclockwise to allow the ram to fully retract. It may be necessary to apply force to the saddle for lowering.
2. With the jack in a level position remove the oil fill plug. Keep jack in a vertical position with the handle socket down. The oil should be level with the bottom of the fill hole. If not fill reservoir with new hydraulic oil. Do not overfill.
3. Replace fill plug
4. Check jack operation.
5. Purge air from system as required.

## TROUBLESHOOTING

### SYSTEM AIR PURGE:

1. Turn release valve counterclockwise one full turn to open.
2. Pump handle eight full strokes.
3. Turn release valve clockwise to close valve.
4. Pump handle until the ram reaches maximum height and continue to pump several times to remove trapped air in the ram.
5. Carefully and slowly pinch oil fill plug to release trapped air.
6. Turn release valve counterclockwise one full turn and lower ram to the lowest position. Use force if necessary.
7. Turn release valve clockwise to closed position and check for proper pump action. It may be necessary to perform the above more than once to assume air is evacuated totally.

PROBLEM	POSSIBLE CAUSE	ACTION
Jack will not lift to full height	Low oil level	Check oil level
Jack will not hold load	Release valve not closing Hydraulic jack oil contaminated Pump valves not sealing Cylinder ram binding	Call customer service
Jack will not lower	Cylinder ram binding Parts worn Internal damage	Call customer service
Jack feels spongy when lifting	See Air Purge section	See Air Purge procedure