



AMERICANFORGE&FOUNDRY™

MODEL: 3225

Operating Guide

20 Ton Air/Hydraulic Service Jack

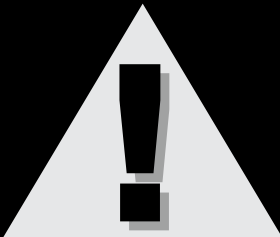

WARNING:

Important: Read these instructions and all warnings prior to using this equipment. Understand all operating procedures, safety warnings and maintenance requirements. Failure to do so could cause an accident resulting in serious or fatal injury and/or personal property damage.



WARNING!

The use of shop equipment is subject to certain hazards that cannot be prevented by mechanical means, but only by exercise of intelligence, care, and common sense. It is therefore essential to have personnel involved in the use and operation of equipment who are careful, competent, trained, and qualified in the safe operation of this equipment and its proper use when servicing motor vehicles and their components. Examples of hazards are dropping, tipping, or slipping of motor vehicles or their components caused primarily by improperly securing loads, overloading, off-centered loads, use on other than hard level surfaces, and using equipment for a purpose for which it was not designed. Only American Forge & Foundry attachments and/or adapters may be used on this equipment.

The owner and / or operator shall study and understand the product and safety instructions before operating this equipment. Safety information shall be emphasized and understood. If the operator is not fluent in English, the product and safety instructions shall be read to and discussed with the operator in the operator's native language by the purchaser / owner or his designee, making sure that the operator comprehends their contents. A copy of these instructions / warnings shall be retained for future reference.

1. SERVICE / INSPECTION

Visual inspection shall be made before each use of this equipment and its adapters, checking for abnormal conditions, such as cracked welds, leaks, damaged, loose or missing parts. This equipment shall be removed immediately from service if it is believed to have been subjected to an abnormal or shock load, the equipment shall be inspected by a qualified repair facility. Owners and / or operators should be aware that repair of this equipment may require specialized knowledge and facilities. It is recommended that this equipment be inspected annually by a qualified repair facility. Defective parts, decals, safety labels or signs should be replaced with American Forge & Foundry specified parts.



WARNING!

- The hydraulic equipment operator must be a qualified operator with correct training and work experience operating hydraulic equipment. Lack of knowledge in any of these areas can lead to equipment damage or personal injury.
- Read, understand, and follow all instructions before operating this jack.
- Inspect the jack before each use. Do not use jack if damaged, altered, modified, leaking hydraulic fluid or with missing or loose components.
- To avoid personal injury, never modify or weld hydraulic equipment.
- Never lift more than the rated capacity of the jack, overloading causes equipment failure and possible personal injury.
- The jack is a load lifting device, not a load holding device. Once the load has been positioned, it must be supported mechanically. Never work under, or around a load solely supported by hydraulic means.
- Never put unbalanced or off-center loads on the jack saddle. Do not use saddle adapters or saddle extenders between the stock lifting saddle and the load. Incorrect loading can result in equipment failure.
- Do not move or dolly the vehicle while on the jack.
- Always wear safety glasses and/or other protective equipment that meet or exceed ANSI Z87.1 and OSHA standards.
- Use the jack ONLY on hard, level surfaces capable of sustaining the load.



IMPORTANT

- Keep the air/ hydraulic jack clean at all time. When the air/ hydraulic jack is not in use, release the valve and disconnect the air hose.
- Use hydraulic equipment in normal operating temperatures. Do not use equipment in temperatures of 65° C (150° C) or higher. Overheating will soften seals and weakens hose material, resulting in fluid leaking or other equipment failure.

2. DESCRIPTION

The air/hydraulic jacks are designed for fleet truck shops, farm equipment dealers, bus company garages and military repair facilities.

Specifications

Model	3225	Model	3225
Capacity (Tons)	20	Max. Height (in.)	26.375
Chassis Height (in.)	11.29	Min. Height (in.)	7.5
Chassis Length (in.)	65.7	Overall Width (in.)	19.6
Handle Length (in.)	45.47	Net Weight (lbs.)	562

3. Set Up

Please refer to the parts list in this manual in order to identify parts.

1. Loosen the bolt item #1-39 on the handle socket item #1-37.
2. Install the handle assembly item #2-8 in the handle socket item #1-37; please align the main handle tube with the largest hole in the handle socket and the Control Rod with the smaller hole in the handle socket. When you install the handle in the socket, please make sure the Control Rod is in the down/lock position (position B).
3. Once the main handle tube and Control Rod are aligned with their respective holes in the handle socket, push the handle assembly in the handle socket so the end of the handle tube engages the release valve mechanism in the bottom of the handle socket and the Control Rod engages one of the three (3) locking holes in the jack frame.
4. Disengage the Control Rod by pulling up on the lever (Position A) and engaging the lever with the slot in top of the handle assembly. The handle assembly should be free to pump up and down.

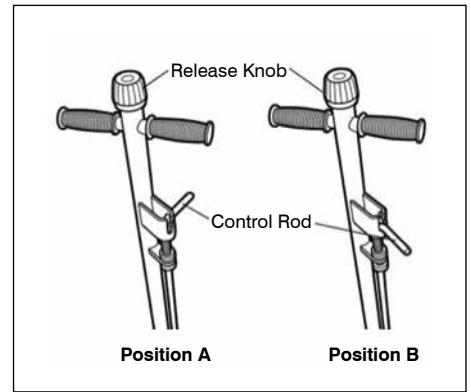

IMPORTANT

Once handle assembly into the handle socket is complete, turn the release valve knob at the top of the handle left and right to see if the release valve U-joint in front and below the handle socket is rotating simultaneously with the turning of the knob.

4. BLEEDING AIR

Before use: Air may accumulate within a jack during shipment or after prolonged use; this air can cause the jack to work incorrectly, Please use the steps below to bleed the air from the jack:

STEP 1

With the release valve knob in the closed position, turn the knob in counterclockwise direction 2 or 3 complete revolutions. Depress the foot pedal about 20 times.

STEP 2

Close the release valve knob by turning it in a clockwise direction until it stops. Depress the air valve lever about 10 times and hold it down on the last depression. If the jack's lift arm will not rise, repeat steps 1 and 2 again.

STEP 3

If depressing the air valve will not raise the lift arm, close the release valve knob by turning it clockwise until it stops. Depress the foot pedal to raise the lift arm to its maximum height. Depress the air valve while quickly turning the release valve 2 to 3 revolutions in a counterclockwise direction. The lift arm should lower rapidly. Close the release valve knob by turning it clockwise direction until it stops. Depress the air valve to see if lift arm will rise. If not, repeat step 3 several times to achieve maximum performance.

5. OPERATING INSTRUCTIONS

Control Rod in Position A: Allows you to pump the jack using the handle.

Control Rod in Position B: Locks the handle in place in three different positions.

- Connect the shop air supply to the jack. (Shop air should be clean, dry, and regulated at 90-120 PSI.)
- Turn release knob completely counterclockwise, and place the control rod in Position A.
- Position the jack under the vehicle using the manufacturer's recommended lifting points on the chassis.
- Turn the release knob on the jack completely clockwise to operate the air valve, pump the jack handle. Or pump the foot pedal until the saddle touches the vehicle. Check the placement of the saddle, continue lifting the vehicle.
- Place approved safety stands under the vehicle at points that will provide stable support. Before working on the vehicle, SLOWLY lower the vehicle onto the safety stands by turning the release knob counterclockwise.

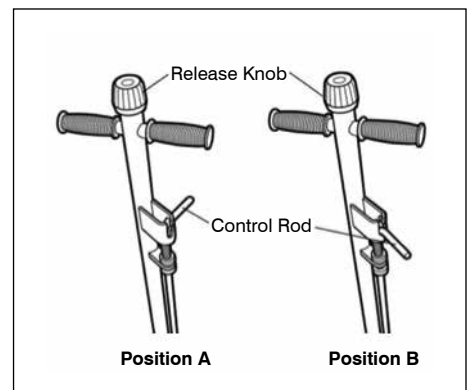

6. MAINTENANCE

IMPORTANT: Dirt is the greatest single cause of failure in hydraulic units.

Keep the service jack clean and well lubricated to prevent dirt from entering the air or hydraulic systems. If the jack has been exposed to rain, snow, sand, or grit, it must be cleaned before use.

- Store the jack in a well-protected area where it will not be exposed to moisture, corrosive vapors, abrasive dust, or any other harmful elements.
- Refer to the illustration, and regularly lubricate (at least once per month) the moving parts shown.
- Add grease to upper arm grease nipple (shown) every three months.
- If necessary, add approved anti-wear hydraulic jack oil. **IMPORTANT:** The use of alcohol, hydraulic brake fluid, detergent motor oil, or transmission oil could damage the seals and result in jack failure.
- Inspect the jack before each use. Take corrective action if any of the following problems are found:
 - a. cracked or damaged housing
 - b. excessive wear, bending, or other damage
 - c. leaking hydraulic fluid
 - d. scored or damaged piston rod
 - e. malfunctioning swivel heads or adjusting screws
 - f. loose hardware
 - g. modified or altered equipment

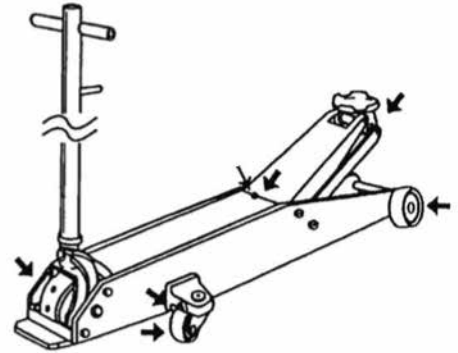

7. TROUBLESHOOTING

Repair procedures must be performed in a dirt free environment by qualified personnel who are familiar with this equipment.

Trouble	Cause	Solution
Jack does not lift	<ol style="list-style-type: none"> 1. Release valve is open. 2. Low/no oil in reservoir. 3. Air-locked system. 4. Load is above capacity of jack. 5. Delivery valve and/or bypass valve not working correctly. 6. Packing worn out or defective. 7. Leak in air line. 8. Inadequate air pressure. 	<ol style="list-style-type: none"> 1. Close release valve. 2. Fill with oil and bleed system. 3. Bleed system. 4. Use correct equipment. 5. Clean to remove dirt or foreign matter. 6. Install seal kit. 7. Locate leak, tighten connections or replace hose. 8. Set air pressure to 90-120 PSI.
Jack lifts only partially	<ol style="list-style-type: none"> 1. Too much or not enough oil. 	<ol style="list-style-type: none"> 1. Check oil level.
Jack advances slowly	<ol style="list-style-type: none"> 1. Pump not working correctly. 	<ol style="list-style-type: none"> 1. Install seal kit, or replace power unit.
Jack lifts load, but doesn't hold	<ol style="list-style-type: none"> 1. Cylinder packing is leaking. 2. Valve not working correctly (suction, delivery, release, or bypass). 3. Air-locked system. 	<ol style="list-style-type: none"> 1. Install seal kit. 2. Inspect valves. Clean and repair seat surfaces. 3. Bleed system.
Jack leaks oil	<ol style="list-style-type: none"> 1. Worn or damaged seals. 	<ol style="list-style-type: none"> 1. Install seal kit.
Jack will not retract	<ol style="list-style-type: none"> 1. Release valve is closed. 	<ol style="list-style-type: none"> 1. Open or clean release valve.
Air motor won't run or runs erratically	<ol style="list-style-type: none"> 1. Leak in air line. 2. Inadequate air pressure. 	<ol style="list-style-type: none"> 1. Locate leak, tighten connections, or replace hose. 2. Set air pressure to 90-120 PSI.



Parts List

20 Ton Air/Hydraulic Service Jack

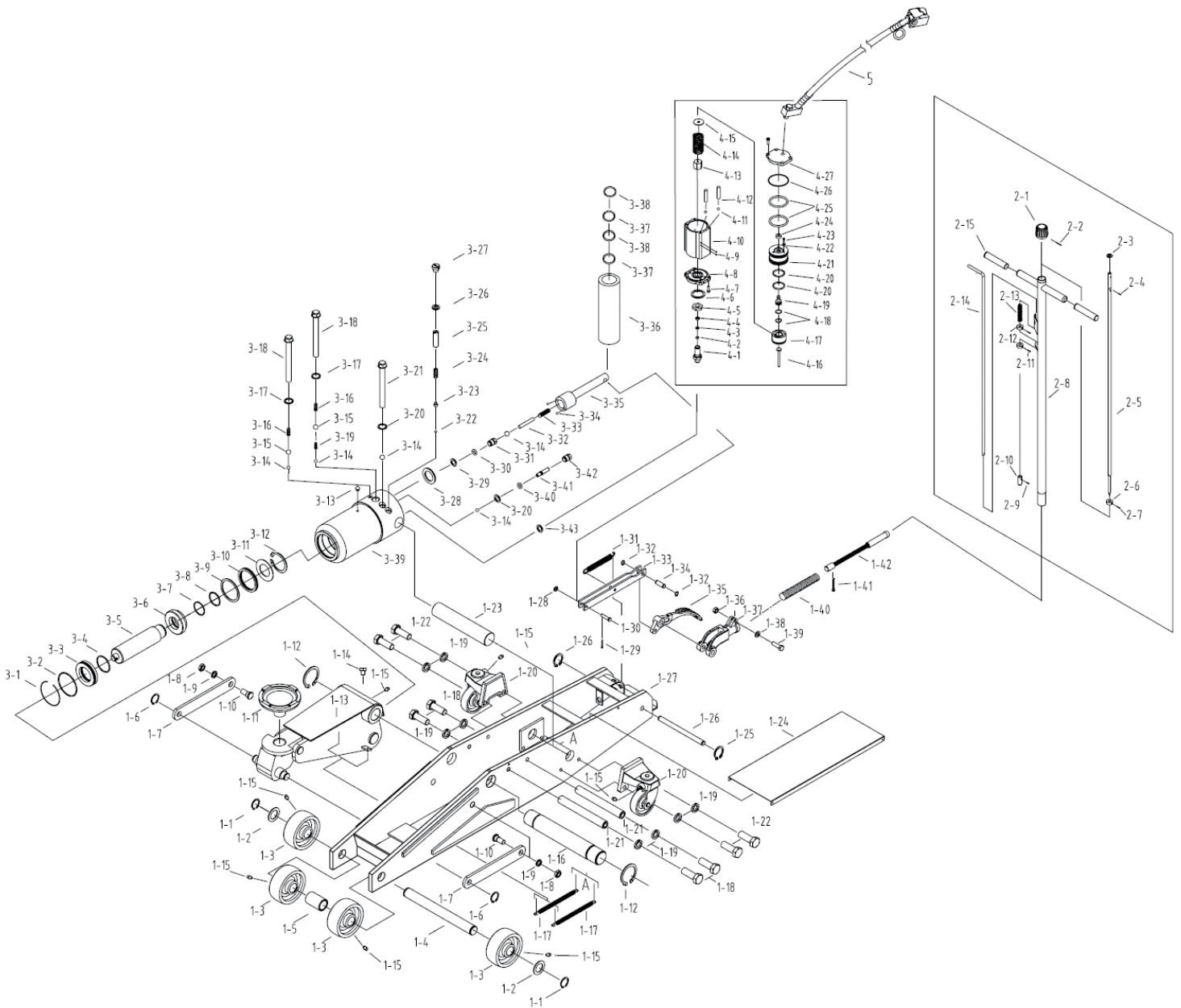



Ref.	Part Number	Description	Req.
1-1	PTL-980P1-1	Snap Ring	2
1-2	PTL-980P1-2	Washer	2
1-3	PTL-980P1-3	Front Wheel	4
1-4	PTL-980P1-4	Front Wheel Axle	1
1-5	PTL-980P1-5	Bush	1
1-6	PTL-980P1-6	Snap Ring	2
1-7	PTL-980P1-7	Link Ring	2
1-8	PTL-980P1-8	Nut	2
1-9	PTL-980P1-9	Washer	2
1-10	PTL-980P1-10	Bolt	2
1-11	PTL-980P1-11	Saddle	1
1-12	PTL-980P1-12	Snap Ring	2
1-13	PTL-980P1-13	Lift Arm	1
1-14	PTL-980P1-14	Bolt	1
1-15	PTL-980P1-15	Grease Fitting	7
1-16	PTL-980P1-16	Pin	1
1-17	PTL-980P1-17	Spring	2
1-18	PTL-980P1-18	Bolt	4
1-19	PTL-980P1-19	Wahser	8
1-20	PTL-980P1-20	Rear Wheel Assembly	2
1-21	PTL-980P1-21	Bush	2
1-22	PTL-980P1-22	Bolt	4
1-23	PTL-980P1-23	Pin	1
1-24	PTL-980P1-24	Cover	1
1-25	PTL-980P1-25	Snap Ring	2
1-26	PTL-980P1-26	Pin	1
1-27	PTL-980P1-27	Frame	1
1-28	PTL-980P1-28	Washer	1
1-29	PTL-980P1-29	Pin	1
1-30	PTL-980P1-30	Pin	1
1-31	PTL-980P1-31	Spring	1
1-32	PTL-980P1-32	Washer	2
1-33	PTL-980P1-33	Link Assembly	1
1-34	PTL-980P1-34	Pin	1
1-35	PTL-980P1-35	Pedal	1
1-36	PTL-980P1-36	Nut	1
1-37	PTL-980P1-37	Handle Socket	1
1-38	PTL-980P1-38	Washer	1
1-39	PTL-980P1-39	Bolt	1
1-40	PTL-980P1-40	Spring	1
1-41	PTL-980P1-41	Bolt	1
1-42	PTL-980P1-42	Release Assembly	1
1-43	PTL-980P1-43	Fix Ring	1
1-44	PTL-980P1-44	Washer	1
1-45	PTL-980P1-45	Washer	1
1-46	PTL-980P1-46	Bolt	1

Ref.	Part Number	Description	Req.
2-1	PTL-980P2-1	Knob	1
2-2	PTL-980P2-2	Pin	1
2-3	PTL-980P2-3	Washer	1
2-4	PTL-980P2-4	Pin	1
2-5	PTL-980P2-5	Rod	1
2-6	PTL-980P2-6	Washer	1
2-7	PTL-980P2-7	Pin	1
2-8	PTL-980P2-8	Handle Tube	1
2-9	PTL-980P2-9	Pin	1
2-10	PTL-980P2-10	Pin	1
2-11	PTL-980P2-11	Bolt	2
2-12	PTL-980P2-12	Washer	2
2-13	PTL-980P2-13	Spring	1
2-14	PTL-980P2-14	Control Rod	1
2-15	PTL-980P2-15	Sleeve	2
3-1	PTL-980P3-1	Snap Ring	1
3-2	PTL-980P3-2	O-Ring	1
3-3	PTL-980P3-3	Ring	1
3-4	PTL-980P3-4	O-Ring	1
3-5	PTL-980P3-5	Piston	1
3-6	PTL-980P3-6	Piston Ring	1
3-7	PTL-980P3-7	Gasket	1
3-8	PTL-980P3-8	O-Ring	1
3-9	PTL-980P3-9	Piston Washer	1
3-10	PTL-980P3-10	Seal	1
3-11	PTL-980P3-11	Piston Washer	1
3-12	PTL-980P3-12	Snap Ring	1
3-13	PTL-980P3-13	Plug	1
3-14	PTL-980P3-14	Steel Ball	5
3-15	PTL-980P3-15	Steel Ball	2
3-16	PTL-980P3-16	Spring	2
3-17	PTL-980P3-17	Copper Washer	2
3-18	PTL-980P3-18	Bolt	2
3-19	PTL-980P3-19	Spring	1
3-20	PTL-980P3-20	Copper Washer	2
3-21	PTL-980P3-21	Bolt	1
3-22	PTL-980P3-22	Steel Ball	1
3-23	PTL-980P3-23	Ball Seat	1
3-24	PTL-980P3-24	Spring	1
3-25	PTL-980P3-25	Bolt	1
3-26	PTL-980P3-26	Seal	1
3-27	PTL-980P3-27	Bolt	1
3-28	PTL-980P3-28	Copper Washer	1
3-29	PTL-980P3-29	O-Ring	1
3-30	PTL-980P3-30	O-Ring	1
3-31	PTL-980P3-31	Bolt	1

Ref.	Part Number	Description	Req.
3-32	PTL-980P3-32	Rubber Seal	1
3-33	PTL-980P3-33	Spring	1
3-34	PTL-980P3-34	Steel Ball	2
3-35	PTL-980P3-35	Pump Piston	1
3-36	PTL-980P3-36	Piston House	1
3-37	PTL-980P3-37	O-Ring	2
3-38	PTL-980P3-38	Snap Ring	2
3-39	PTL-980P3-39	Pump Cylinder	1
3-40	PTL-980P3-40	O-Ring	1
3-41	PTL-980P3-41	Release Rod	1
3-42	PTL-980P3-42	Fix Ring	1
3-43	PTL-980P3-43	Copper Washer	1
4-1	PTL-980P4-1	Pump Cylinder	1
4-2	PTL-980P4-2	Seal	1
4-3	PTL-980P4-3	Nylon Gasket	1
4-4	PTL-980P4-4	Copper Ring	1
4-5	PTL-980P4-5	Nut	1
4-6	PTL-980P4-6	Spring	1
4-7	PTL-980P4-7	Bolt	8
4-8	PTL-980P4-8	Front Cover	1
4-9	PTL-980P4-9	Steel Ball	4
4-10	PTL-980P4-10	Air Pump Housing	1
4-11	PTL-980P4-11	Steel Ball	2
4-12	PTL-980P4-12	Pin	2
4-13	PTL-980P4-13	Nut	1
4-14	PTL-980P4-14	Spring	1
4-15	PTL-980P4-15	Washer	1
4-16	PTL-980P4-16	Cylinder Pump Plunger	1
4-17	PTL-980P4-17	Piston	1
4-18	PTL-980P4-18	O-Ring	2
4-19	PTL-980P4-19	Air Release Rod	1
4-20	PTL-980P4-20	O-Ring	2
4-21	PTL-980P4-21	Piston	1
4-22	PTL-980P4-22	O-Ring	3
4-23	PTL-980P4-23	Bolt	3
4-24	PTL-980P4-24	Air Seal	1
4-25	PTL-980P4-25	O-Ring	2
4-26	PTL-980P4-26	O-Ring	1
4-27	PTL-980P4-27	Rear Cover	1
5	PTL-980P5	Air Hose Assembly	1
NS	PTL-980PPU	Power Unit	1
NS	PTL-980P-AM	Air Motor Assembly	1
NS	PTL-980P-HA	Handle Assembly	1
NS	PTL-980P-HRK	Hydraulic Repair Kit	1



MODEL 3225 - 20 TON FLOOR JACK

PART ORDER NUMBER	KIT DESCRIPTION	KIT INCLUDES	
		REF. #	DESCRIPTION
3225K28	HANDLE COMPLETE	2-8	HANDLE ASSEMBLY
3220K141	SCREW	1-42	SCREW
3225K339	HYDRAULIC UNIT	3-39	HYDRAULIC UNIT
3225KRK	REPAIR KIT		REPAIR KIT
3220K120	REAR WHEEL	1-20	REAR WHEEL ASSEMBLY
3220K13	FRONT WHEEL	1-1 1-2 1-3	SNAP RING WASHER WHEEL
3220K111	SADDLE	1-11	SADDLE
3220K117	SPRING	1-17	SPRING
3220K131	SPRING	1-31	SPRING
3220K142	UNIVERSAL	1-42	UNIVERSAL
3220K140	SPRING	1-40	SPRING
3220K215	RUBBER GRIPS	2-15	RUBBER GRIPS FOR HANDLE
3220K137	HANDLE SOCKET KIT	1-37 1-36 1-38 1-39	SOCKET NUT SNAP RING BOLT
3220K135	PEDAL	1-35	FOOT PEDAL
3220K133	CONNECTION BAR	1-33	CONNECTION BAR
3220K17	ROD LINK	1-7	ROD LINK
3225K410	AIR PUMP	4-10	AIR PUMP COMPLETE
3225K5	AIR HOSE	5	AIR HOSE COMPLETE



MODEL 3225 - 20 TON FLOOR JACK

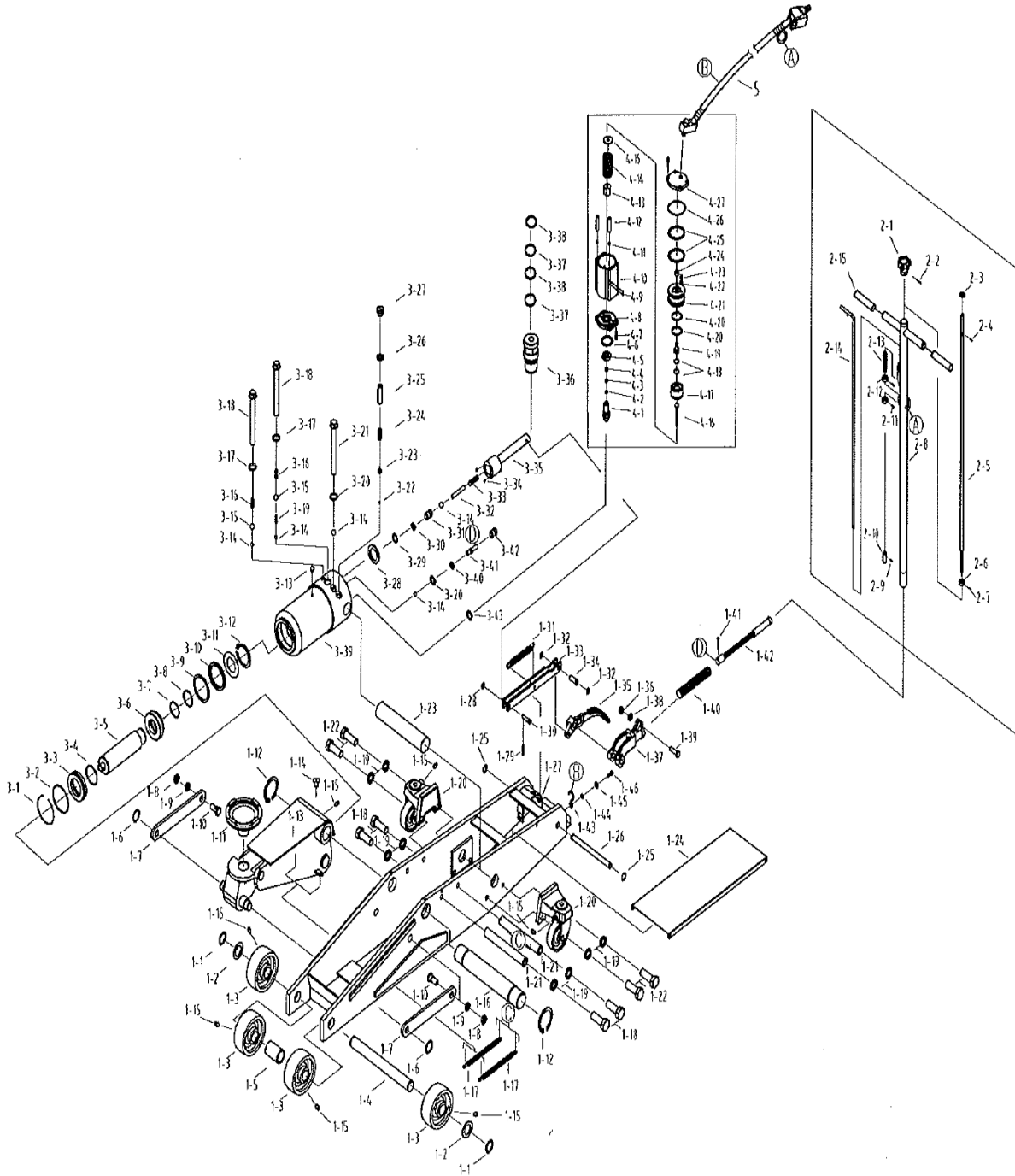

*** ONLY PARTS WITH A "PART ORDER NUMBER" ARE AVAILABLE FOR SALE.
DO NOT COPY OR DISTRIBUTE THIS MATERIAL WITHOUT PERMISSION OF AFF, INC.**



AMERICANFORGE&FOUNDRY™

Heavy Duty 20 Ton Long Chassis Jacks **MODELS 3220 & 3225**

- ✓ Ideal for truck tire and repair shops, fleet service, maintenance shops, military bases, and job sites
- ✓ Heavy duty pumps, rams, and cylinders are precision machined and inspected to ensure long service life and superior performance
- ✓ Super long 66" body for easier lifting of vehicles with long overhangs
- ✓ Handle mounted locking control lever locks handle in one of three positions: vertical, 45°, or horizontal for better versatility
- ✓ Foot operated pump for quick lifting efficiency
- ✓ Automatic overload safety valve for added safety
- ✓ Air motor on model 3225 designed for use with compressed air system between 90-120 PSI



MODEL	CAPACITY (tons)	TYPE	LOW HEIGHT	HIGH HEIGHT	LIFT HEIGHT	CHASSIS LENGTH	OVERALL WIDTH (front)	OVERALL WIDTH (rear)	PRODUCT WEIGHT (lbs)
3220	20	Manual	7.500"	26.375"	18.875"	66.000"	13.800"	19.700"	530
3225	20	Air Assist	7.500"	26.375"	18.875"	66.000"	13.800"	19.700"	562

When it comes to quality car jacks, AFF is the brand you can depend on.