



AMERICAN FORGE & FOUNDRY, INC.™

1.5 TON / 2 TON / 3 TON ALUMINUM RACING JACKS

Models 206, 208, 210

AFF's "1 - 2 - 3 - PUNCH" rounds out our Automotive Floor Jack lineup with a complete line of Aluminum Service Jacks - Lightweight, Rugged and Super Fast all three of these new models comes with a Double Pump Plunger design to get the car in the air and the job done quickly.

206 - 1.5 Ton



208 - 2 Ton

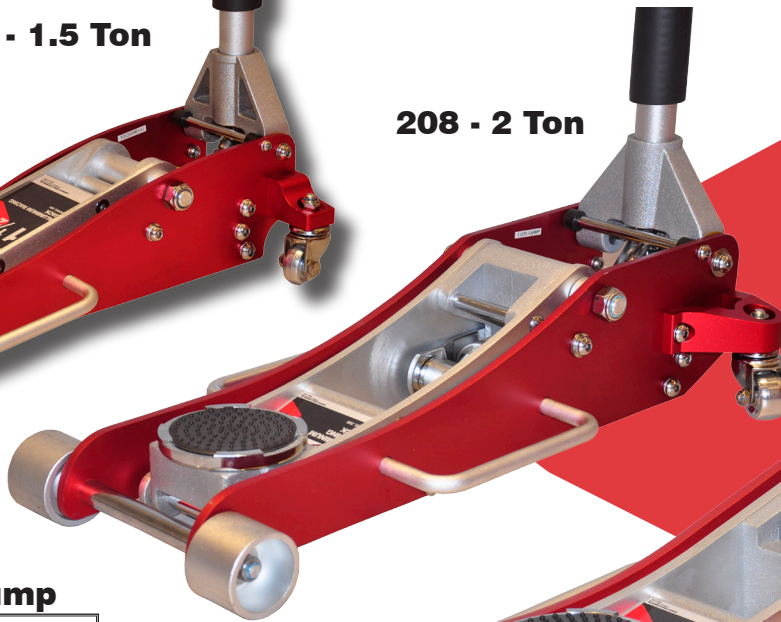

210 - 3 Ton

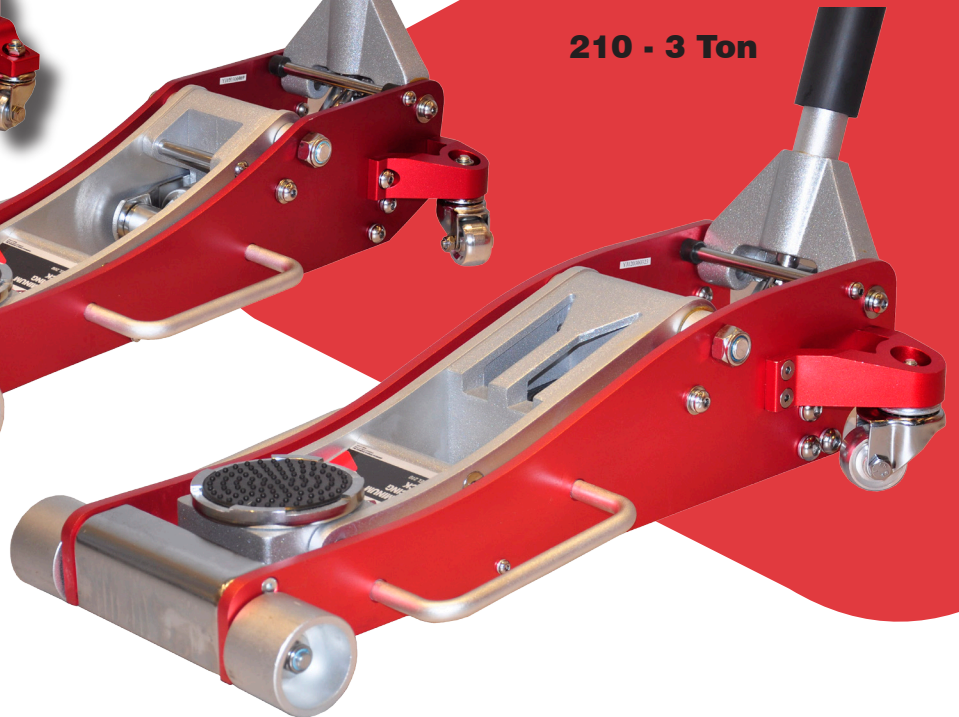

Double Pump

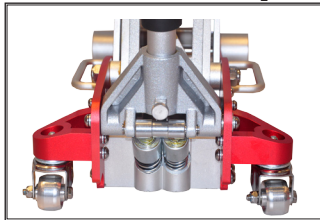

SPECIFICATIONS

Model 206 - 1.5 Ton Aluminum Racing Jack

- Double Pump Design
- Padded 2 Pc. Handle
- Padded Saddle
- Side Handle
- Front Roller

Low Height 3.25"
 High Height 15"
 Length 20.75"
 Width (widest) 10"
 Net Weight 26 lbs.
 Gross Weight 30 lbs.

Model 208 - 2 Ton Aluminum Racing Jack

- Double Pump Design
- Padded 2 Pc. Handle
- Padded Saddle
- 2 Side Handles
- Front Wheels

Low Height 3.5"
 High Height 18.5"
 Length 25.75"
 Width (widest) 11.75"
 Net Weight 43 lbs.
 Gross Weight 46 lbs.

Model 210 - 3 Ton Aluminum Racing Jack

- Double Pump Design
- Padded 2 Pc. Handle
- Padded Saddle
- 2 Side Handles
- Front Wheels

Low Height 3.75"
 High Height 19.3"
 Length 26"
 Width (widest) 14"
 Net Weight 55 lbs.
 Gross Weight 58 lbs.

Check out the collection of car jacks we offer.