



**AMERICAN FORGE & FOUNDRY, INC.™**

## 2 TON PROFESSIONAL DUTY “TUNER” SERVICE JACK

Model 200T

AFF 200 Pro-Series Floor Jacks are designed to meet the lifting needs required for low profile “Tuner” and high performance vehicles. Similar to the AFF 350 Series, the 200T incorporates a safety overload valve for added protection and is built to meet ANSI standards for performance and safety.

- Our Model 200T floor jack is built with our traditional AFF quality, perfect for today’s lower-profile “tuner” vehicles. It quickly lifts from a low 2-3/4” to 20” with AFF’s double-pumper advantage (see inset).
- Universal joint technology and precision release valve for a more controlled release
- Pinned steel saddle (1” stud) with rubber pad for added vehicle protection
- Tough UV powder-coated frame for greater protection and durability
- One-piece, foam-covered 50” handle for ease of positioning, pumping and storage



### RELATED PRODUCTS



**Model 3907**  
Pneumatic Creeper Seat



**Model 350SS**  
3 1/2 Ton Professional Service Jack



**Model SS6**  
6 Ton Ratchet Style Safety Stands



# MODEL 200T - 2 TON LOW-PROFILE JACK

PART ORDER NUMBER	KIT DESCRIPTION	KIT INCLUDES	
		REF. #	DESCRIPTION
200TK03	WHEEL KIT	1	RETAINING RING
		2	WASHER
		3	WHEEL
200TK20	HANDLE COMPLETE	20	HANDLE
		40	HANDLE PADDING
200TK40	PADDING	40	HANDLE PADDING
200TK7C	CASTER COMPLETE	7	CASTER ASSEMBLY
		12	NUT M18
		13	SPRING WASHER M18
200TKRK	REPAIR KIT	H3	O-RING
		H4	O-RING
		H5	RETAINING RING
		H7	O-RING
		H9	SAFTEY VALVE
		H10	RELIEF VALVE SPRING
		H12	O-RING (2 REQUIRED)
		H14	O-RING
		H14-1	SEAL RING
		H15	SEAL WASHER
		H25	O-RING
		H26	BALL 6mm
		H28	O-RING
		H29	O-RING
		H29-1	SEAL RING
		H31	BALL 10mm (2 REQUIRED)
		H32	BALL 8mm (2 REQUIRED)
		H33	SEPARATOR (2 REQUIRED)
		H34	BALL 5.5 mm (2 REQUIRED)
		H35	SAFTEY VALVE
		H36	RELIEF VALVE SPRING
H37	SEAL RING (2 REQUIRED)		
H38	O-RING (2 REQUIRED)		
H39	SEAL WASHER		
H41	OIL STRAINER (2 REQUIRED)		
H42	O-RING		
200TKHU	HYDRAULIC UNIT	21	HYDRAULIC UNIT ASSEMBLY
200TK32	SADDLE COMPLETE	32	SADDLE COMPLETE WITH PAD
		42	SADDLE PAD
		43	RETAINING PIN
200TK42	PAD	42	SADDLE PAD
200TK15	HANDLE SPRING	15	TORSION SPRING

**DO NOT COPY OR DISTRIBUTE THIS MATERIAL WITHOUT PERMISSION OF AFF, INC.**



# MODEL 200T - 2 TON LOW-PROFILE JACK

PART ORDER NUMBER	KIT DESCRIPTION	KIT INCLUDES	
		REF. #	DESCRIPTION
200TK17	BOLT	17	HANDLE RETAINING BOLT
200TKH16	PRESSURE PUMP ASSEMBLY	H14 H14-1 H15 H16 H17 H18 H19 H20 H21 H22	O-RING SEALING RING SEALING WASHER PUMP CORE PUMP CASE PUMP INNER CASE PRESS SPRING PUMP OUTER CASE PUMP COVER PIN 4X30
200TKH27	VOLUME PUMP ASSEMBLY	H18 H19 H20 H21 H22 H23 H27 H28 H29 H29-1	PUMP INNER CASE PRESS SPRING PUMP OUTER CASE PUMP COVER PIN 4X30 PUMP CASE PUMP CORE O-RING O-RING SEAL RING
200TKH24	RELEASE VALVE	H24	RELEASE VALVE ASSEMBLY
NOT AVAILABLE SEPARATELY		4	SIDE PLATE ASSY.
NOT AVAILABLE SEPARATELY		5	WASHER M16
NOT AVAILABLE SEPARATELY		6	HEX NUT M16
NOT AVAILABLE SEPARATELY		8	HEX NUT M12 X 20
NOT AVAILABLE SEPARATELY		9	SPRING WASHER
NOT AVAILABLE SEPARATELY		10	BOLT
NOT AVAILABLE SEPARATELY		11	SPRING WASHER
NOT AVAILABLE SEPARATELY		14	SCREW
NOT AVAILABLE SEPARATELY		16	HANDLE SOCKET
NOT AVAILABLE SEPARATELY		22	SPRING
NOT AVAILABLE SEPARATELY		23	INSPECTION PLATE
NOT AVAILABLE SEPARATELY		24	HEX NUT M24
NOT AVAILABLE SEPARATELY		25	SHAFT ARM
NOT AVAILABLE SEPARATELY		26	BOLT
NOT AVAILABLE SEPARATELY		27	RETAINING RING M24
NOT AVAILABLE SEPARATELY		28	LONG LINKAGE
NOT AVAILABLE SEPARATELY		29	BLOCK LINKAGE
NOT AVAILABLE SEPARATELY		30	RETAINING RING M10
NOT AVAILABLE SEPARATELY		31	SADDLE BLOCK
NOT AVAILABLE SEPARATELY		34	WASHER M24
NOT AVAILABLE SEPARATELY		36	PULL ROD
NOT AVAILABLE SEPARATELY		37	WASHER M8
NOT AVAILABLE SEPARATELY		38	NUT M8
NOT AVAILABLE SEPARATELY		39	LIFT ARM ASSEMBLY
NOT AVAILABLE SEPARATELY		41	SPLIT PIN

**DO NOT COPY OR DISTRIBUTE THIS MATERIAL WITHOUT PERMISSION OF AFF, INC.**

## PARTS LIST

NO.	DESCRIPTION	QTY	NO.	DESCRIPTION	QTY
1	Retaining Ring	2	23	Inspection Plate	1
2	Washer	2	24	Hex Nut 22	2
3	Wheel	2	25	Shaft Arm	1
4	Side Plate Assy	1	26	Bolt	2
5	Washer 16	2	27	Retaining Ring 25	2
6	Hex Nut M16	2	28	Long Linkage	2
7	Caster Assembly	2	29	Block Linkage	1
8	Hex Bolt M12x20	2	30	Retaining Ring 10	2
9	Spring Washer	2	31	Saddle Block	1
10	Bolt	2	32	Saddle	1
11	Spring Washer	2	33	Linkage Axle	1
12	Nut M18	2	34	Washer 22	2
13	Spring Washer 18	2	35	Foot Pedal	1
14	Screws	4	36	Pull Rod	1
15	Torsion Spring	2	37	Washer 8	2
16	Handle Socket	1	38	Nut M8	2
17	Bolt	1	39	Lift Arm Assembly	1
18		1	40	Handle Bumper	1
19		1	41	Split Pin 4x25	1
20	Handle Lower	1	42	Rubber Saddle Pad	1
21	Power Unit Assy	1	43	Retaining Ring	1
22	Spring	1			

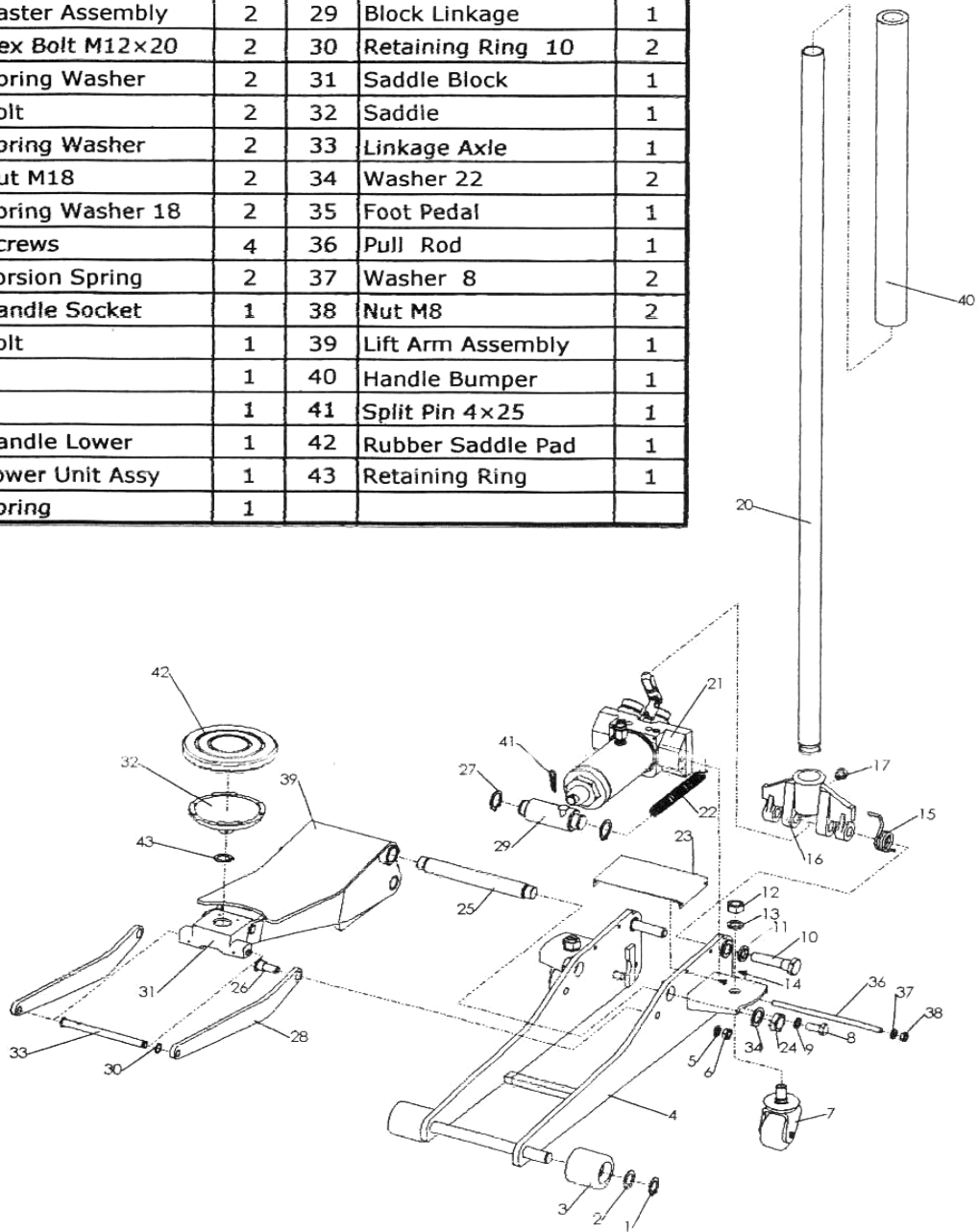

**DO NOT COPY OR DISTRIBUTE THIS MATERIAL WITHOUT PERMISSION OF AFF, INC.**

## PARTS LIST

NO.	DESCRIPTIN	QTY	NO.	DESCRIPTIN	QTY	NO.	DESCRIPTIN	QTY
H1	RAM	1	H17	PUMP CASE	1	H33	SEPARATOR	2
H2	RAM HEADER	1	H18	PUMP INNER CASE	2	H34	BALL 5.5	2
H3	O-RING RETURNER	1	H19	PRESS SPRING	2	H35	SAFETY VALVE	1
H4	O-RING	1	H20	PUMP OUTER CASE	2	H36	RELIEF VALVE SPRING	1
H5	RETAINING RING	1	H21	PUMP COVER	2	H37	WASHER	2
H6	CYLINDER	1	H22	PIN 4×30	2	H38	O-RING	2
H7	O-RING	1	H23	PUMP CASE	1	H39	SEAL WASHER	1
H8	VALVE BASE	1	H24	RELEASE ASSEMBLY	1	H40	CYLINDER OUTER CASE	1
H9	SAFETY VALVE	1	H25	O-RING	1	H41	OIL STRAINER	2
H10	RELIEF VALVE SPRING	1	H26	BALL 6	1	H42	O-RING	1
H11	REGULATE BALT	2	H27	PUMP CORE	1	H43	TANK NUT	1
H12	SEAL WASHER	2	H28	O-RING	1	H44	PIN 4×35	1
H13	SEAL BOLT	2	H29	O-RING	1	H45	SEAL BOLT	1
H14	O-RING	1	H29-1	SEAL RING	1	H46	SCREW	1
H14-1	SEAL RING	1	H30	HIGH-PRESSURE BOLT	2	H47	SPRING WASHER	1
H15	SEALING WASHER	1	H31	BALL 10	2	H48	LOCKER	1
H16	PUMP CORE	1	H32	BALL 8	2			

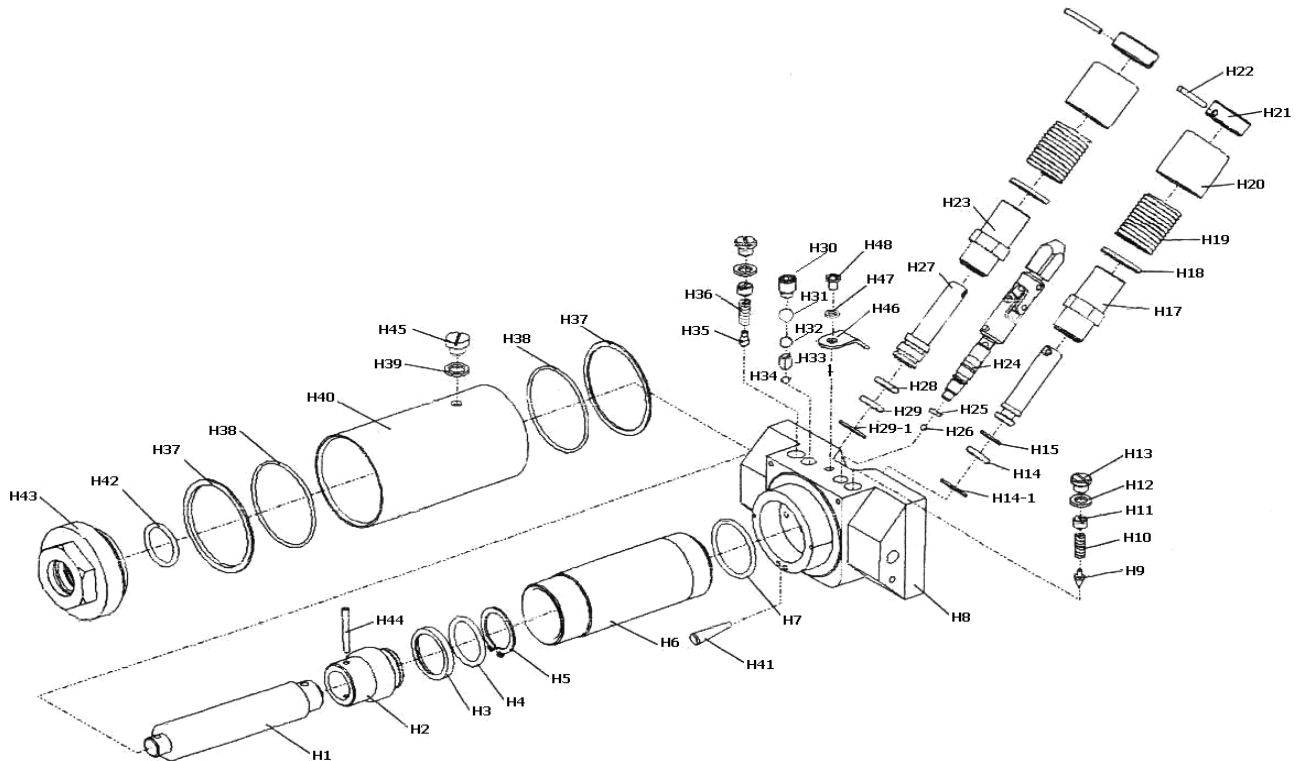

**DO NOT COPY OR DISTRIBUTE THIS MATERIAL WITHOUT PERMISSION OF AFF, INC.**

Rely on premium car jacks made by AFF if you're looking for quality and efficiency.