

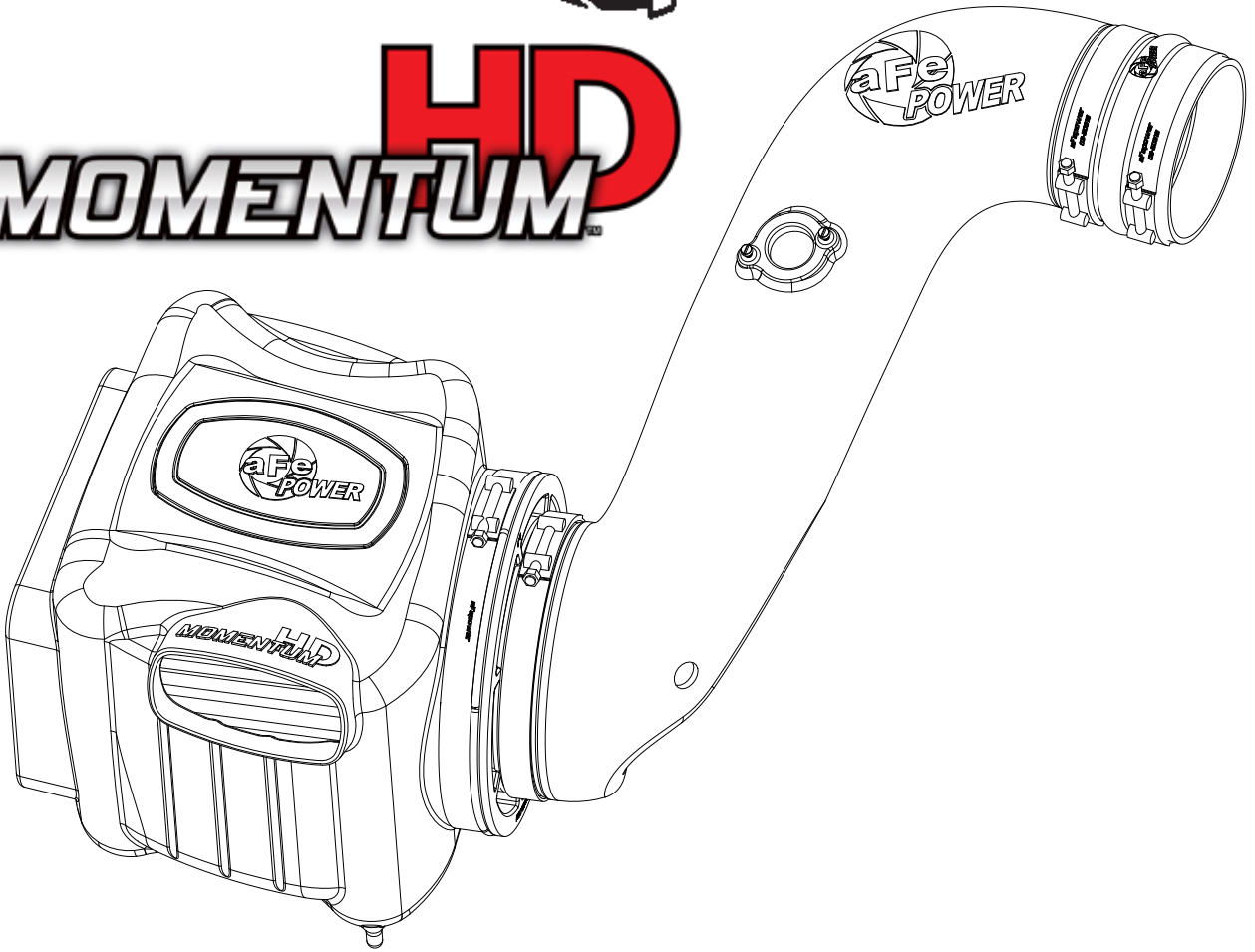

HD
MOMENTUM™



advanced ***FLOW*** engineering

Instruction Manual P/N: 50-74003

Make: **GM** Model: **Silverado/Sierra HD** Year: **2006-2007** Engine: **V8-6.6L (td) LLY/LBZ**



- Please read the entire instruction manual before proceeding.
- Ensure all components listed are present.
- Ensure you have all necessary tools before proceeding.
- Do not attempt to work on your vehicle when the engine is hot.
- Disconnect both the negative battery terminal before proceeding.
- Retain factory parts for future use.

Label	Qty.	Description	Part Number
A	1	Plug, Urethane	05-01202
B	1	Seal Trim - 26"	05-00072
C	1	Housing	05-74003B2
D	1	Clamp, T-bolt (8-5/16")	03-50267
E	1	PRO 10R (Blue Media)	20-91059
F	1	Tube	05-74003B1
G	2	Screw, M4	03-50034
H	2	Clamp, T-bolt (4-7/16")	03-50319
I	1	Coupling, Silicone Hump	05-01201
J	1	T20 Torx Bit	03-50066

Installation will require the following tools:

8mm Nut Driver, Flat Head Screw driver, 10mm Socket, Ratchet and Extension.

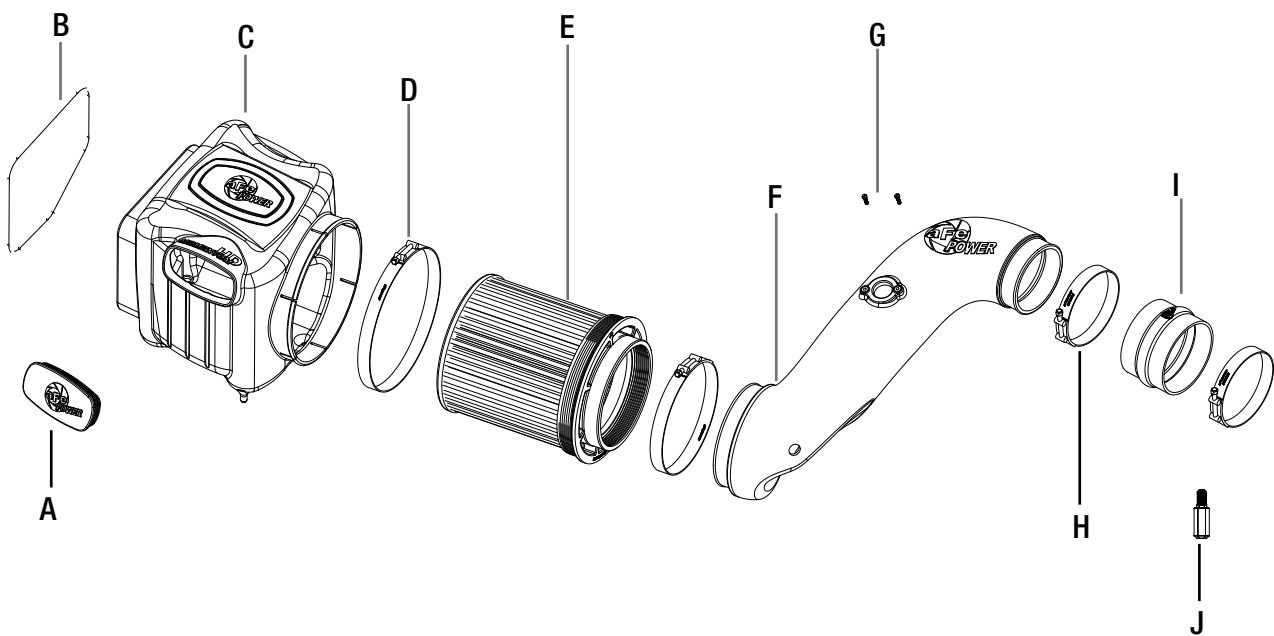

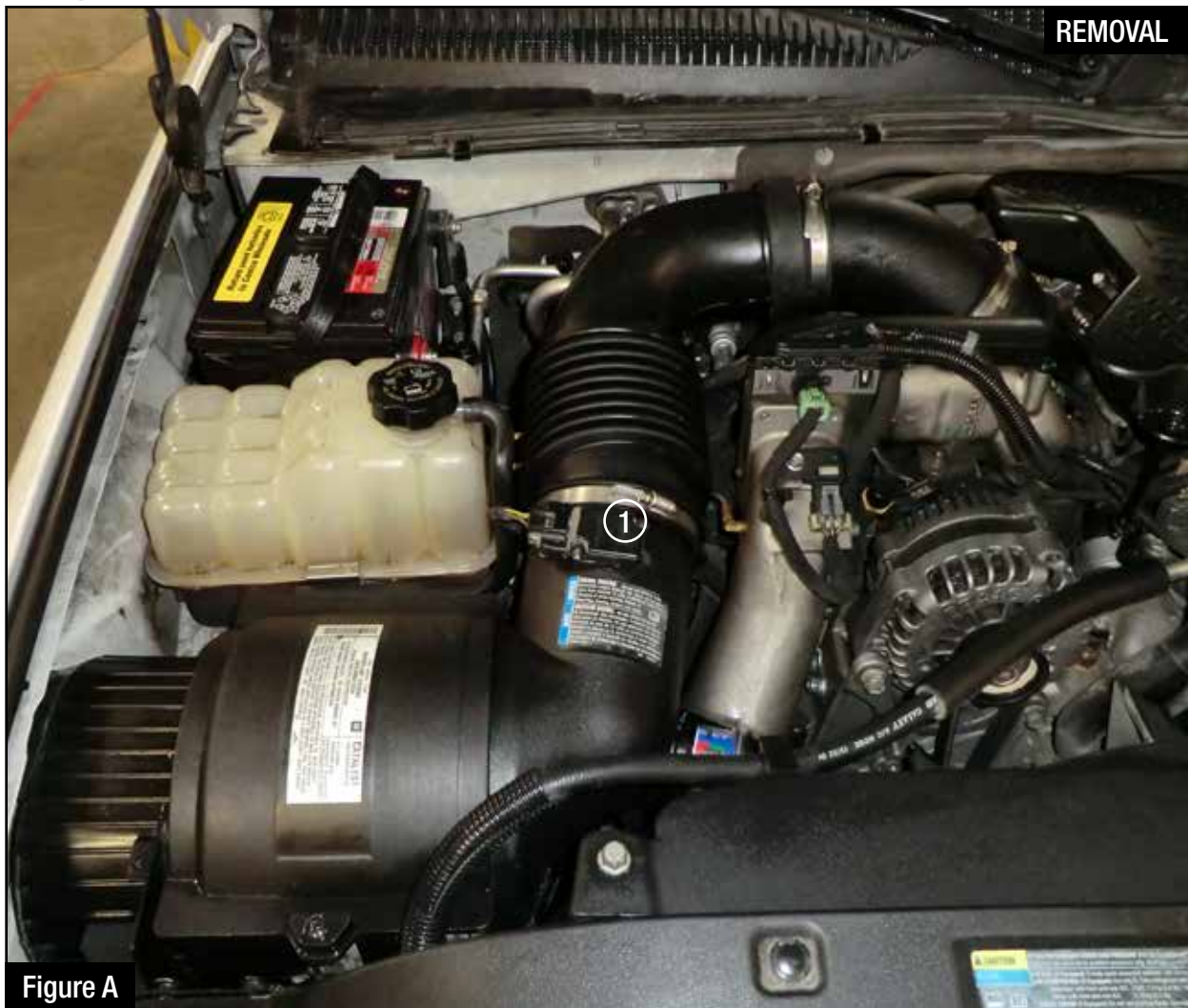
Figure A
Refer to Figure A for steps 1-4

Step 1: Disconnect both batteries.

Step 2: Disconnect Mass Air Flow sensor (MAF) ①.

Step 3: Loosen all intake tube clamps using a 8mm nut driver.

Step 4: Remove the factory intake tube and air box out of the vehicle. (Use an upward pull to release the air box from its mounting grommets)



Figure B

Refer to Figure B for step 5

NOTE: Wipe the filter flange with acetone to remove excess oil.

Step 5: Slide the air filter (E) into the air box (C). Install supplied T-bolt clamps (D) & (E).
(Do not tighten clamps at this time)

IMPORTANT: Prior to installation of T-bolt clamp, we recommend that you stretch the T-bolt clamps by installing it in its intended position and tightening.



Figure C

Refer to Figure C for steps 6 & 7

Step 6: Install the trim seal (B) on the edge of the Momentum HD air box.

Step 7: Remove the retaining plug (2) from the factory air box and install on the Momentum HD air box.

INSTALL



Figure D

Refer to Figure D for step 9

Step 9: Install the Momentum HD air box into the vehicle. Firmly push down into the factory mounting grommets.

Figure E
Refer to Figure E for steps 10-14

Step 10: Remove the MAF sensor (3) from the factory intake tube using T-20 torx bit.

Step 11: Remove the filter minder (4) and the grommet it sits in from the factory air box.

Step 12: Install the MAF sensor in the Momentum intake tube (F) using supplied screws (G).

Step 13: Install the factory grommet for the filter minder into the Momentum HD intake tube.

Firmly push the filter minder into the grommet on the intake tube to install it.

Step 14: Install the furnished silicone hump coupler (I) and the T-bolt clamps (H) on the Momentum HD intake tube. (Do not tighten clamps at this time)

**Figure F****Refer to Figure F for steps 15 & 16**

Step 15: Install the Momentum HD intake tube into the vehicle. Slide the coupling on to the turbo inlet first. Then rotate the tube down and slide it into the filter.

Step 16: Tighten all the T-bolt clamps.



Refer to Figure G for steps 17-19

Step 17: Reconnect the MAF sensor.

Step 18: Check all the components are tight and secured.

Step 19: Reconnect the batteries. Your installation is now complete.

Use the furnished plug (B) to close off the front auxiliary air inlet to completely seal the airbox.

NOTE: *Retighten all connections after approximately 100-200 miles.*