

advanced FLOW engineering

Instruction Manual P/N: TT-2016B / TT-2016L / TT-2016R



Make: **Scion** Model: **FR-S**

Make: **Subaru** Model: **BRZ**

Make: **Toyota** Model: **86/GT86/FT86**

Year: **2013-2016** Engine: **H4-2.0L**

Year: **2013-2019** Engine: **H4-2.0L (Includes tS)**

Year: **2012-2019** Engine: **H4-2.0L**



- Please read the entire instruction manual before proceeding.
- Ensure all components listed are present.
- If you are missing any of the components, call customer support.
- Ensure you have all necessary tools before proceeding.
- Do not attempt to work on your vehicle when the engine is hot.
- Disconnect the negative battery terminal before proceeding.
- Retain factory parts for future use.

Label	Qty.	Description	Part Number
A1	1	Tube	05-T2016B1 (Black)
A2	1	Tube	05-T2016L1 (Blue)
A3	1	Tube	05-T2016R1 (Red)
B	2	Clamp, #048	03-50007
C	1	Cap, Vinyl	03-50408
D	1	Clamp Mini, #024	03-50093

Installation will require the following tools:

Phillips screw driver, 8mm nut driver, ratchet, extension, 10mm/12mm socket & pliers

Note: Legal in California for use on race vehicles only. The use of this device on vehicles used on public streets or highways is strictly prohibited in California and others states that have adopted California emission regulations.

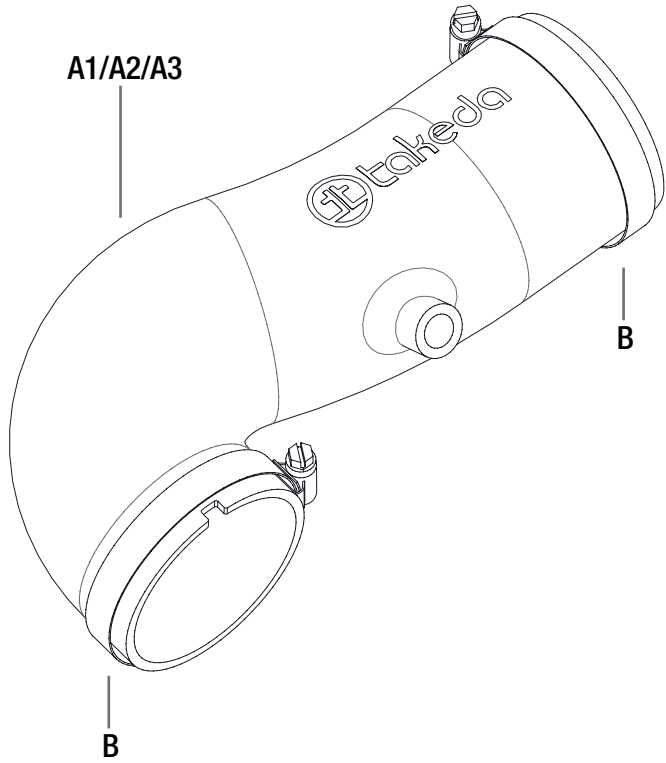
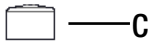



Refer to Figure A for step 1

Step 1: Loosen clamps ① off throttle body and cabin noise chamber, disconnect crank case vent hose ②, then remove OE tube out of the vehicle. Do not throw away OE crank case hose clamp.

INSTALL



Figure B

Refer to Figure B for steps 2-5

Step 2: Install Takeda tube in to vehicle using the bigger supplied clamps, and re-connect factory crank case vent line using the factory clamp.

Step3: Cap off the the cabin chamber with the supplied cap and clamp.

Step 4: Tighten all clamps down.

Step 5: Your installation is now complete. Thank you for choosing Takeda!

NOTE: Retighten all connections after approximately 100-200 miles.



C/F Intake System



P/N: TM-2013C-D (PDS)
TM-2013C-R (P5R)

Intake System



P/N: TM-2013B-D (PDS)
TM-2013B-R (P5R)

Twisted Steel Header



P/N: 48-36005-HC (Street)
48-36005-HN (Race)

Cat-Back Exhaust



P/N: 49-36023-P (Pol Tips)
49-36023-B (Blk Tips)

Sprint Booster V3



P/N: 77-16502

Oil Filter



P/N: 44-LF018

Takeda Tee



P/N: 40-30332 M
P/N: 40-30333 L
P/N: 40-30334 XL

Lic. Plate Frame



P/N: TP-7014F

OE Replacement Filter



P/N: 30-10094-1 (P5R)
31-10094-1 (PDS)

Throttle Body Spacer



P/N: 46-38009