

advanced FLOW engineering

Instruction Manual P/N: TM-1023B-D/ TM-1023B-R



Make: **Honda** Model: **S2000 (AP1/AP2)** Year: **2000-2009** Engine: **L4-2.0L/2.2L**



- Please read the entire instruction manual before proceeding.
- Ensure all components listed are present.
- If you are missing any of the components, call customer support.
- Ensure you have all necessary tools before proceeding.
- Do not attempt to work on your vehicle when the engine is hot.
- Disconnect the negative battery terminal before proceeding.
- Retain factory parts for future use.

Retain factory parts for future use.

| Label | Qty. | Description | Part Number |
|-------|------|--------------------------|-----------------------|
| A1 | 1 | Air Filter (Pro DRY S) | 21-91106 (Grey Media) |
| A2 | 1 | Air Filter (Pro 5R) | 24-91106 (Blue Media) |
| B | 1 | Tube | 05-T1023B1 |
| C | 1 | Housing | 05-T1023B2 |
| D | 1 | Coupling Elbow, Silicone | 05-01379 |
| E | 2 | Clamp #048 | 03-50007 |
| F | 1 | Grommet, Chassis | 03-50033 |
| G | 1 | Grommet, Air Temp | 03-50268 |
| H | 1 | Screw, Torx: M4 | 03-50491 |
| I | 1 | Clamp, Mini | 03-50025 |
| J | 1 | Retainer Clips | 05-01197 |
| K | 1 | Cap, Vinyl | 03-50035 |
| L | 2 | Ties, Nylon | 03-50492 |
| M | 1 | Seal, Trim: (22") | 05-00072 |

Installation will require the following tools:

flat head screw driver, 8mm nut driver, ratchet, extension, 10mm socket, pliers, 5/8" drill bit

Note: Legal in California for use on race vehicles only. The use of this device on vehicles used on public streets or highways is strictly prohibited in California and others states that have adopted California emission regulations.

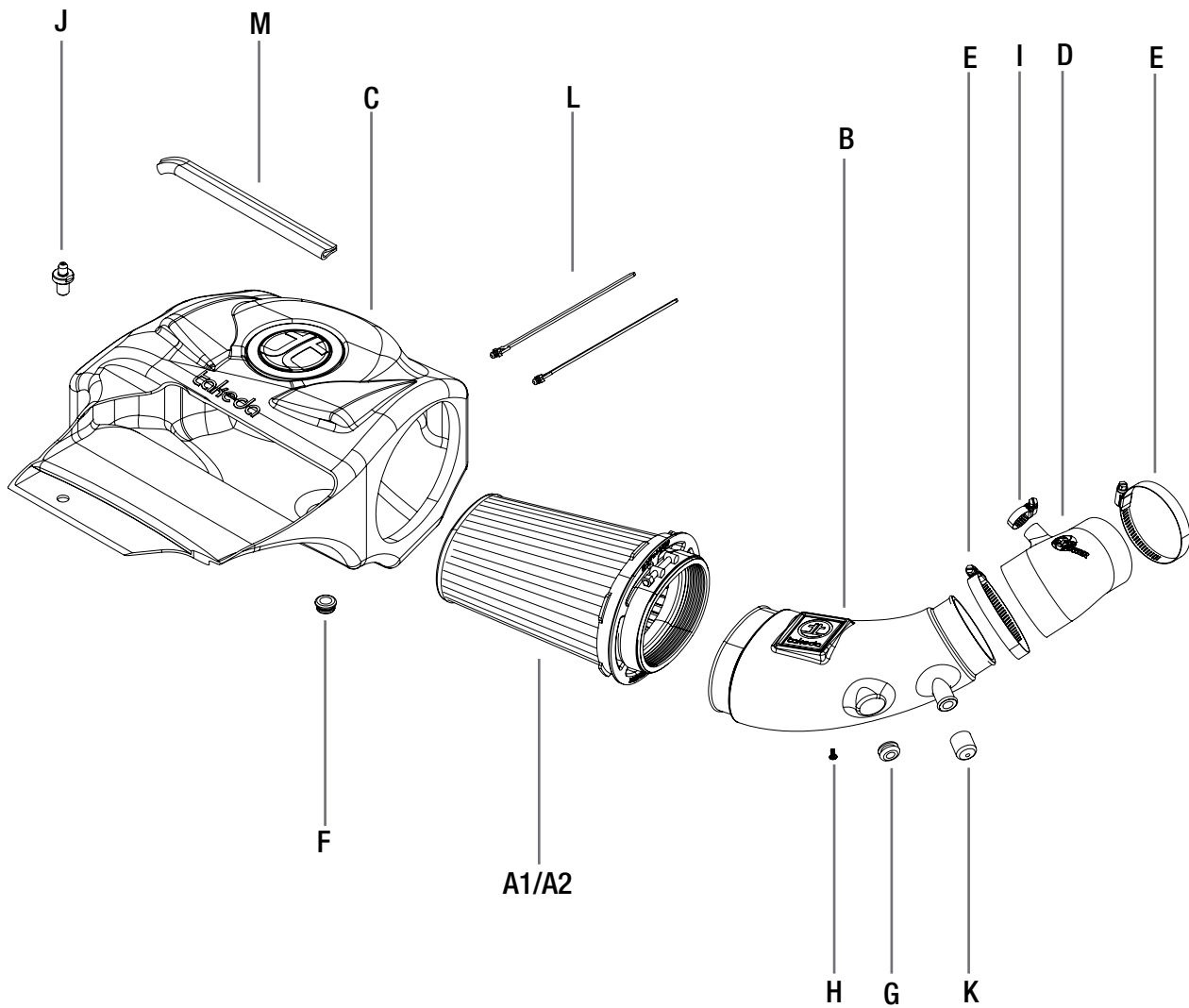

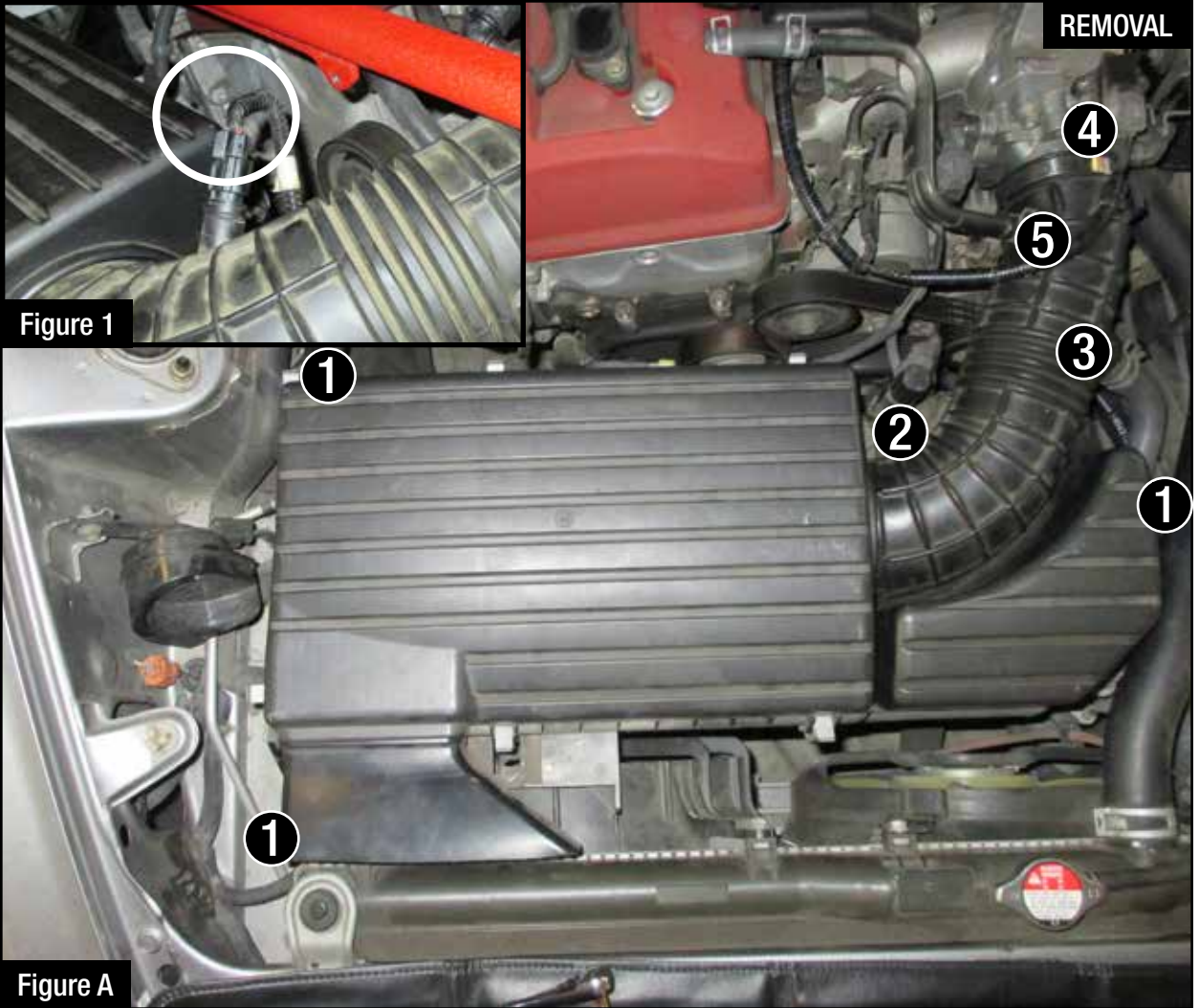

REMOVAL

Figure 1

Figure A

Refer to Figure A for Steps 1-5

Note: Make sure car is cool before starting this installation to avoid coolant burns.

- Step 1: Remove the top of the stock air box. To do so, unhitch the six clips on the stock air box.
- Step 2: Remove the three 10 mm bolts around the stock housing (1).
- Step 3: For vehicles with a vacuum pump, unscrew the vacuum pump from the stock housing, located beside the intake tube (2).
For vehicles with a temperature sensor, disconnect the sensor from the stock intake tube (Figure 1).
- For vehicles with vacuum hose, remove the hose from the stock intake tube (3).
- Step 4: Loosen the clamp at the throttle body (4), and remove the crankcase hose (5).
- Step 5: Carefully detach any hose lines attached to the airbox, then remove the intake from the vehicle.



Refer to Figure B for Steps 6-8

Step 6: Transfer two grommets from the stock air box to the Takeda housing (Figure 2).

Step 7: Install the supplied seal trim around the opening of the Takeda housing (6).

Step 8: Install cable ties on back of Takeda housing (7).

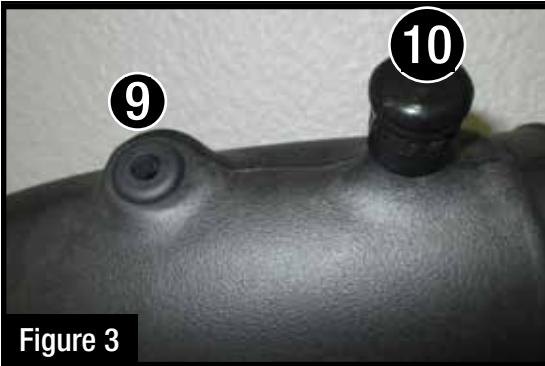

Figure 3

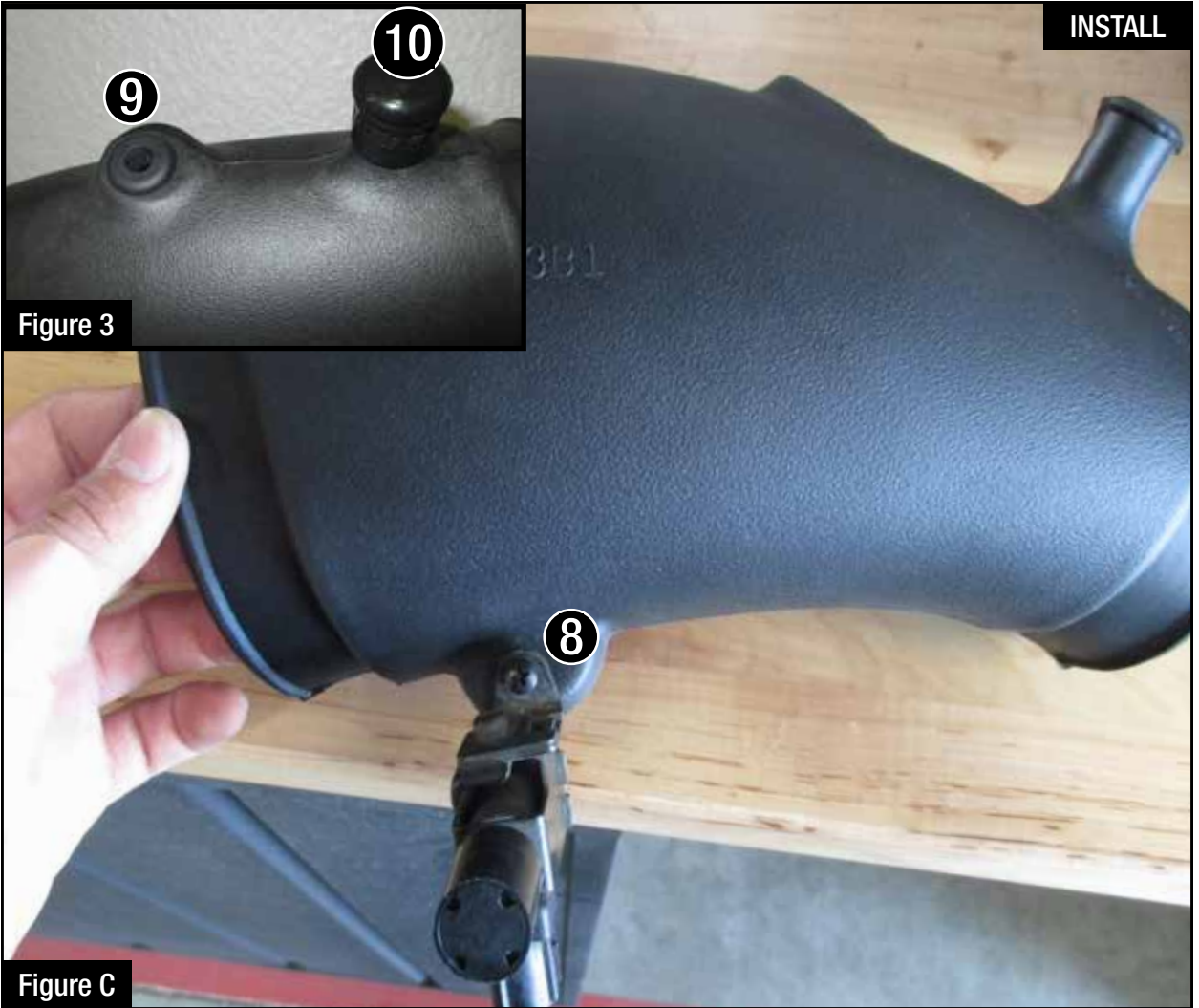

Figure C

Refer to Figure C for Steps 9-11

- Step 9: For vehicles with vacuum pumps, carefully remove the stock hose lines and disconnect sensor. If needed, take a photo to remember the placement of the lines. Install the vacuum pump on the Takeda intake tube with the supplied M4 screw and torx bit (8).
- Step 10: For vehicles with temp sensors, drill 5/8" hole into the tube, using the drill point as a guide. Then install the supplied grommet with the smaller hole into the Takeda intake tube (9) (Figure 3). Transfer the temp gauge from the stock intake tube to the Takeda intake tube.
- Step 11: For vehicles with no vacuum hose, install the supplied vinyl cap on the Takeda intake tube (10). (Figure 3)



Figure 4

Figure D

Refer to Figure D for Steps 12-14

Step 12: Insert the grommet with the larger hole into the slot on the chassis (Figure 4).

Step 13: Install the Takeda housing into the engine bay. Secure it using two stock screws from the factory air box, inside the housing.

Step 14: Insert air filter into housing and push in until it locks.

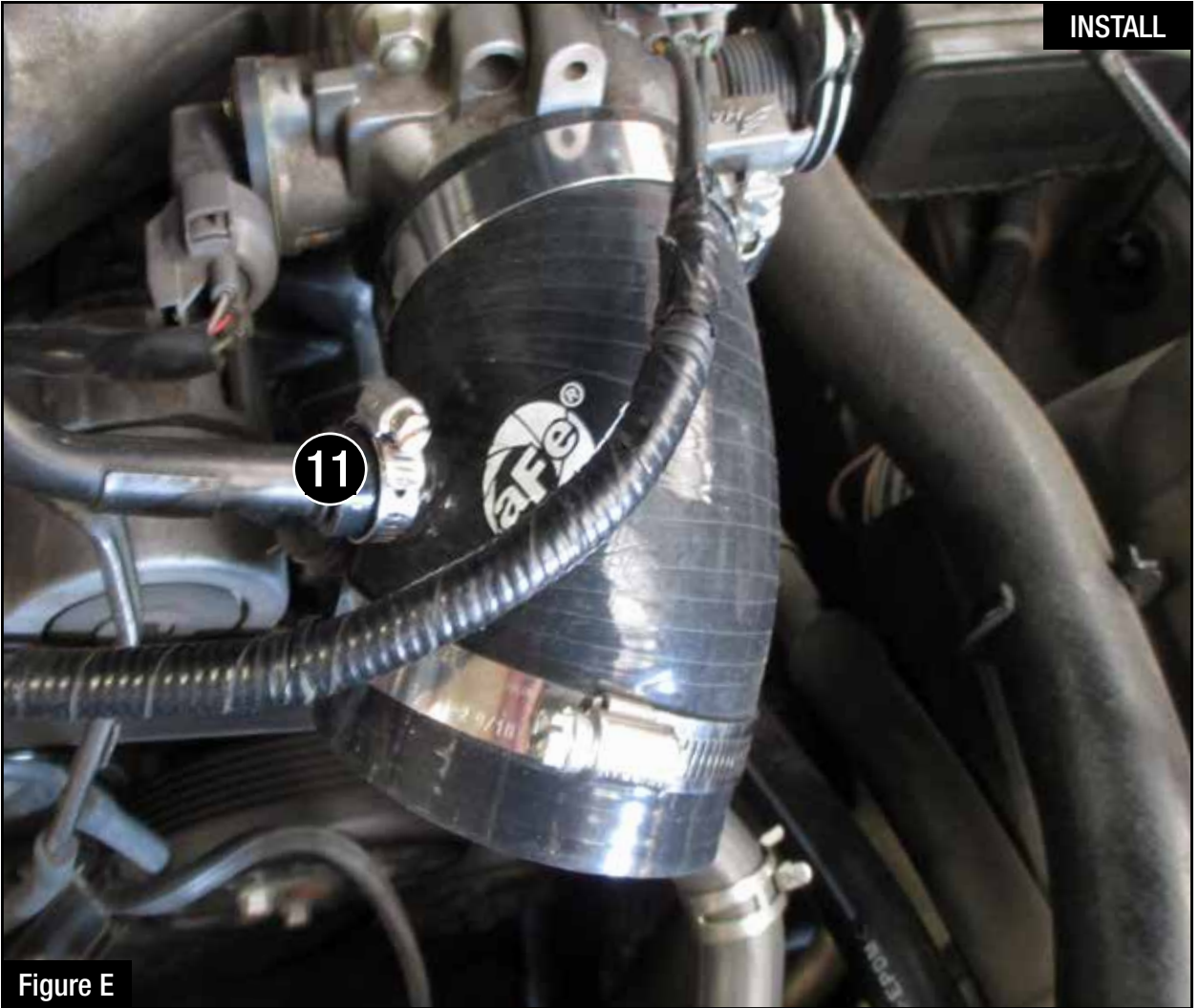
**Figure E****Refer to Figure E for Step 15**

Step 15: Install the aFe coupling over the throttle body. Place one aFe clamp over the throttle body and coupling. Do not tighten. Insert the stock crankcase hose into the coupling and clamp down with the supplied clamp ⑪.



Figure F

Refer to Figure F for Steps 16-19

Step 16: Install the Takeda intake tube into vehicle.

For vehicles with vacuum pumps, re-connect the stock air lines and sensor ⑫.

For vehicles with temp sensor, re-connect the temp sensor.

For vehicles with vacuum hose, re-connect the vacuum hose to the Takeda intake tube and tighten with the stock clamp ⑬.

Step 17: Secure housing with retention pin ⑭.

Step 18: Use the supplied zip ties to secure any hose lines behind the housing ⑮.

Step 19: Tighten all clamps and bolts securely. Re-connect battery. Check all the components are tight and secure. Your installation is now complete. Thank you for choosing aFe POWER!

NOTE: Check all bolts, clamps and connectors after 200 miles.



Pro DRY S Air Filter



P/N: 21-91106

Pro 5R Air Filter



P/N: 24-91106

Pro DRY S Restore Kit



P/N: TP-7015C

Blue Squeeze Restore Kit



P/N: 90-50501

aFe POWER Gloves



P/N: 40-10148 (M)
40-10149 (L)

Takeda T-Shirt



P/N: 40-30332 (M)
40-30333 (L)
40-30334 (XL)

aFe POWER LED Flashlight



P/N: 40-10131 (S)
40-10150 (L)

aFe German Lic. Plate



P/N: 40-10135

Warranty

General Terms:

- aFe warrants their products to be free from manufacturer's defects due to workmanship and material.
- This warranty applies only to the original purchaser of the product and is non-transferrable.
- Proof of purchase of the aFe product is required for all warranty claims.
- Warranty is valid provided aFe instructions for installation and/or cleaning were properly followed.
- Proper maintenance with regular inspections of product is required to insure warranty coverage.
- Damage due to improper installation, abuse, unauthorized repair or alteration is not warranted.
- Incidental or consequential damages or cost, including installation and removal of part, incurred due to failure of aFe product is not covered under this warranty.
- All warranty is limited to the repair and/or replacement of the aFe part. To request Return Goods Authorization ("RGA"). Upon receipt of the RGA, you must return the product to the address provided in the RGA, freight prepaid and accompanied with a dated proof of purchase and the RGA. Upon receipt of the defective product and upon verification of proof of purchase, aFe will either repair or replace the defective product within a reasonable time, not to exceed thirty days.

| Product Category | P/N Prefix | Warranty duration |
|----------------------------------|--------------------------------|--------------------------|
| Direct OE Replacement Filters | 10, 11, 30, 31, 71, 73 | Life of the vehicle |
| Racing Filters | 18 | 1 year |
| Universal | 21, 24, 72, TF | 2 years |
| Air Intake Systems | 50, 51, 54, 55, 75, TR, TA, TL | 2 years |
| Exhaust Systems | 49 | 2 years |
| Intercoolers & Intercooler Tubes | 46-2 | 2 years |
| Intake Manifolds | 46-1 | 2 years |
| Differential Cover | 46-7 | Life of the vehicle |
| Exhaust Manifolds | 46 | 2 years |
| Throttle Body Spacers | 46-3 | 2 years |
| Turbochargers | 46-6 | 2 years* |
| Fluid Filters | 44 | 90 days |
| Pre-Filters | 28 | 2 years |
| Heavy Duty OE Replacement | 70 | 2 years |
| PowerSports OE Replacement | 81, 87 | 2 years |
| PowerSports Intake Systems | 85 | 2 years |

No other warranty expressed or implied applies nor is any person or advanced FLOW engineering authorized to assume any other warranty. Some States do not allow the exclusion or limitation of incidental or consequential damages or do not allow limitations on how long an implied warranty lasts, so the above limitations or exclusions may not apply to you. This warranty gives you specific legal rights, and you may also have other rights which vary from State to State.

*See turbocharger warranty for more info