

advanced FLOW engineering
Instruction Manual P/N: 58-10002D / 58-10002R



Make: **Honda** Model: **Civic Type R** Year: **2017-2019** Engine: **I4-2.0L Turbo**



- Please read the entire instruction manual before proceeding.
- Ensure all components listed are present.
- Ensure you have all necessary tools before proceeding.
- Do not attempt to work on your vehicle when the engine is hot.
- Disconnect the negative battery terminal before proceeding.
- Retain factory parts for future use.

Retain factory parts for future use.

Label	Qty.	Description	Part Number
A1	1	Air Filter (Pro DRY S)	21-91103 (Grey Media)
A2	1	Air Filter (Pro 5R)	24-91103 (Blue Media)
B	1	Tube, Carbon Fiber	05-T1025C1
C	1	Housing, Carbon Fiber	05-T1025C2
D	1	Coupling, Silicone Hump	05-01455
E	2	Clamp, #044	03-50019
F	2	Screw, Torx: M4	03-50491
G	1	Torx Bit: T20	03-50066
H	1	Slit Loom (12" inches)	03-50586

Installation will require the following tools:

Flat head and Philips screw drivers, ratchet, 10mm socket, extension, 8mm nut driver.

Note: Legal in California for use on race vehicles only. The use of this device on vehicles used on public streets or highways is strictly prohibited in California and others states that have adopted California emission regulations.

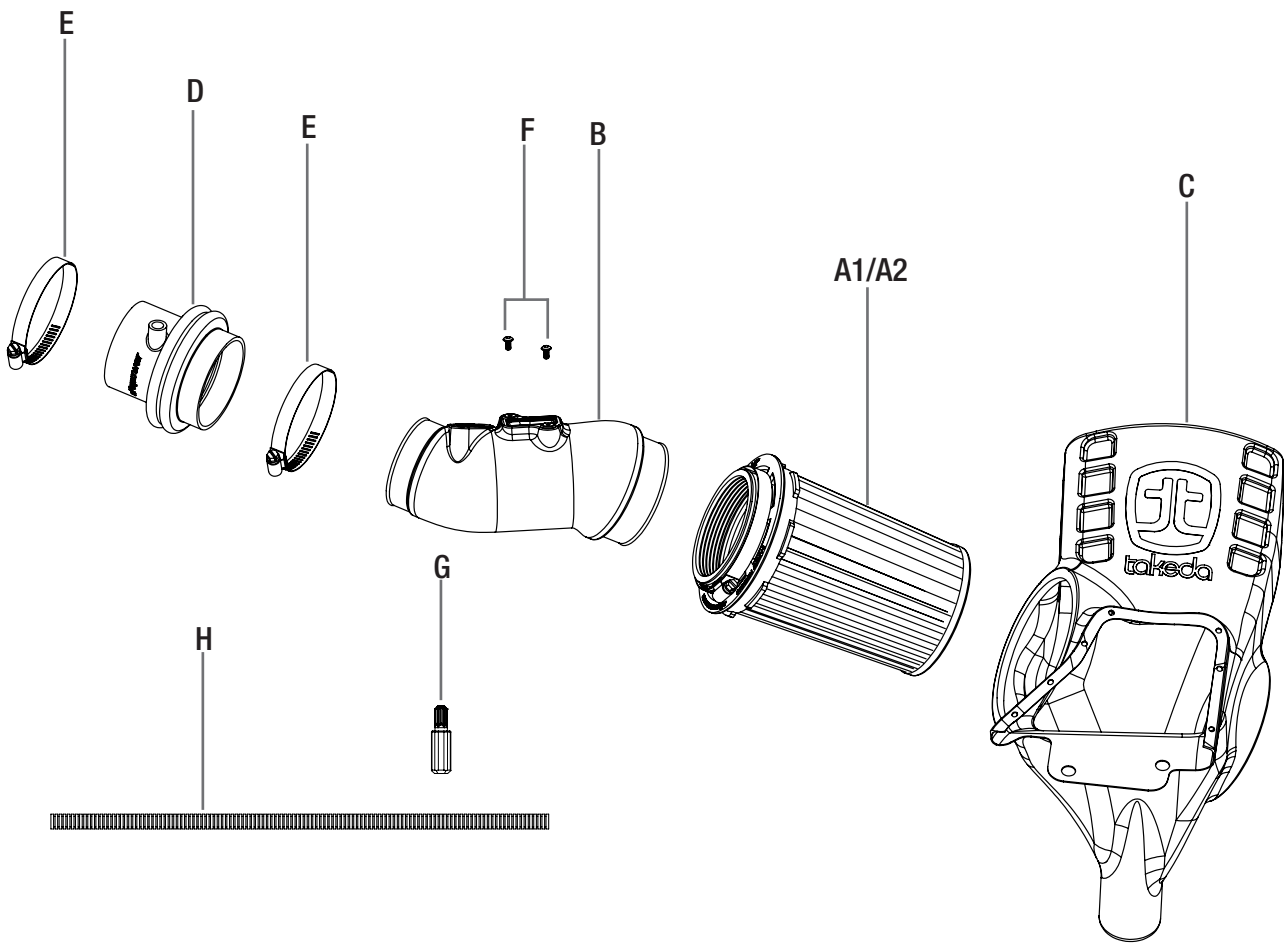

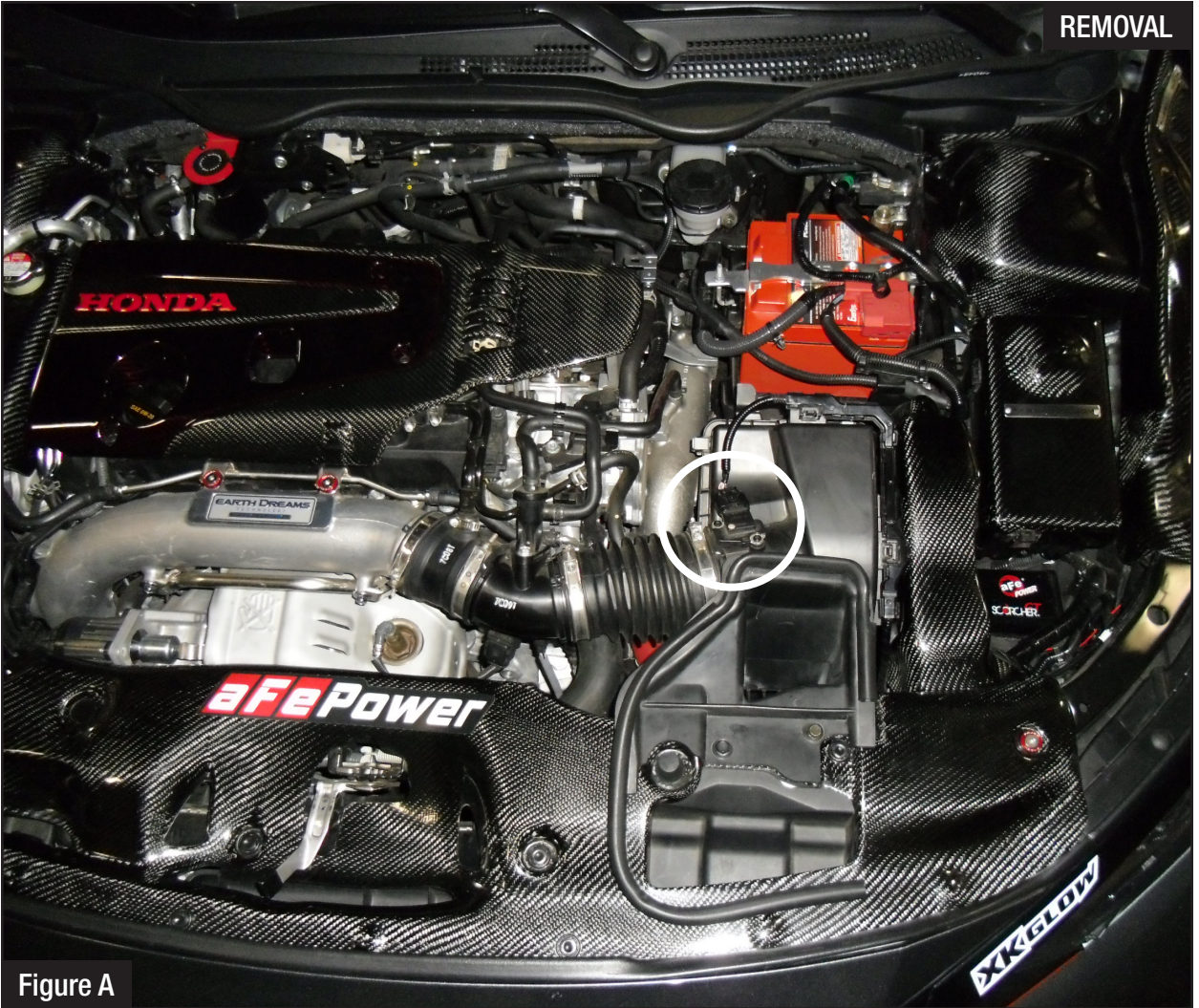

Figure A

Refer to Figure A for Step 1

Step 1: Disconnect the Mass Air Flow (MAF) harness.

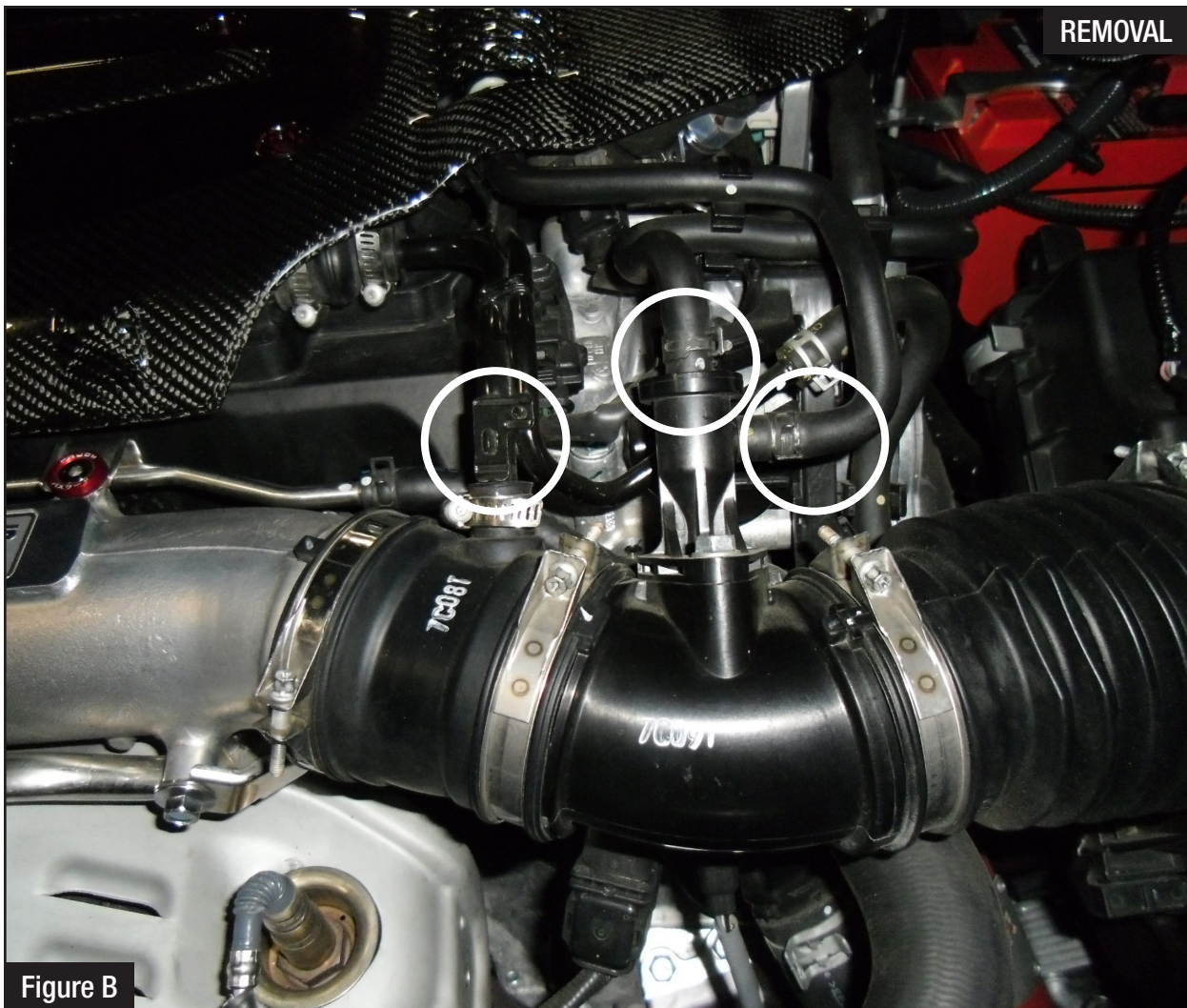

Figure B

Refer to Figure B for Steps 2-3

Step 2: Disconnect both hose on the Purge jet.

Step 3: With an upwards motion pull off the crank case line from the stock coupling.

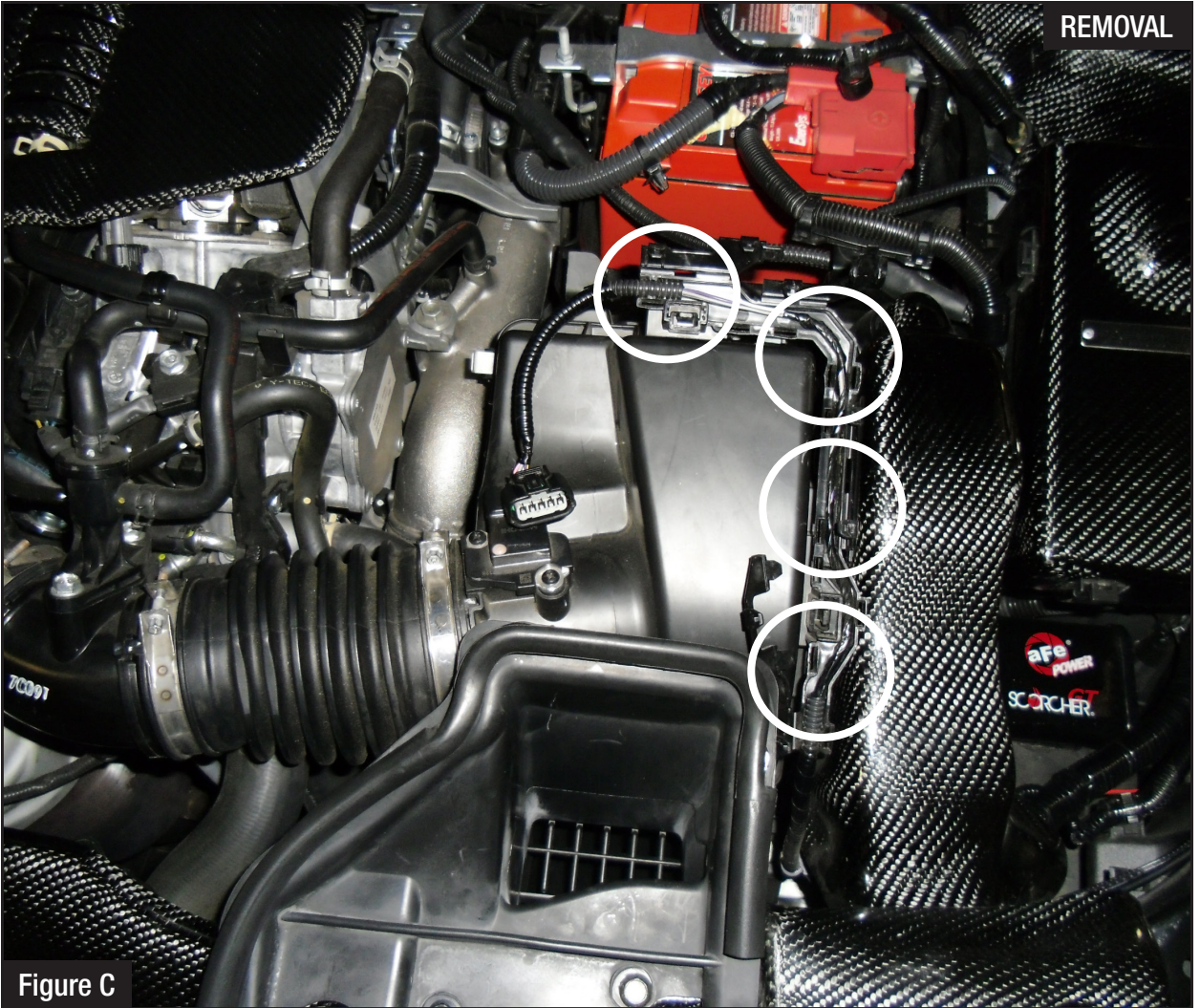

Figure C

Refer to Figure C for Step 4

Step 4: With A small flat head screwdriver unclip the harness holder and open to release the MAF harness free.

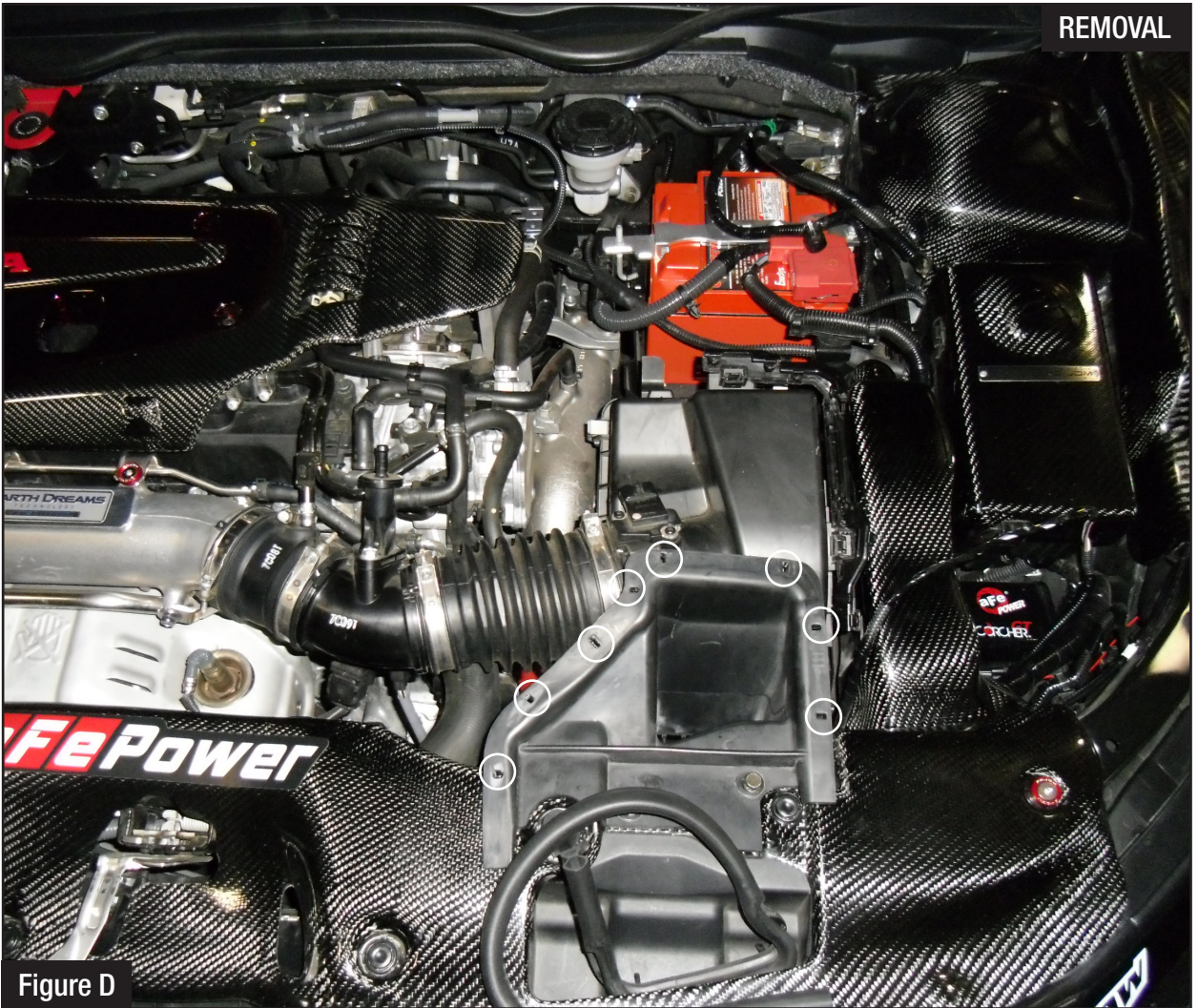

Figure D

Refer to Figure D for Step 5

Step 5: Carefully remove the seal trim and retaining clips off the factory airbox.



Figure E

Refer to Figure E for Steps 6-8

Step 6: Loosen the factory clamp on the silicone coupling.

Step 7: Remove the four 10mm bolts securing the factory housing. Do not discard the bolts at this time they will be reused.

Step 8: With an upward motion pull the factory intake system out of the vehicle.



Figure F

Refer to Figure F for Steps 9-10

Step 9: Transfer one of the mounting grommet on the factory airbox to the Takeda housing.

Step 10: Transfer the factory grommet from the bottom of the airbox to the Takeda housing.

**Figure G****Refer to Figure G for Steps 11-12**

Step 11: Using a Philips screw driver remove the MAF sensor from the factory intake tube and transfer to the Takeda intake tube using the supplied torx screws.

Step 12: With a 10mm socket and wrench remove the purge jet off the factory intake tube. Transfer it to the Takeda intake tube and secure it with the factory bolts.

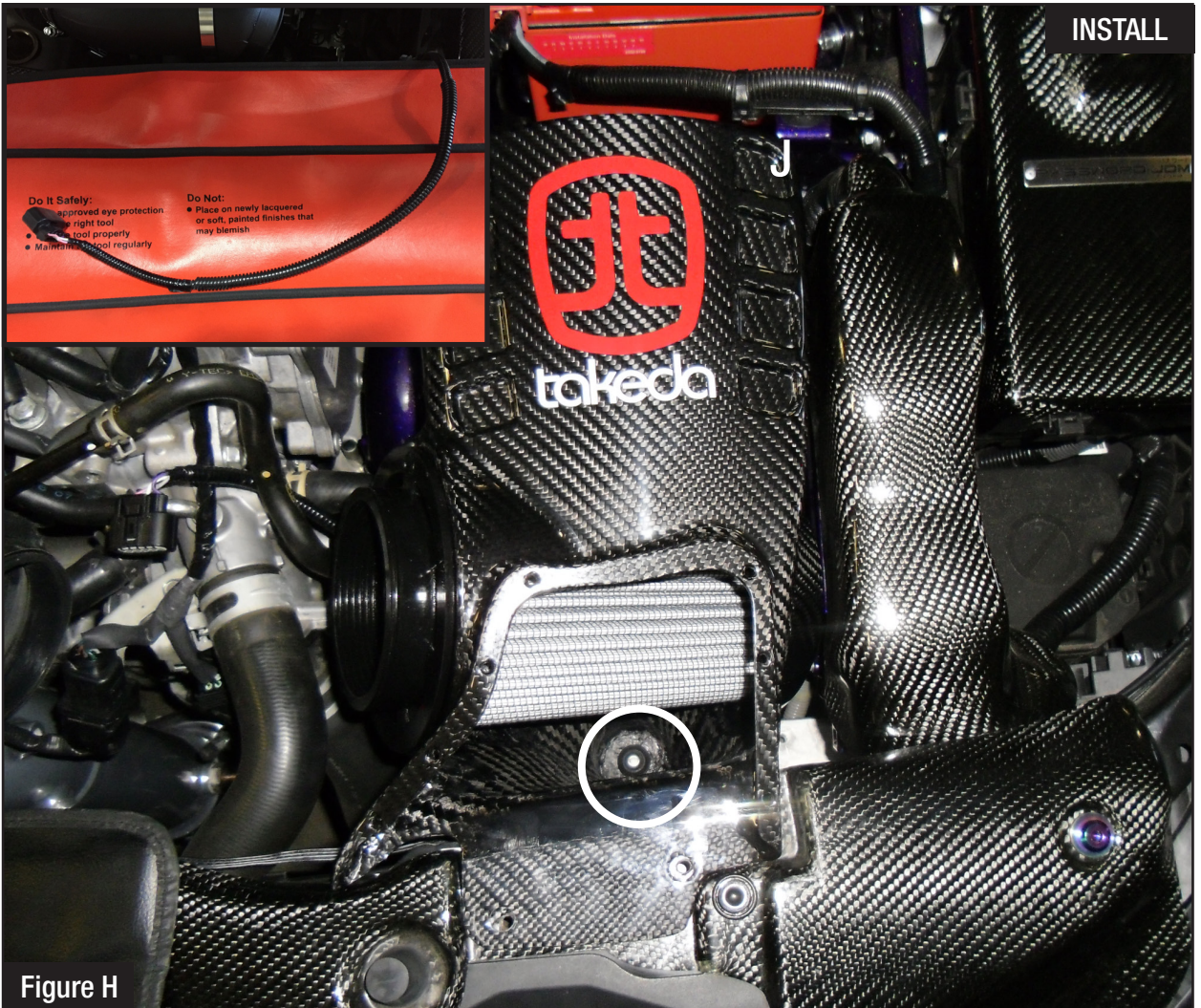

Refer to Figure H for Steps 13-14.

Step 13: Install the split loom over the exposed MAF wire harness.

Step 14: Install the Takeda housing into the engine bay, place the bottom grommet onto the factory peg.

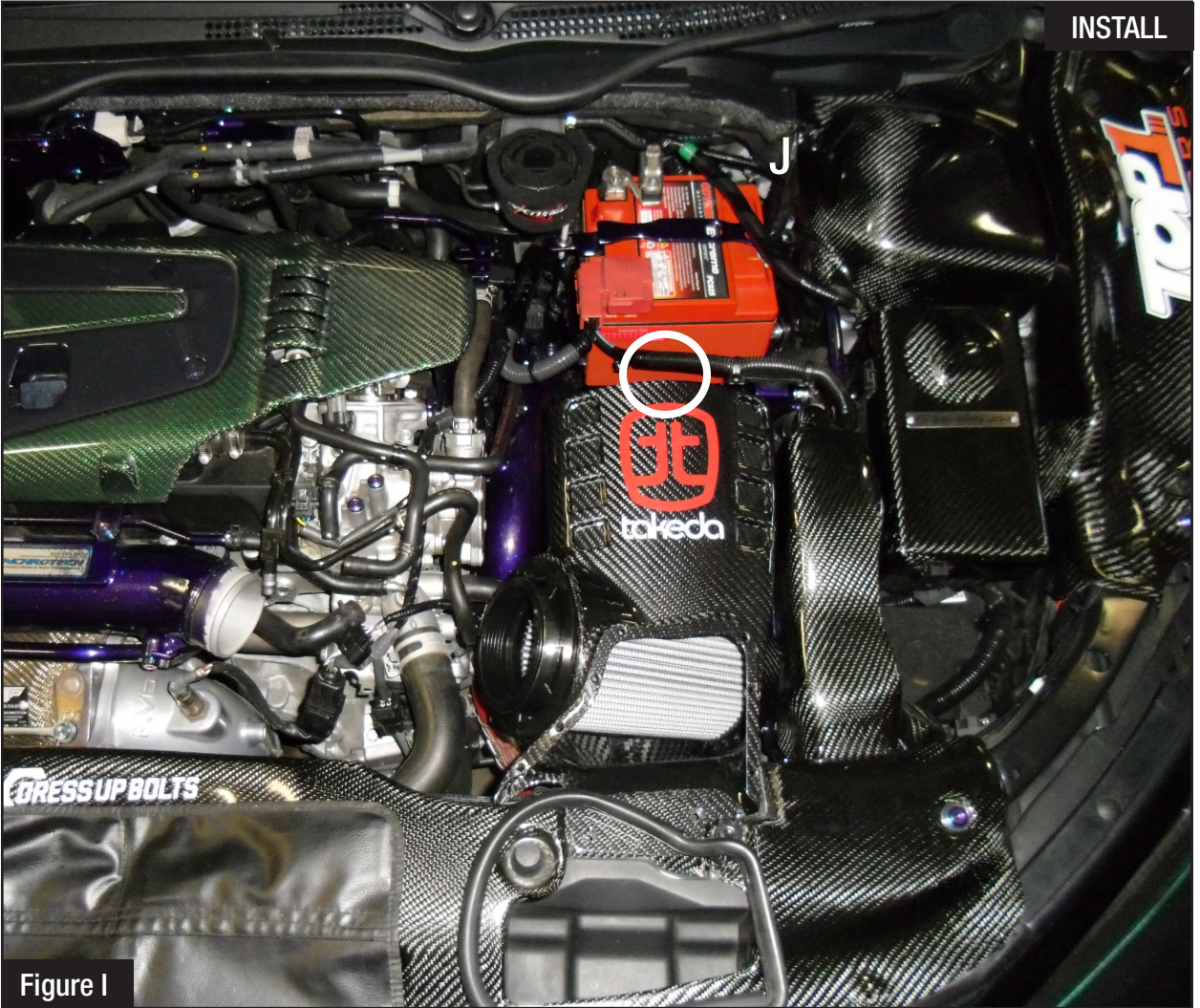

Figure I

Refer to Figure I for Steps 15-16

Step 15: Secure the housing to the rear mounting location using the bolt removed at Step 7.

Step 16: Insert the Takeda air filter into the Takeda housing, assure the locking tabs are lock on the housing.



Figure J

Refer to Figure J for Step 17

Step 17: Insert the factory crank case fitting into the supplied coupling and install with the clamps onto the turbo manifold inlet. Do not tighten clamps at this time.

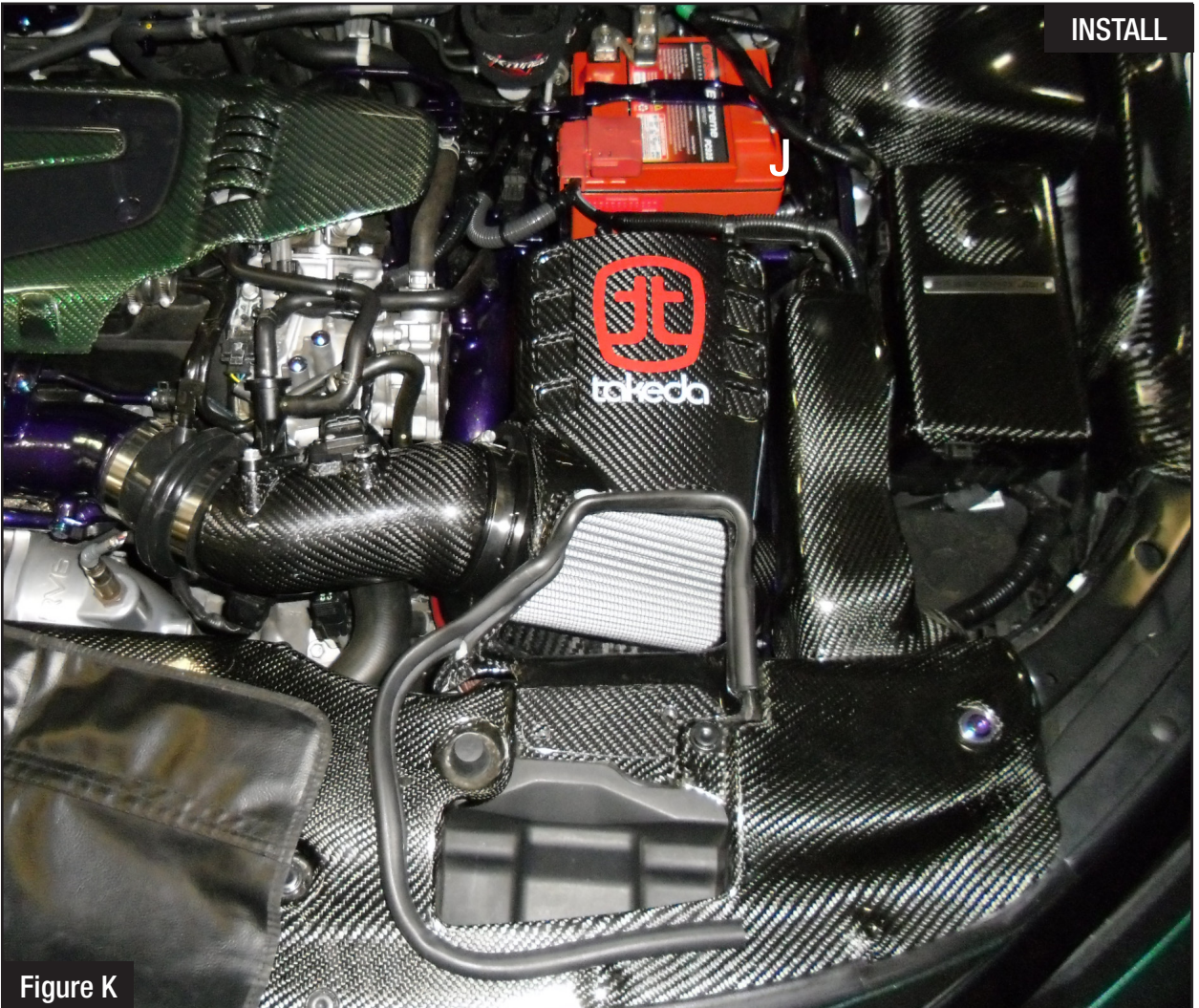

Figure K

Refer to Figure K for Steps 18-24

Step 18: Install the factory trim seal on the top edge of the Takeda housing.

Step 19: Slide the Takeda intake tube into the air filter then slide it into the coupling.

Step 20: Reconnect the two hoses on the purge jet accordingly.

Step 21: Reconnect MAF sensor harness.

Step 22: Align the intake tube with the air filter and coupling. Tighten all clamps.

Step 23: Secure the front of the housing with the two other bolts removed at Step 7.

Step 24: Make sure all clamps and connections are secured. Your installation is now completed.



Pro DRY S Air Filter



P/N: 21-91103

Pro 5R Air Filter



P/N: 24-91103

Pro DRY S Restore Kit



P/N: TP-7015C

Blue Squeeze Restore Kit



P/N: 90-50501

SCORCHER GT Module



P/N: 77-46601

Cat-Back Exhaust System

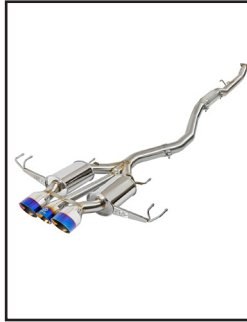

P/N: 49-36616-L (Blue Tips)
49-36616-P (Pol. Tips)
49-36616-C (C/F Tips)
49-36616-B (Blk. Tips)

Turbo Downpipe



P/N: 48-36606-HC (Street)
48-36606-HN (Race)

Rear Downpipe/Mid-Pipe



P/N: 49-36617

Intercooler Chargepipes



P/N: 46-20324-R

Test Pipe/Delete Pipe



P/N: 49-36622

aFe Control Lowering Springs

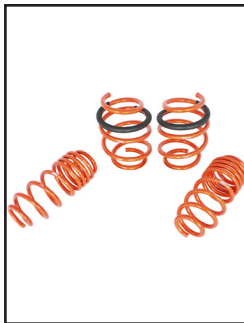

P/N: 410-701001-N

aFe Control Sway Bars

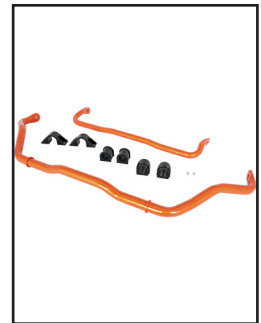

P/N: 440-701001-N