

advanced FLOW engineering Takeda Momentum Cold Air Intake System

Instruction Manual P/N: 56-70037D / 56-70037R

Make: Toyota

Model: Supra (A90)

Year: 2021

Engine: L4-2.0L (t) B48

Make: BMW

Model: Z4 30i (G29)

Year: 2019-2021

Engine: L4-2.0L (t) B48



- Please read the entire instruction manual before proceeding.
- Ensure all components listed are present.
- Ensure you have all necessary tools before proceeding.
- Do not attempt to work on your vehicle when the engine is hot.
- Retain factory parts for future use.

Label	Qty.	Description	Part Number
A1	1	Air Filter (Pro DRY S)	21-91113
A2	1	Air Filter (Pro 5R)	24-91113
B	1	Tube	05-5670037B1
C	1	Housing	05-5670037B2
D	1	Coupling, Silicone Bellow: 3"ID x 2-1/2"L	05-01598
E	2	Clamp, #048	03-50007
F	1	Fitting, Aluminum: 1/4-NPT	03-50644
G	2	Screw, M4	03-50490

Installation will require the following tools:

6mm, 8mm, and 11mm nut drivers or sockets, socket wrench, flat-head screwdriver, T20 torx bit, and panel popper.

Emissions Disclaimer: This product is not currently CARB exempt and is not available for purchase in California or for use on any vehicle registered with the California Department of Motor Vehicles.

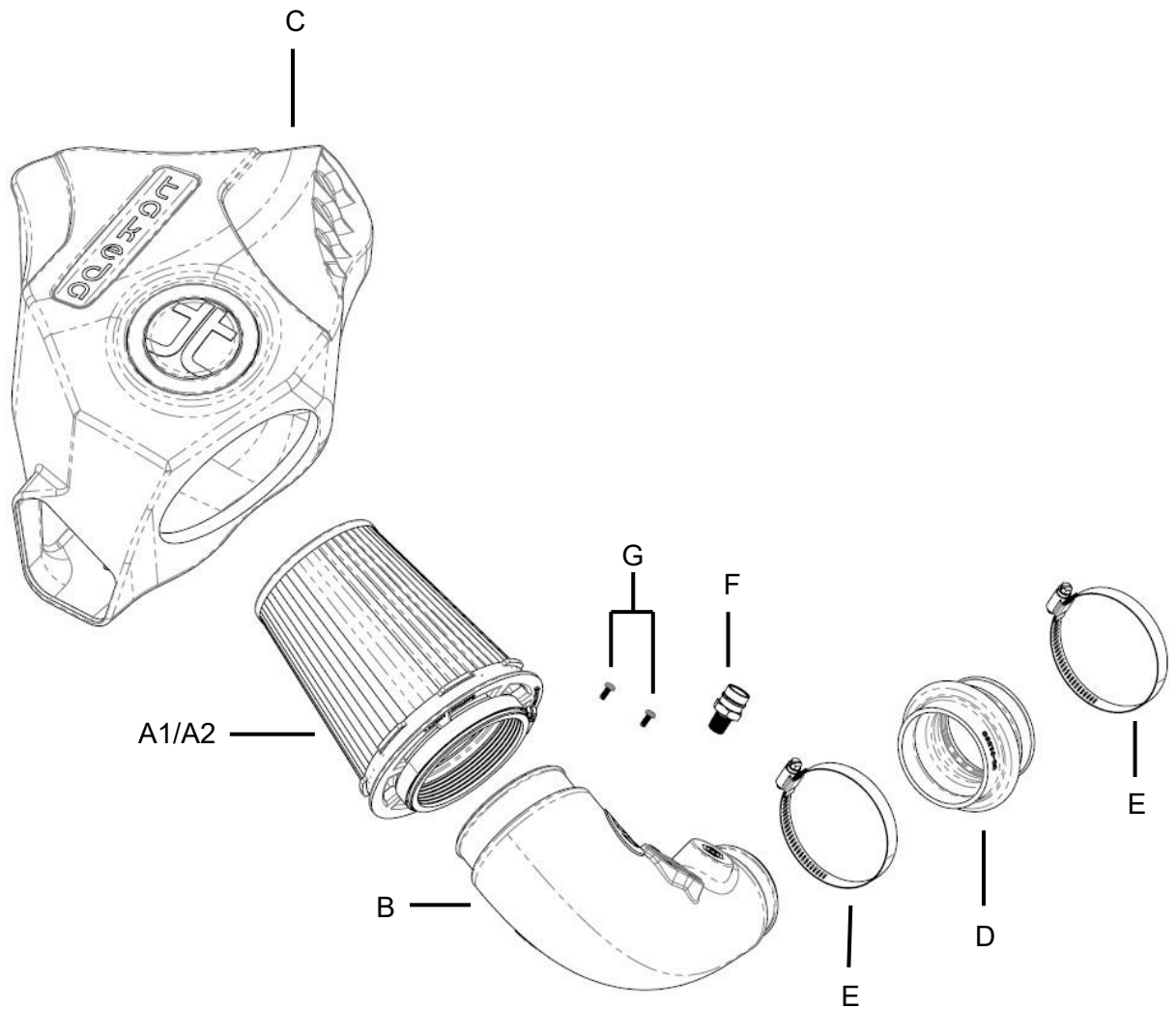



Refer to Figure A for Steps 1-4

Step 1: If the vehicle is equipped with a brace above the factory intake, remove the brace.

Step 2: Disconnect the temp sensor harness ①.

Step 3: Loosen the hose clamp at the factory airbox ②. Then, slide the factory intake tube away from the factory airbox.

Step 4: To remove the factory airbox, carefully pull up on the factory airbox.

**Figure B****Refer to Figure B for Steps 5-6**

Step 5: Next, detach the sensor harness from the factory intake tube (3).

Step 6: Disconnect the crankcase breather line (4).

**Figure C****Refer to Figure C for Step 7**

Step 7: Carefully remove the retention ring holding the factory intake tube to the turbo inlet (5). Then, carefully pull the factory intake tube out of the vehicle.

**Figure D****Refer to Figure D for Steps 8-9**

Step 8: Transfer the temp sensor from the factory airbox to the Takeda intake tube (6) and attach with the supplied screws.

Step 9: Install the supplied NPT fitting into the Takeda intake tube (7).

NOTE: This is an NPT fitting. The gap between the tube and hex is normal.

**Figure E****Refer to Figure E for Step 10**

Step 10: Install the supplied air filter into the Takeda housing (8) by firmly pushing it into the housing until the air filter tabs lock into place. Install the clamp over the air filter flange, but do not tighten at this time.

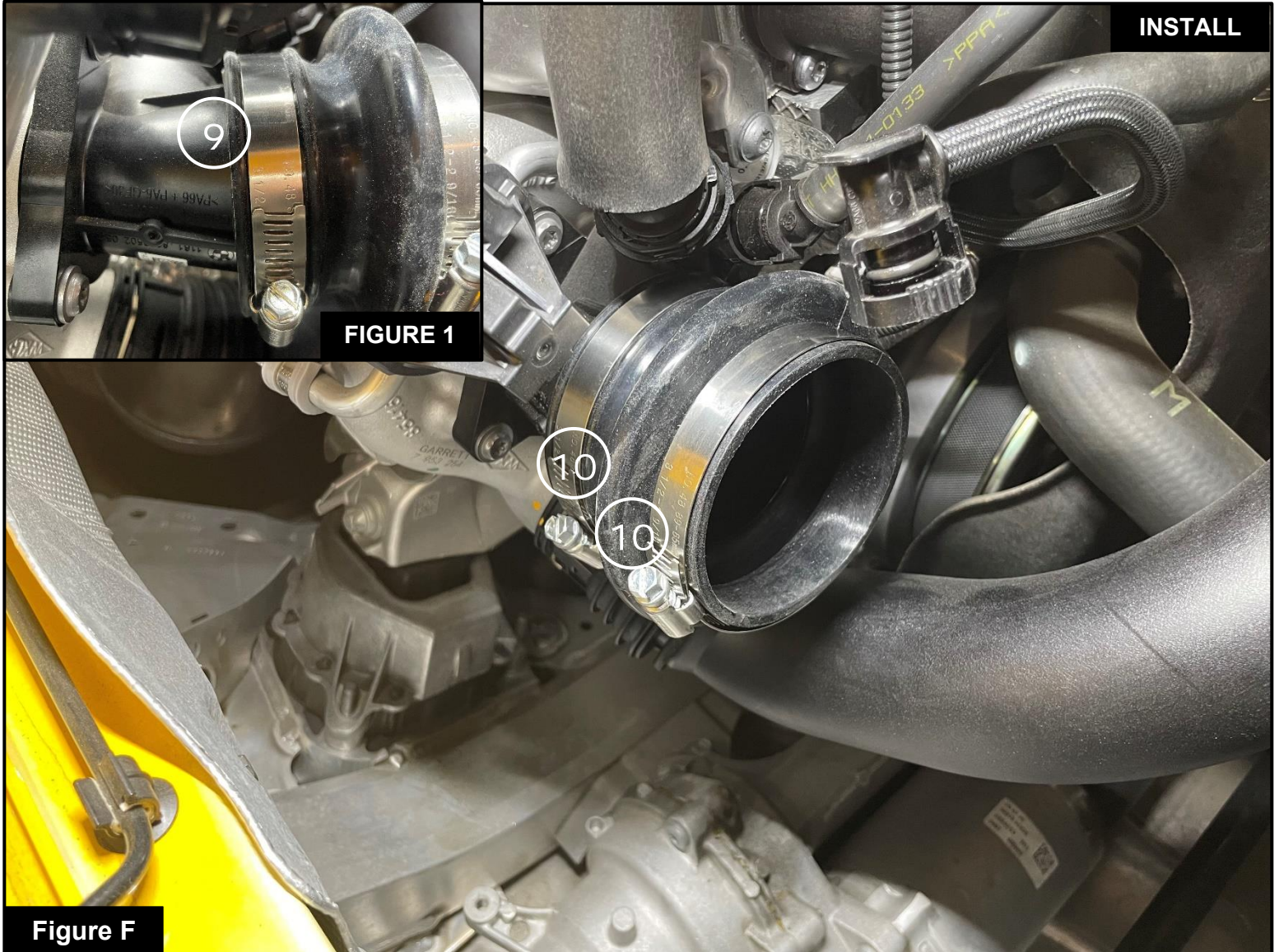

Refer to Figure F for Steps 11-12

Step 11: Install the supplied coupling onto the turbo inlet. Place the supplied clamps onto the coupling and orient the clamps as shown in Figure F (9). Make sure to have the end of the coupling sit flush to the rim of the turbo inlet. This is to make sure the interior lip of the coupling sits correctly in the groove of the turbo inlet. See Figure 1 (10) .

Step 12: When the coupling sits comfortably on the turbo inlet, tighten the clamp between the coupling and the turbo inlet. Do not tighten the clamp at the open end of the coupling.

**Figure G****Refer to Figure G for Steps 13-15**

Step 13: Install the Takeda intake tube into the coupling. Do not tighten the clamp at this time.

Step 14: Connect the crankcase breather line to the Takeda intake tube (11).

Step 15: Connect the temp sensor to the sensor harness (12).



Figure H

Refer to Figure H for Steps 16-20

Step 16: Install the assembled Takeda housing and air filter into the engine bay by pressing down firmly into the three (3) factory mounting grommets.

Step 17: Slip the Takeda tube into the air filter and tighten the clamp between the Takeda tube and air filter.

Step 18: Tighten the clamp between the Takeda intake tube and the coupling.

Step 19: If the vehicle is equipped with a brace, re-install the brace from **Step 1**.

Step 20: Make sure all components and connections are secure. Your installation is now complete. Thank you for choosing Takeda!