

advanced FLOW engineering Takeda Rapid Induction Cold Air Intake System

Instruction Manual P/N: 56-20040D / 56-20040R

Make: Mazda

Model: Miata MX-5

Year: 2016-2021

Engine: L4-2.0L



- Please read the entire instruction manual before proceeding.
- Ensure all components listed are present.
- If you are missing any of the components, call customer support.
- Ensure you have all necessary tools before proceeding.
- Do not attempt to work on your vehicle when the engine is hot.
- Retain factory parts for future use.

Label	Qty.	Description	Part Number
A1	1	Air Filter (Pro 5R)	24-91145
A2	1	Air Filter (Pro DRY S)	21-91145
B	1	Tube	05-5670006B1
C	1	Housing	05-5210004B2
D	1	Coupling, Silicone Bellow: (2.75" x 2.5")ID	05-01497
E	2	Clamp, 044 (2-5/16" - 3-1/4")	03-50019
F	1	Hose, Silicone: 3/8" ID (13" Length)	05-01502
G	1	Fitting, Elbow	03-50165
H	2	Screw, Torx M4	03-50490
I	1	Cap, Vinyl	03-50548
J	1	Seal Trim (21" Length)	05-00072

Installation will require the following tools:

T-20 Torx driver, #2 Phillips screwdriver, Flat-Head screwdriver, 8mm nut driver, 10mm nut driver, and needle-nose pliers.

Emissions Disclaimer: This product is not currently CARB exempt and is not available for purchase in California or for use on any vehicle registered with the California Department of Motor Vehicles.

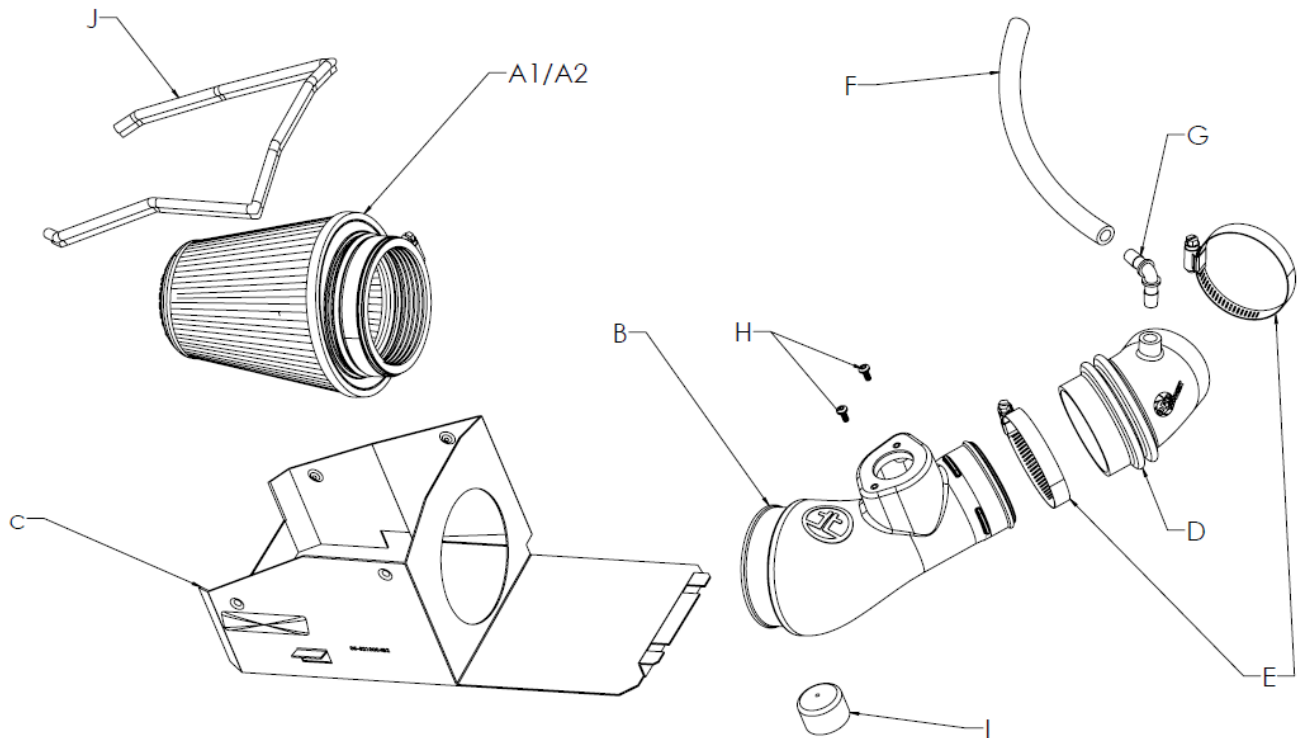

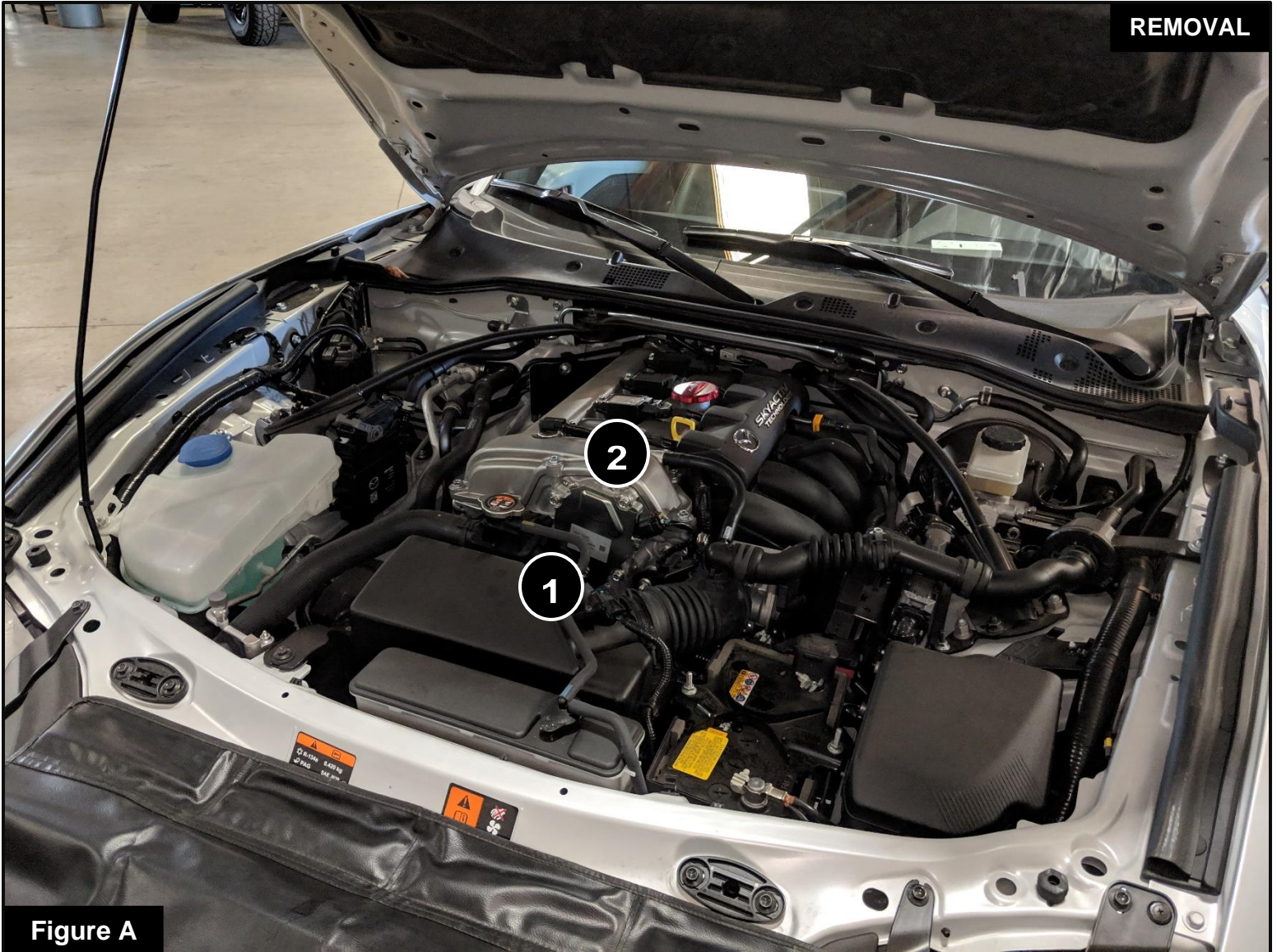
**Figure A****Refer to Figure A for Steps 1-4:**

Step 1: Disconnect the Mass Air Flow (MAF) harness from the sensor. ①

Step 2: Remove the MAF harness clip from the airbox using needle-nose pliers.

Step 3: Unclip the coolant reservoir line from the factory housing using a small flathead screwdriver.

Step 4: Disconnect the PCV hose from the valve cover fitting. ②

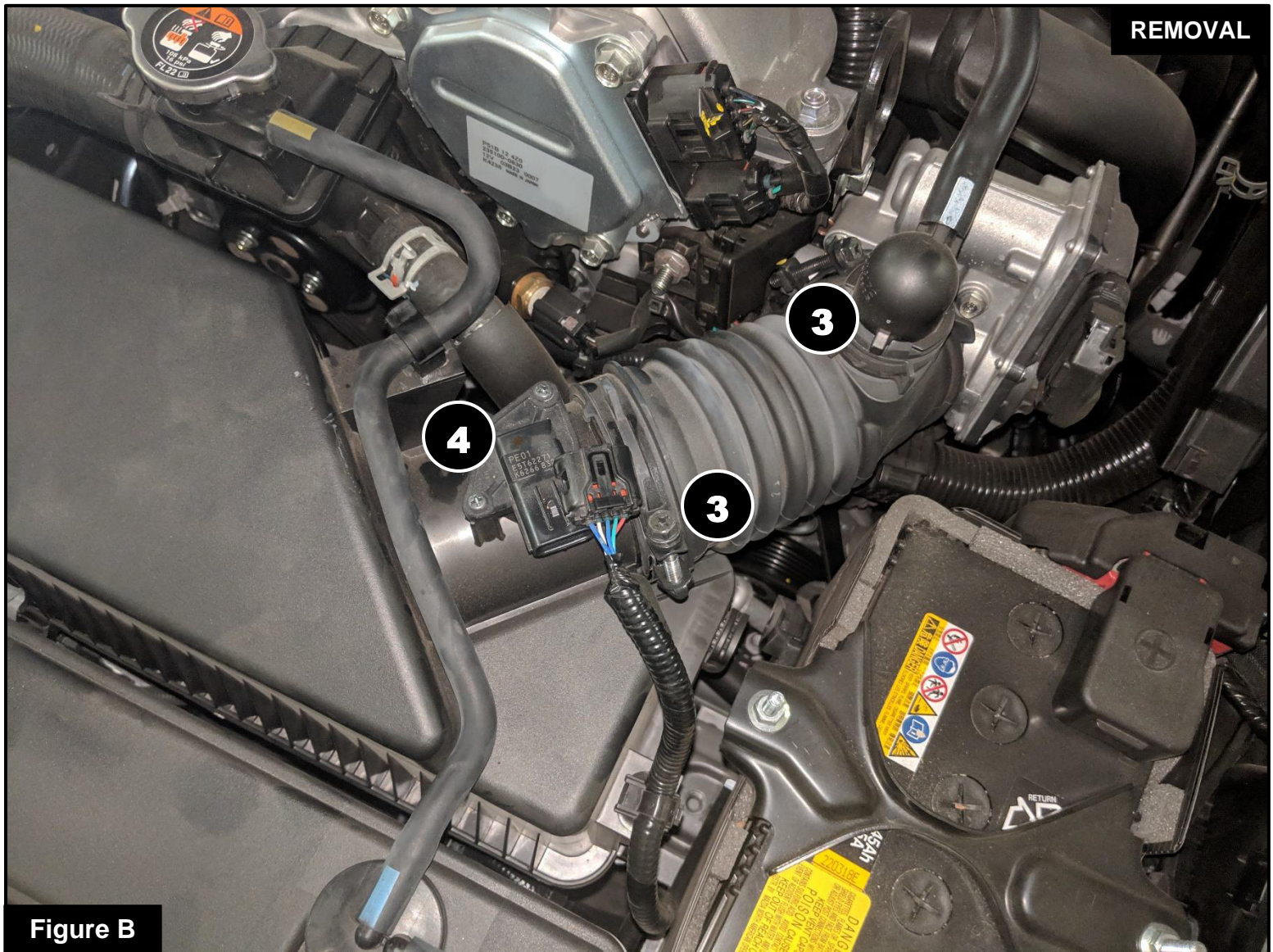

Figure B

Refer to Figure B for Steps 5-7:

Step 5: Using a 10mm nut driver, loosen the two clamps securing the tube to the factory intake box and the throttle body. (3)

Step 6: Remove the MAF Sensor from the factory housing using a #2 Phillips screwdriver. Save the sensor for reinstallation. (4)

Step 7: Remove the top part of the housing by releasing the two clips holding it down.

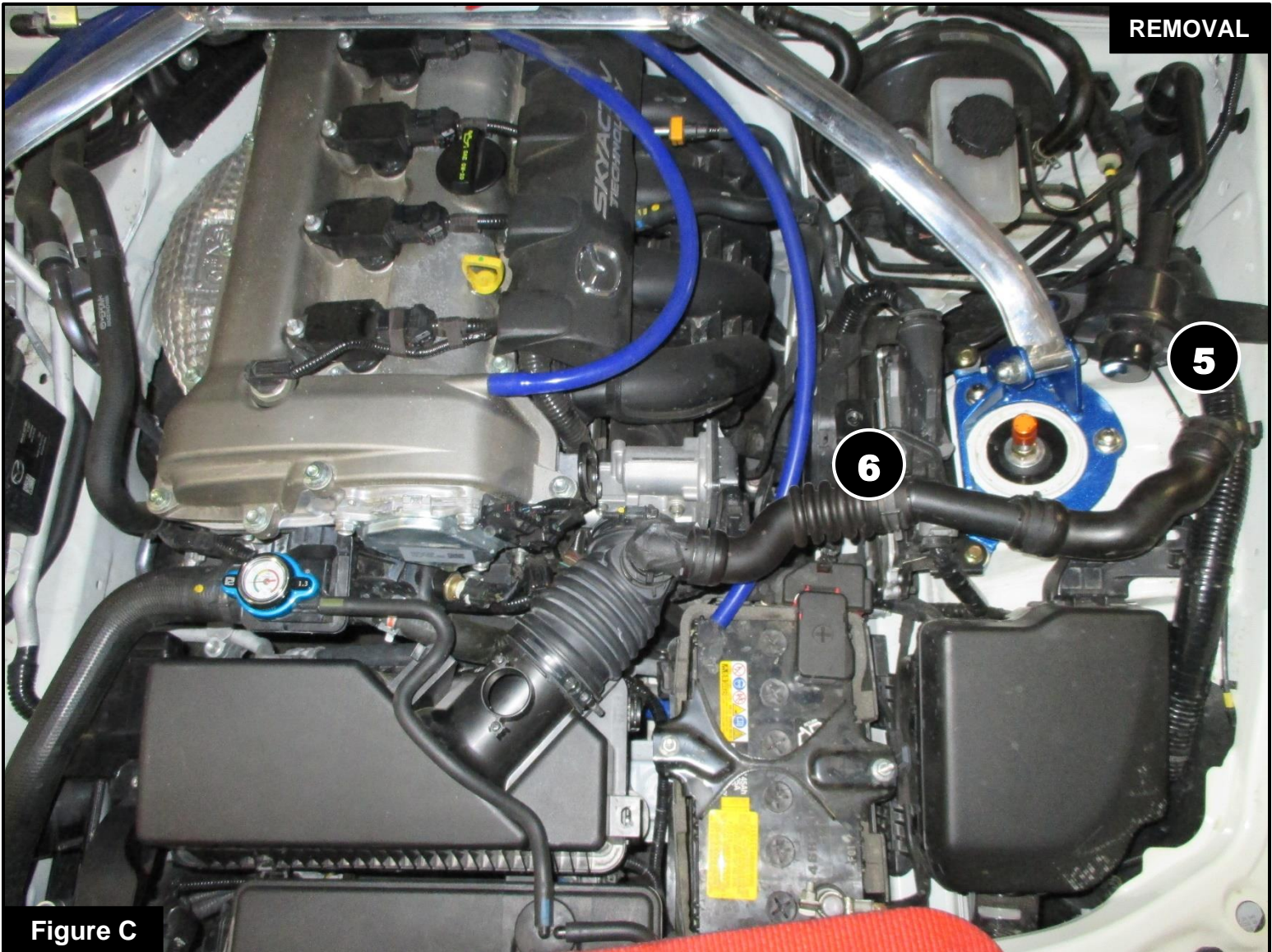

Refer to Figure C for Steps 8-10:

Step 8: Unclip the Sound tube assembly from the fitting leading to the firewall. ⑤

Step 9: Unscrew the Sound Tube bracket from the mount with a 10mm nut driver. ⑥

Step 10: Remove the factory intake coupling and sound tube assembly.



Figure D

Refer to Figure D for Step 11:

Step 11: Cover the sound tube fitting opening with provided vinyl cap.

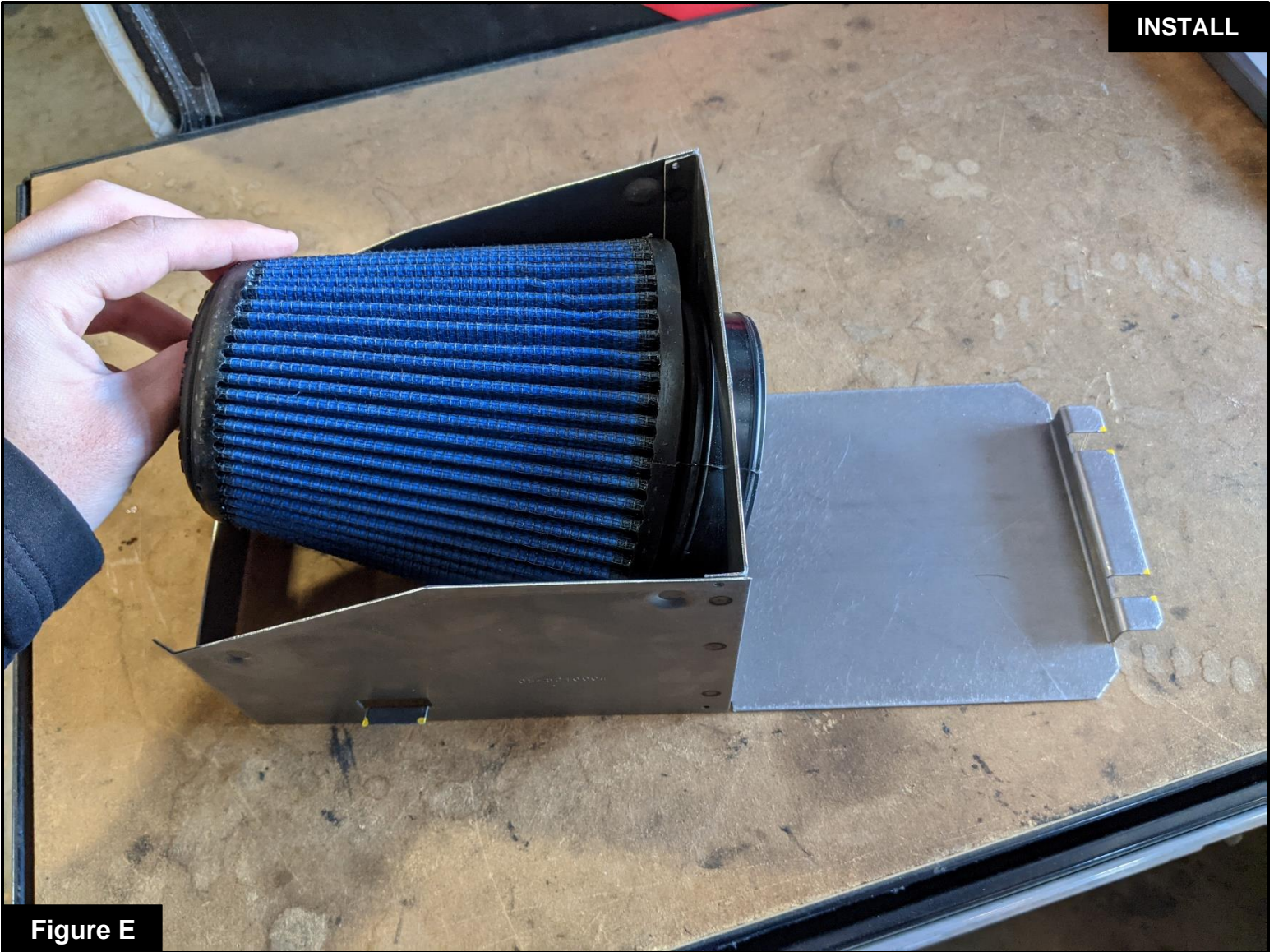
**Figure E****Refer to Figure E for Step 12:**

Step 12: Remove the filter clamp from the aFe POWER air filter. Slide the air filter into the aFe POWER housing from the top opening. Then guide the filter flange through the round opening in the housing and snap in the filter. Place the filter clamp on the filter flange but do not tighten at this time.

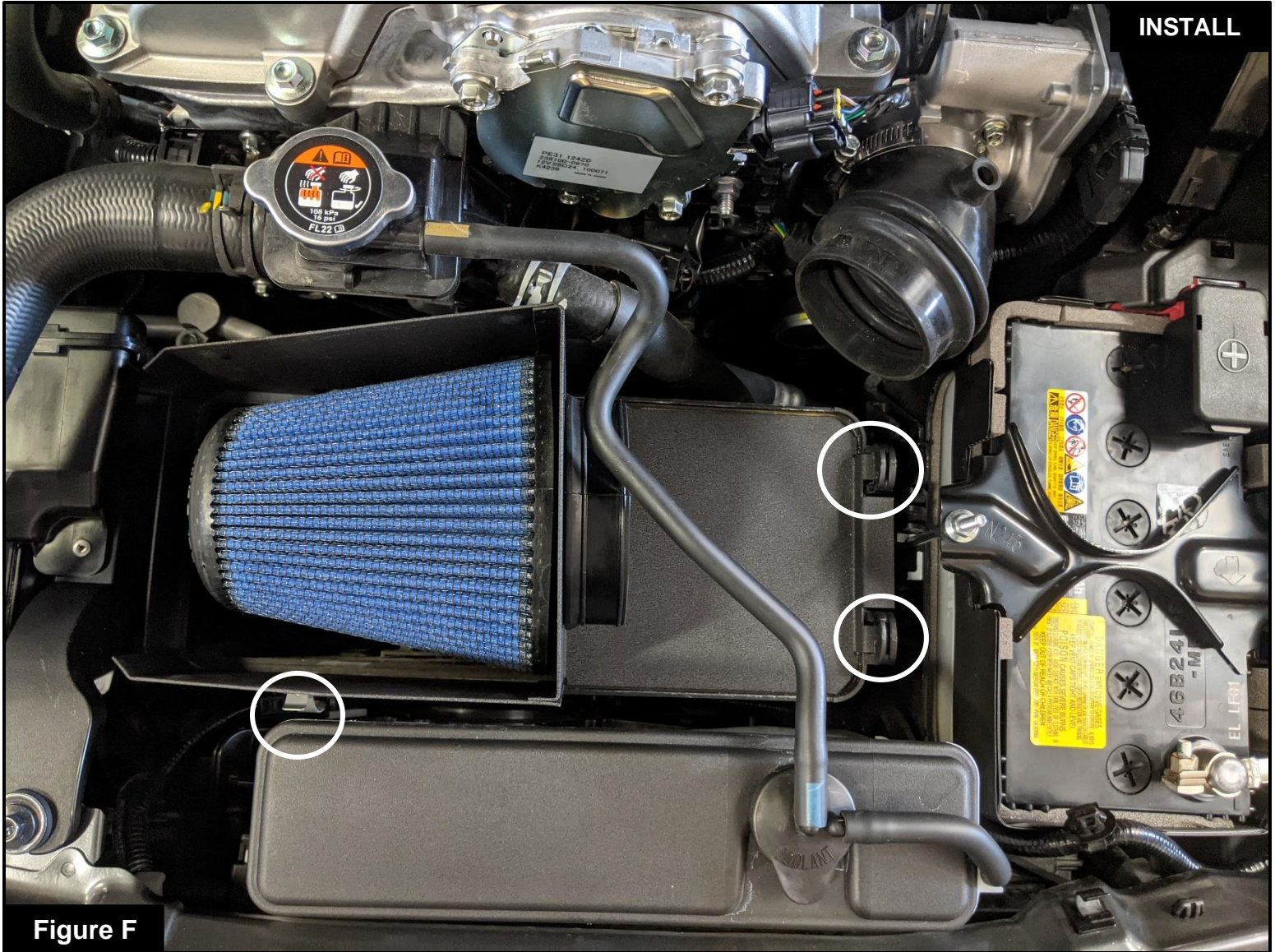

Refer to Figure F for Steps 13-14

Step 13: Slide the housing onto the top of the factory housing, and lock it into place with the factory locking tabs.

Step 14: Mount the coupling onto the throttle body with one of the provided worm clamps. Slide the second worm clamp onto the other end of the coupling. Do not tighten at this time.

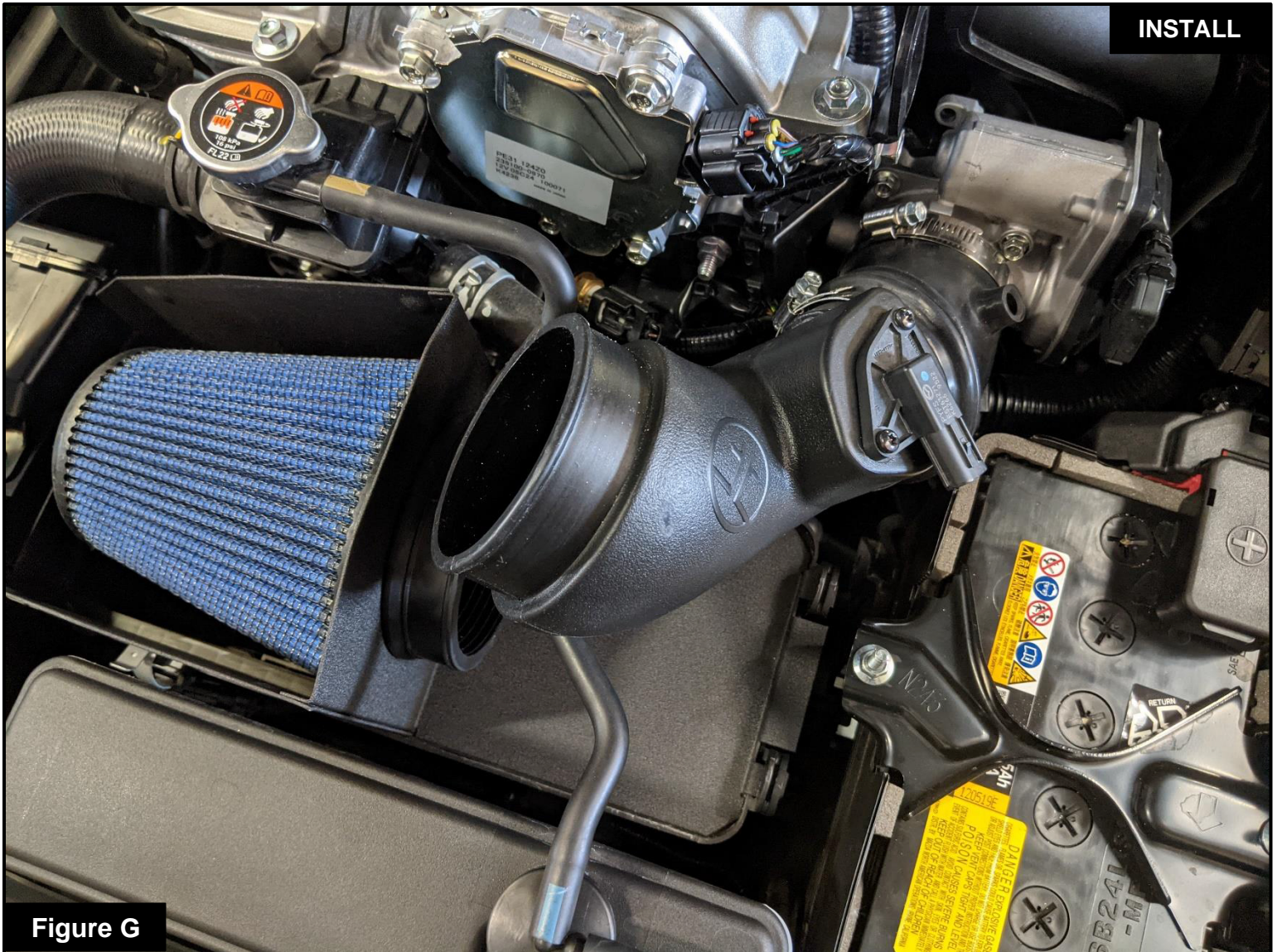

Figure G

Refer to Figure G for Steps 15-17

Step 15: Install the MAF sensor from the factory housing into the Takeda tube with the provided M4 screws.

Step 16: Install the tube into the coupling as shown.

Step 17: Rotate the tube down into the the air filter flange. Once the tube is aligned properly, tighten down the clamps at the air filter and on both ends of the coupling.



Figure H

Refer to Figure H for Steps 18-21

Step 18: Install the 90 degree fitting into the port on the coupling. Ensure it sits flush with the top of the port.

Step 19: Attach the supplied breather hose to the fitting on the coupling. Connect the other end to the vent port on the valve cover.

Step 20: Install the supplied seal trim along the top edge of the housing, cutting slots if necessary to help with bend angles.

Step 21: Reconnect the MAF sensor harness to the sensor.

Your installation is now complete. Thank you for choosing Takeda!



Pro DRY S Air Filter



P/N: 21-91145

Pro 5R Air Filter



P/N: 24-91145

Pro DRY S Restore Kit



P/N: 90-59999

Pro 5R Restore Kit



P/N: 90-50501

Pro DRY S Power Cleaner



P/N: 90-10101

Pro 5R Power Cleaner



P/N: 90-10201

Pre-Filter



P/N: 28-10083

Takeda Man Decal



P/N: TP-7003D

Sprint Booster V3



P/N: 77-16901

Throttle Body Spacer



P/N: 46-30001