

advanced FLOW engineering

Instruction Manual P/N: 51-76314 / 54-76314

Make: BMW	Model: 114i (F20/F21)	Year: 2012-2015	Engine: L4-1.6L (t) N13
Make: BMW	Model: 116i (F20/F21)	Year: 2011-2015	Engine: L4-1.6L (t) N13
Make: BMW	Model: 120i (F20/F21)	Year: 2015-2016	Engine: L4-1.6L (t) N13
Make: BMW	Model: 316i (F30/F31/F36)	Year: 2012-2015	Engine: L4-1.6L (t) N13
Make: BMW	Model: 320ed (F30)	Year: 2012-2015	Engine: L4-1.6L (t) N13



- Please read the entire instruction manual before proceeding.
- Ensure all components listed are present.
- If you are missing any of the components, call technical support.
- Ensure you have all necessary tools before proceeding.
- Do not attempt to work on your vehicle when the engine is hot.
- Disconnect both the negative battery terminal before proceeding.

Retain factory parts for future use.

Label	Qty.	Description	Part Number
A1	1	Air Filter (Pro 5R)	24-91056
A2	1	Air Filter (Pro DRY S)	21-91056
B	1	Housing	05-82212B2
C	1	Tube	05-76314B1
D	1	Torx Bit: T20	03-50066
E	2	Screw, Torx: M4	03-50489
F	1	Clamp, #044	03-50019
G	1	Clamp, #032	03-50016
H	1	Clamp, #096	03-50003
I	1	Coupling, Silicone	05-01433

Installation will require the following tools:

Phillips screwdriver & 8mm nut driver, flat head screwdriver, 11mm socket, socket wrench, T20 torx driver.

Note: Not legal for use in California. The use of this device in any on-road or off-road vehicles registered with the California Dept of Motor Vehicles (DMV) is strictly prohibited. (Vehicle does NOT exist in the US.)

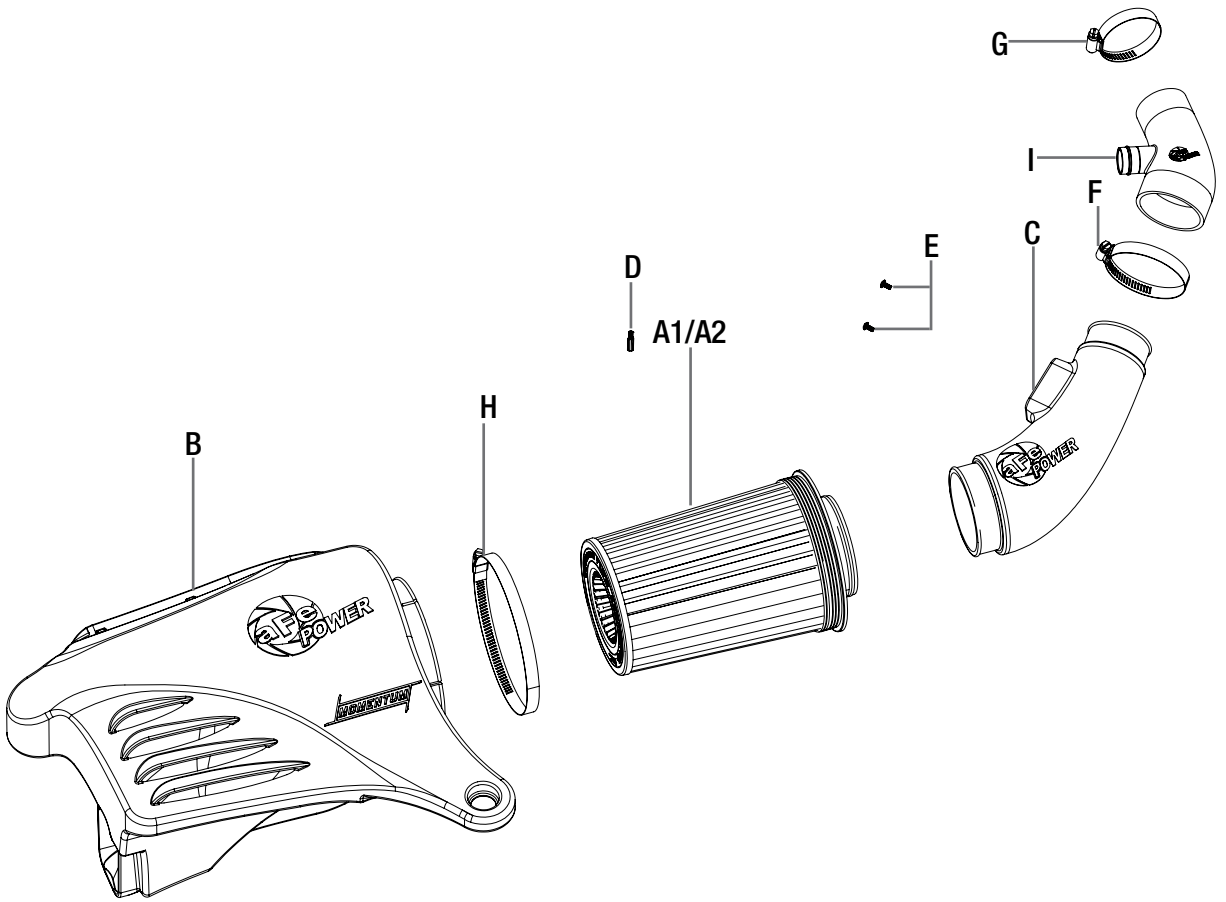



Figure A

Refer to Figure A for Steps 1-4

Step 1: Disconnect the Mass Air Flow (MAF) sensor harness.

Step 2: Unclip the hood latch cable of the airbox.

Step 3: Untighten the clamps on the factory intake tube at the turbo and the intake housing.

Step 4: Pull the factory airbox out of the vehicle by firmly pulling it out of its mounting grommet.



Refer to Figure B for Step 5

Step 5: Remove the intake tube off the turbo and disconnect the two hoses connected to it to remove the tube of the vehicle.

**Figure C****Refer to Figure C for Steps 6-7**

Step 6: Transfer one of the grommet of the factory airbox to aFe Power housing.

Step 7: Install the filter into the housing with the clamps. Do not tighten at his time.



Figure D

Refer to Figure D for Step 8

Step 8: Install the aFe Power Housing into the vehicle by firmly pushing it into the mounting grommets.



Refer to Figure E for Step 9

Step 9: Transfer the MAF sensor from the factory housing to the aFe Power tube. Secure it using the furnished M4 screws.



Figure F

Refer to Figure F for Step 10

Step 10: Install the clamps over the coupling. Do not tighten clamps yet.



Refer to Figure G for Step 11

Step 11: Install the coupling over the turbo and connect the two hoses to the aluminum fittings. Do not tighten clamps yet.



Figure H

Refer to Figure H for Steps 12-13

Step 12: Slide the aFe Power tube into the coupling then into the filter. Align the filter, tube and coupling then tighten all clamps.

**Figure I****Refer to Figure I for Steps 13-14**

Step 13: Reconnect the MAF sensor harness.

Step 14: Secure the hood latch cable into the slot on the aFe Power housing. The installation is now completed, enjoy your aFe Power air intake system.

NOTE: Check all bolts, clamps and connectors after 100-200 miles.



Pro DRY S Air Filter



P/N: 21-91056

Pro 5R Air Filter



P/N: 24-91056

Pro DRY S Restore Kit



P/N: 90-59999

Blue Squeeze Restore Kit



P/N: 90-50501

SCORCHER GT Module



P/N: 77-46324

Sprint Booster V3



P/N: 77-16302

aFe Motorsport T-Shirt



P/N: 40-30442-B (M)
40-30443-B (L)
40-30444-B (XL)