

**GT**  
**MOMENTUM™**

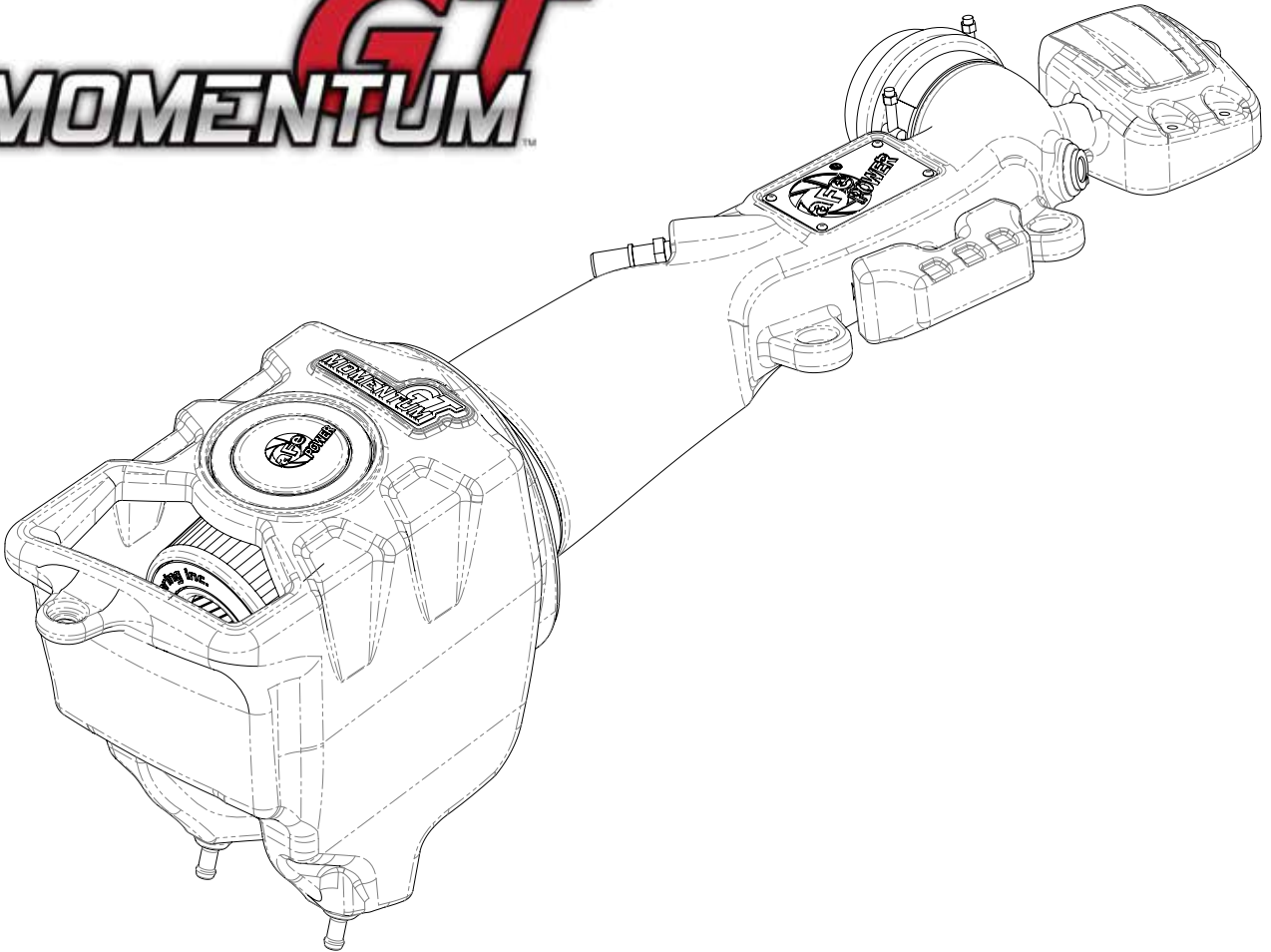

**advanced FLOW engineering** Momentum Air Intake

**Instruction Manual** P/N: 51-76217 / 54-76217 / 75-76217

Make: **Jeep** Model: **Wrangler (JL)** Year: **2018-2019** Engine: **V6-3.6L**



- Please read the entire instruction manual before proceeding.
- Ensure all components listed are present.
- Ensure you have all necessary tools before proceeding.
- Do not attempt to work on your vehicle when the engine is hot.
- Disconnect the negative battery terminal before proceeding.
- Retain factory parts for future use.

Label	Qty.	Description	Part Number
A1	1	Air Filter (Pro DRY S)	21-91126
A2	1	Air Filter (Pro 5R)	24-91126
A3	1	Air Filter (Pro GUARD 7)	72-91126
B	1	Tube	05-76217B1
C	1	Housing	05-76217B2
D	1	Coupling, Silicone Bellow	05-01480
E	2	Clamp, T-bolt	03-50292
F	1	Fitting, Vent Tube	05-01339
G	1	Grommet	03-50167
H	1	IAT Sensor Adaptor	05-01454

Tools needed: 8mm nut driver, 10mm deep socket and driver, 11mm deep socket or nut driver, panel popper tool, and needle nose pliers.

Note: Legal in California for use on race vehicles only. The use of this device on vehicles used on public streets or highways is strictly prohibited in California and others states that have adopted California emission regulations.

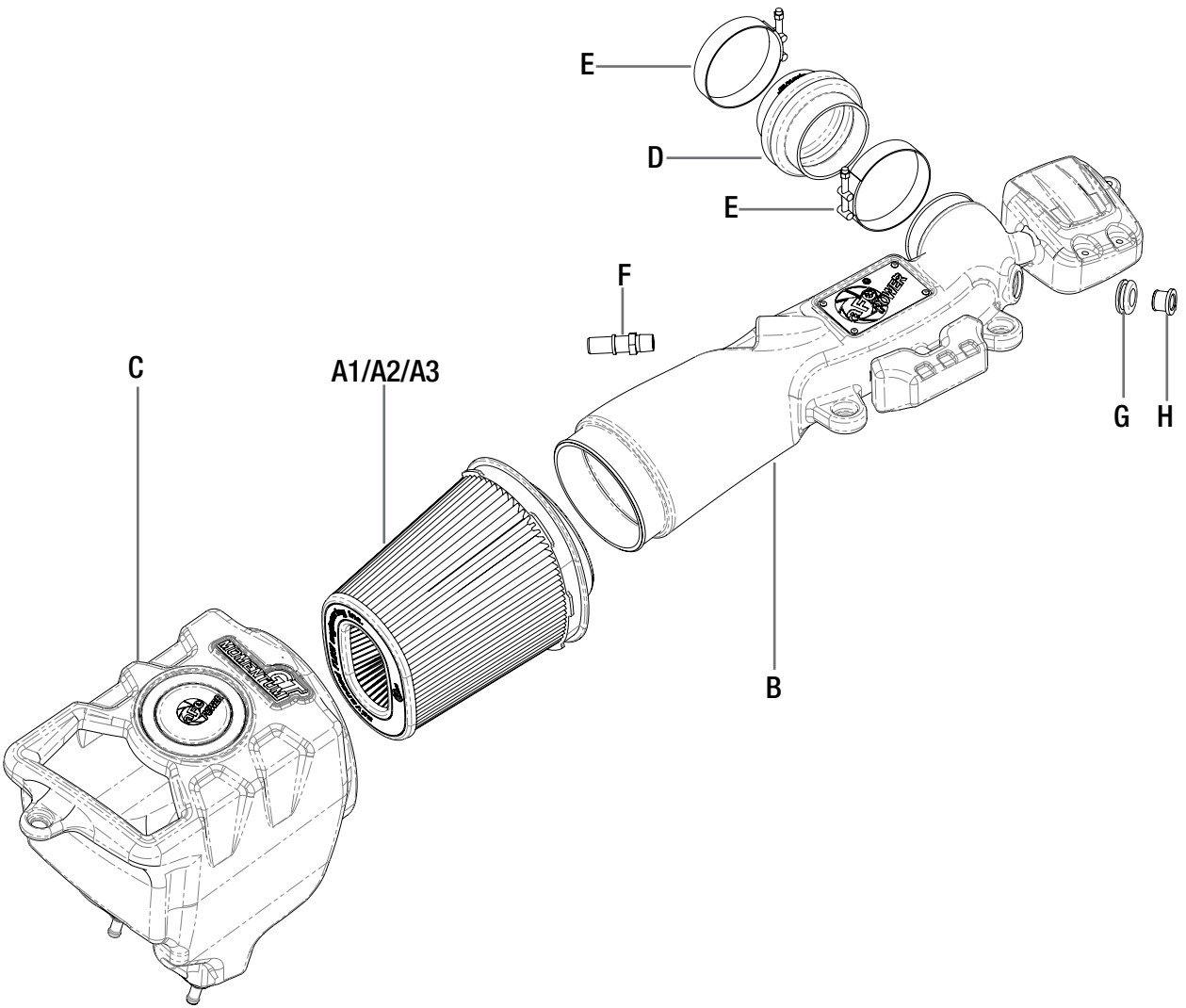

**Figure A****Refer to Figure A for Steps 1-2.**

Step 1: Remove the (3) bolts securing the intake to the vehicle using a 10mm socket and driver.

Step 2: Loosen the two clamps on the intake tube with an 8mm nut driver.

**Figure B****Refer to Figure B for Steps 3-5.**

Step 3: Disconnect the Crank Case Vent (CCV) by pushing on the grey clip and sliding the tube off the fitting.

Step 4: Disconnect the Intake Air Temperature (IAT) sensor.

Step 5: Remove the (2) connectors for the IAT sensor harness and the (1) connector for the coolant line from the right side of the intake tube. ①



**Refer to Figure C for Steps 6-8.**

Step 6: Remove the intake tube from the vehicle.

Step 7: Remove the housing from the vehicle by lifting straight upward. If the rubber grommets pop off with the housing, then remove them from the housing and place them back into the holes in the mounting bracket.

Step 8: If the connectors on the IAT sensor harness and the coolant line are bent out of shape, then repair them so that they look like the connector shown.





Figure D

**Refer to Figure D for Steps 9-13.**

- Step 9: Remove the metal sleeves and rubber grommets from the OE intake tube and reinstall them into the aFe intake tube. (2)
- Step 10: Install the grommet and temp sensor adaptor into the hole on the front of the intake tube. Make sure that the bead on the adaptor is positioned on correctly in the grommet so that it cannot pop out during use.
- Step 11: Carefully remove the IAT sensor from the OE intake tube by lifting up slightly on the plastic tab and rotating the sensor 1/4 turn counterclockwise.
- Step 12: Reinstall the IAT sensor into the temp sensor adaptor on the aFe intake tube and make sure to lock it into position by rotating it clockwise until the small tab clicks into place.
- Step 13: Install the aluminum fitting into the threaded insert on the tube and tighten it securely. Liquid Loctite or Teflon tape should be used to provide a proper seal. Do not over tighten the fitting. (3)



Figure E

**Refer to Figure E for Step 14.**

Step 14: Remove the metal sleeve and rubber grommet from the OE housing and reinstall them into the aFe housing as shown.





Figure F

**Refer to Figure F for Steps 15-16.**

- Step 15: Install the aFe housing into the vehicle by lining up the pegs into the grommets and then pressing down firmly to lock them into place. Use one of the bolts removed in Step 1 to secure the housing to the fender.
- Step 16: Install the aFe air filter into the housing and make sure that all the tabs on the filter lock into place on the housing. Leave the clamp very loose to ensure easy installation of the intake tube.

**Figure G**

**Refer to Figure G for Steps 17-22.**

- Step 17: Install the coupler onto the intake tube and place the clamps loosely over both ends of the coupler.
- Step 18: Insert the large end of the tube into the air filter and then rotate the coupler onto the throttle body. Make sure that the coolant line is routed on top of the intake tube before proceeding.
- Step 19: Connect the CCV to the aluminum fitting on the intake tube.
- Step 20: Plug in the IAT sensor and connect the harness to the two designated spots on the intake tube.
- Step 21: Connect the coolant line retaining clip to the designated spot on the intake tube.
- Step 22: Using the remaining bolts removed in Step 1, secure the intake tube to the core support.



Figure H

**Refer to Figure H for Steps 23-25.**

Step 23: Tighten all (3) clamps using an 11mm nut driver or a deep socket and driver. Do not over tighten the clamps.

Step 24: Verify that all connectors are secure and the (3) bolts are tightened properly.

Step 25: Your installation is now complete! Thank you for choosing aFe POWER!

**NOTE: Check all bolts, clamps, and hose connections after 100-200 miles.**

Rely on premium performance air intake systems by aFe if you're looking for quality and efficiency.