

GT
MOMENTUM™

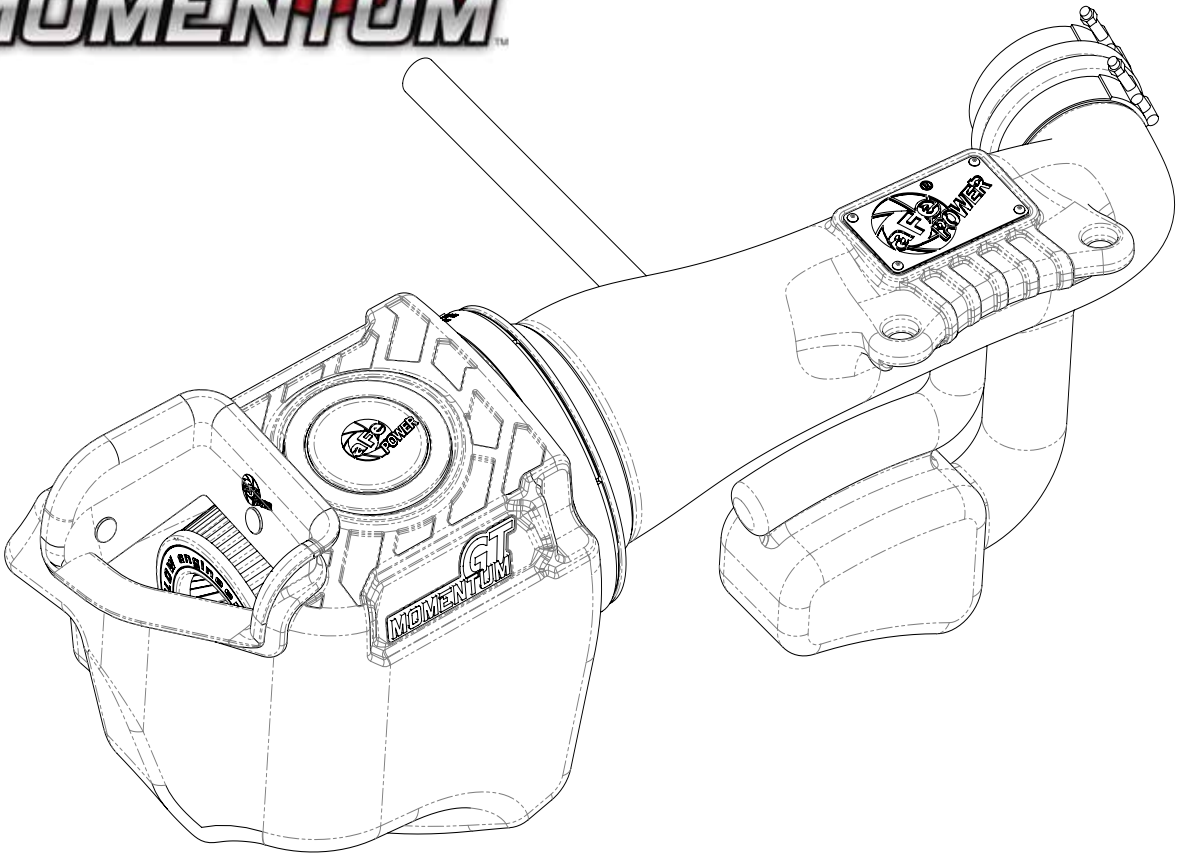

advanced FLOW engineering Momentum Air Intake

Instruction Manual P/N: 51-76212 / 54-76212 / 75-76212

Make: **Jeep** Model: **Wrangler (JK)** Year: **2012-2018** Engine: **V6-3.6L**



- Please read the entire instruction manual before proceeding.
- Ensure all components listed are present.
- Ensure you have all necessary tools before proceeding.
- Do not attempt to work on your vehicle when the engine is hot.
- Disconnect the negative battery terminal before proceeding.
- Retain factory parts for future use.

Label	Qty.	Description	Part Number
A1	1	Air Filter (Pro DRY S)	21-91125
A2	1	Air Filter (Pro 5R)	24-91125
A3	1	Air Filter (Pro GUARD 7)	72-911125
B	1	Tube	05-76212B1
C	1	Housing	05-76212B2
D	2	Clamp, T-bolt, (3-5/16-3-5/8)	03-50292
E	1	Clamp, T-bolt, (7-7.38)	03-50290
F	1	Coupler, Silicone Bellows	05-01400
G	1	Hose, Fuel: 5/8" (9" inches)	05-00069
H	1	Fitting, Air Temp Sensor	05-01454
I	1	Grommet, Rubber	03-50167

Tools needed: 8mm nut driver, 10mm nut driver or deep socket, 11mm nut driver or deep socket.

Note: Legal in California for use on race vehicles only. The use of this device on vehicles used on public streets or highways is strictly prohibited in California and others states that have adopted California emission regulations.

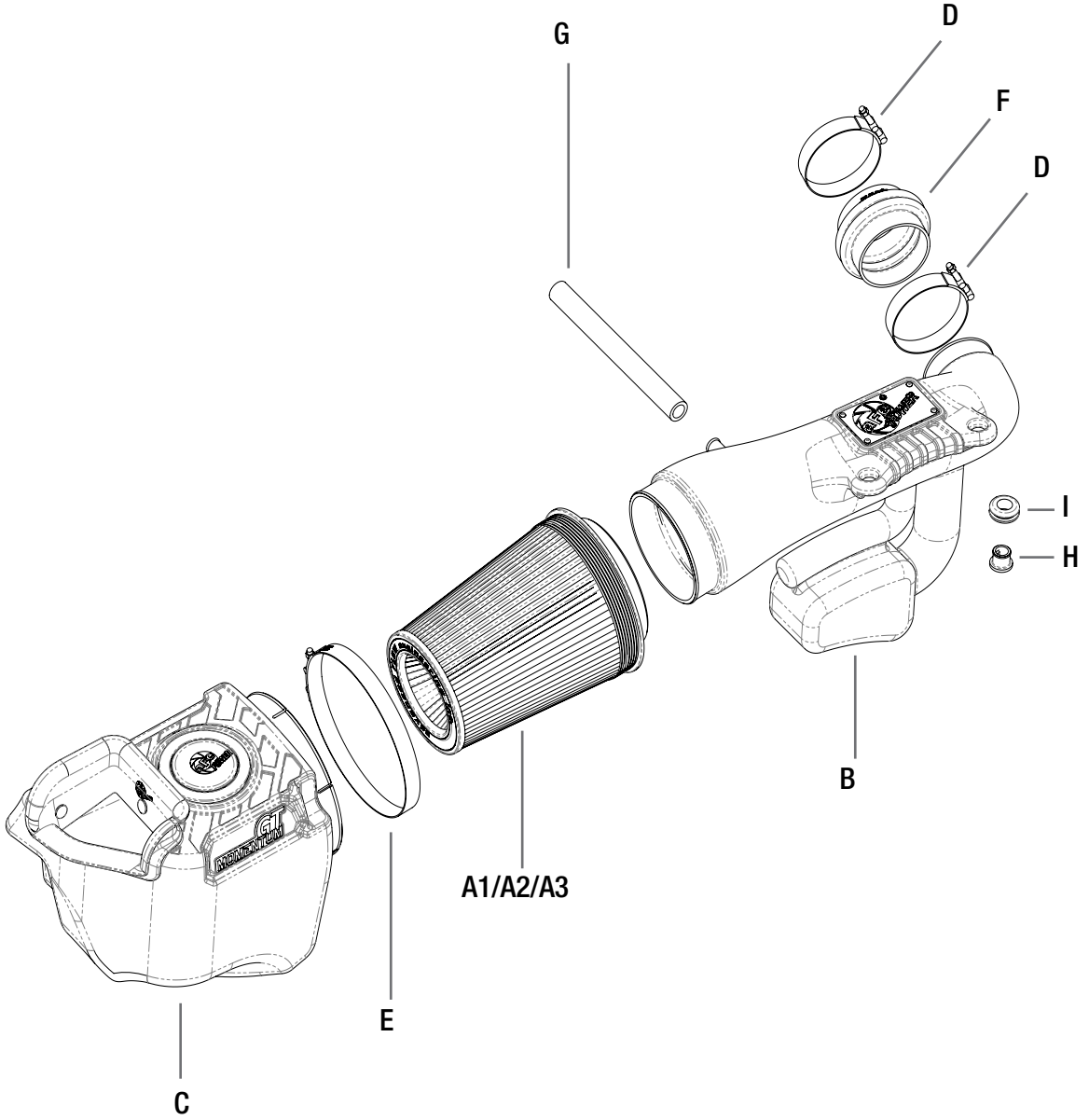



Refer to Figure A for Step 1

Step 1: Remove the engine cover by lifting firmly out of the vehicle.



Refer to Figure B for Steps 2-6

Step 2: Remove the two 10mm bolts from the intake tube. ①

Step 3: Disconnect the temp sensor wire harness. ②

Step 4: Loosen the hose clamp at the throttle body.

Step 5: Completely remove the small section of crankcase vent (CCV) hose. It should be pulled off of the air filter housing and the tube to the engine. ③

Step 6: Remove the stock intake tube, and air filter housing by pulling straight up and out of the vehicle.



Figure C

Refer to Figure C for Step 7

Step 7: Lift up on the small locking tab on the temp sensor, twist the sensor about 45 degrees counter-clockwise, and pull the sensor straight up to remove from stock intake tube.



Figure D

Refer to Figure D for Steps 8-10

Step 8: Install the large clamp loosely over the back of the air intake housing.

Step 9: Insert the aFe air filter into the housing and make sure the clamp is loose.

Step 10: Install the housing with the air filter into the rubber grommets.



Figure E

Refer to Figure E for Steps 11-13

Step 11: Install the grommet into the intake tube.

Step 12: Insert the plastic temp sensor adaptor into the grommet.

Step 13: Install the temp sensor into the plastic adaptor, and make sure the plastic tab locks into place.



Figure F

Refer to Figure F for Steps 14-15

Step 14: Remove the metal sleeves and rubber grommets from the OE intake tube and reinstall them into the new aFe intake tube as shown.

Step 15: Place the small t-bolt clamps loosely over the silicone coupler and slide the coupler onto the end of the intake tube.

**Figure G****Refer to Figure G for Steps 16-18**

Step 16: Route the coolant overflow line above the fan shroud as shown. ④

Step 17: Insert the large end of the tube into the aFe filter and plug in the temperature sensor.

Step 18: Install the coupler end of the intake tube over the throttle body.



Figure H

Refer to Figure H for Steps 19-21

Step 19: Install the new CCV hose provided between the intake tube and the hard plastic tube. ⑤

Step 20: The coolant overflow line should sit just under the mounting tabs on the intake tube.

Step 21: Secure the tube to the fan shroud with the two bolts removed previously.



Figure 1

Refer to Figure 1 for Steps 22-23

Step 22: Tighten all four of the clamps at this time.

Step 23: Reinstall the engine cover. Your installation is now complete.

NOTE: Check all bolts, clamps, and hose connections after 100-200 miles.

Rely on premium performance air intake systems by aFe if you're looking for quality and efficiency.