

advanced FLOW engineering

Instruction Manual P/N: 51-76202/54-76202/75-76202

Make: **Jeep** Model: **Wrangler (TJ)** Year: **1997-2006** Engine: **I6-4.0L**



- Please read the entire instruction manual before proceeding.
- Ensure all components listed are present.
- If you are missing any of the components, call customer support.
- Ensure you have all necessary tools before proceeding.
- Do not attempt to work on your vehicle when the engine is hot.
- Disconnect the negative battery terminal before proceeding.
- Retain factory parts for future use.

Label	Qty.	Description	Part Number
A1	1	Air Filter Pro-5R (Blue Media)	24-91089
A2	1	Air Filter Pro DRY S	21-91089
A3	1	Air Filter Pro GUARD 7 (Yellow Media)	72-90084
B	1	Tube	05-76202B1
C	1	Housing	05-76202B2
D	2	Clamp (2-9/16" - 3-1/2")	03-50007
E	1	Grommet, Air Temp Sensor	03-50033
F	1	ISO Mount	03-50022
G	2	Clamp - Mini (9/16" - 1-1/16")	03-50078
H	2	Screw, Hex Head: M6 x 1 x 25	03-50114
I	5	Washer, Fender: 1/4" (1" OD)	03-50074
J	3	Nut, Hex Nylon Lock: M6 x 1.0	03-50185
K	1	Clamp, T-Bolt (6-5/16" - 6-5/8") (SS)	03-50266
L	1	Hose, Fuel ID, Black (10") 5/8"	05-00069
M	1	Coupling, Reducer	05-00824
N	1	Plug, Urethane	05-01202

Tools Needed: 8mm, 10mm, and 13mm sockets, 1/4" and 8mm nut drivers or flat blade screwdriver, 10mm wrench, pliers.

Note: CARB approved. CARB EO # D-550-14

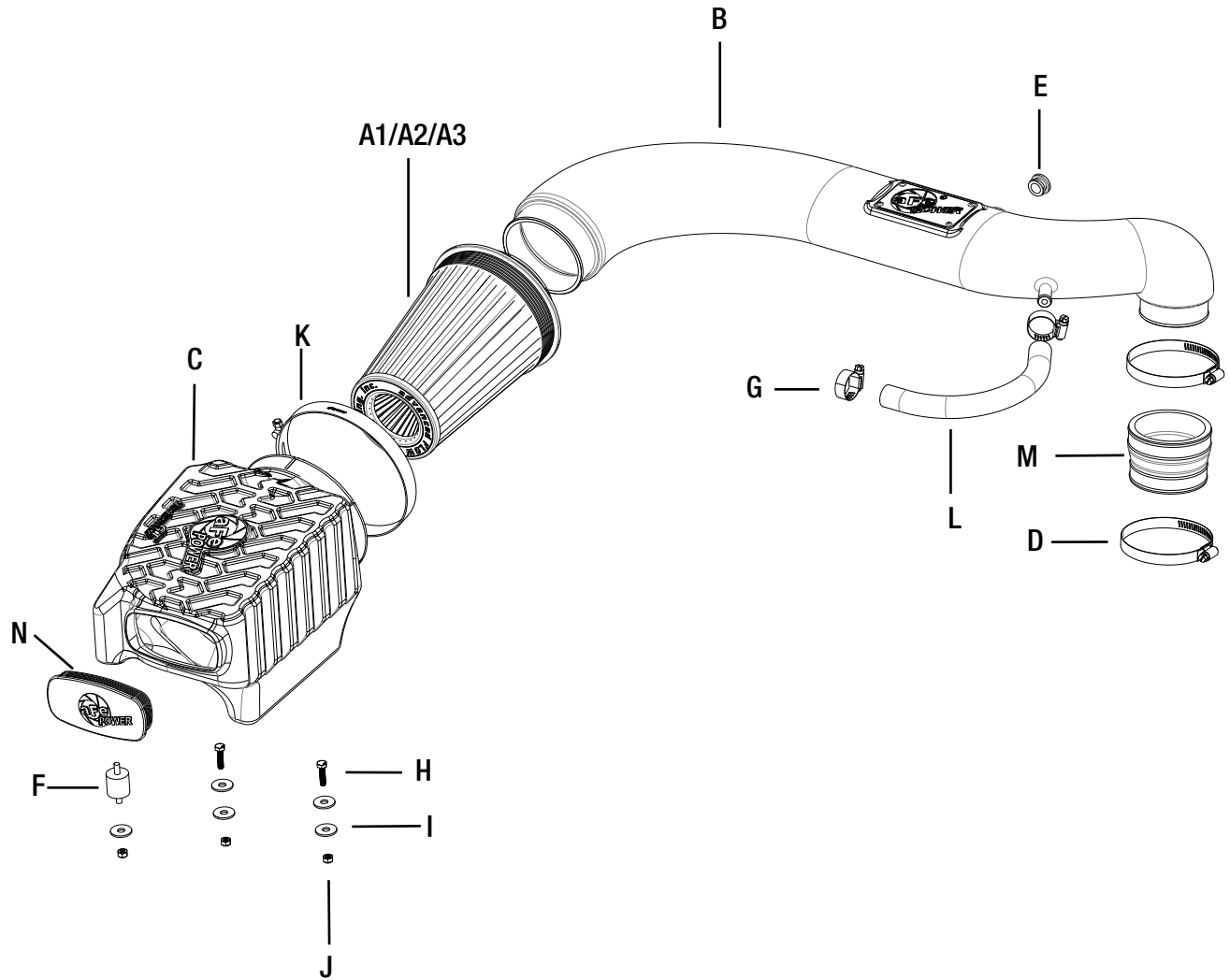

**Figure A****Refer to Figure A for Step 1-3**

Step 1: Loosen the clamps on the intake tube using an 8mm nut driver.

(2004-2006 Models only): Disconnect the temperature sensor harness located on the back side of the intake tube.

Step 2: Completely remove the Crank Case Vent (CCV) hose from the vehicle.

Step 3: Remove the intake tube.

REMOVAL



Figure B

Refer to Figure B for Steps 4-5

Step 4: Unclip the top of the air box and remove it from the vehicle.

Step 5: Remove the OE air filter from the lower half of the air box.



Figure C

Refer to Figure C for Steps 6-8

Step 6: Remove the small round cross bar that goes from the front radiator support to the fire wall on the passenger side.

Step 7: Using an 8mm socket, loosen all three of the screws on the bottom of the air box.

Step 8: Pull the lower half of the factory air box out of the vehicle.



Figure D

Refer to Figure E for Steps 9-10

Step 9: Remove the bolts from the factory air box.

Step 10: Press out the metal sleeves from (2) two of the grommets and then remove the (2) two grommets completely.

**Figure E****Refer to Figure D for Steps 11-13**

FOR 2004-2006 MODELS EQUIPT WITH TEMP SENSOR ONLY! IF TEMP SENSOR IS NOT EQUIPT THEN SKIP TO FIGURE F!

- 11: Remove the temp sensor from the back of your factory intake tube by rotating it counterclockwise and pulling it out. Be careful not to break the small tab that locks the sensor in place.
- 12: Drill out an 11/16" diameter hole in the back of the new aFe intake tube in the location shown in the picture. Deburr all sharp edges.
- 13: Insert the supplied grommet into the hole, and then press your temp sensor into the grommet.

**Figure F****Refer to Figure F for Steps 14-15**

Step 14: Install the grommets into the two locations shown in the picture and insert the metal sleeves from inside of the housing so that the flat part is on the inside.

Step 15: Insert the rubber isolation mount into the threaded insert on the bottom of the housing and tighten by hand.

**Figure G****Refer to Figure G for Steps 16-17**

Step 16: Install the new housing into the vehicle and make sure that the rubber isolation mount lines up with the slotted hole on the fender well. Insert the two M6x1x25mm furnished bolts with two flat washers through the grommets on the inside of the housing.

Step 17: Place a flat washer and then a nut on all three bolts that pass through the fender well. Tighten the housing in place, but do not over-tighten the isolation mount.



Figure H

Refer to Figure H for Steps 18-19

Step 18: Install the large clamp over the back side of the flange on the housing.

Step 19: Install the filter with clamp into the back of the housing. (Note: if this interface slips apart, then acetone can be applied to both the filter and housing in this area to remove and mold release oil that is causing it to slip.)

Figure I

Refer to Figure I for Steps 17-20

Step 17: Slide the two smaller clamps onto the coupling and then install the coupling, with the small diameter side facing down, onto the throttle body. Do not tighten any of the clamps yet.

Step 18: Install the intake tube into the back of the filter and then rotate it down into the coupling located on the throttle body side. Position all of the parts so that they are lined up and then tighten all 4 clamps.

FOR 2004-2006 MODELS EQUIPT WITH TEMP SENSOR ONLY:

Step 19: Plug in the temp sensor wire.

Step 20: Slide the two smallest clamps over each end of the supplied vent hose. Connect the new vent hose to the CCV port and to the port on the intake tube and tighten both clamps.



Figure J

Refer to Figure J for Steps 21-22

Step 21: Reinstall the cross bar that goes from the firewall to the radiator support. Tighten both bolts.

Step 22: If desired, the urethane plug can be installed to reduce some of the intake noise. Your installation is now complete.

NOTE: Retighten all connections after approximately 100-200 miles.

Place enclosed CARB EO sticker on or near the device on a smooth, clean surface.

EO identification label is required to pass the smog inspection.



Pro DRY S Air Filter



P/N: 21-91089

Pro 5R Air Filter



P/N: 24-91089

Pro GUARD 7 Air Filter



P/N: 72-90084

Blue Squeeze Restore Kit



P/N: 90-50501

Blue Aerosol Restore Kit



P/N: 90-50001

Gold Aerosol Restore Kit



P/N: 90-50000

Gold Squeeze Restore Kit



P/N: 90-50500

Pro DRY S Restore Kit



P/N: 90-59999

Cat-Back Exhaust



P/N:49-46229

Oil Filter



P/N: 44-LF008

aFe Power Hat



P/N: 40-10083

Warranty

General Terms:

- aFe warrants their products to be free from manufacturer's defects due to workmanship and material.
- This warranty applies only to the original purchaser of the product and is nontransferable.
- Proof of purchase of the aFe product is required for all warranty claims.
- Warranty is valid provided aFe instructions for installation and/or cleaning were properly followed.
- Proper maintenance with regular inspections of product is required to insure warranty coverage.
- Damage due to improper installation, abuse, unauthorized repair or alteration is not warranted.
- Incidental or consequential damages or cost, including installation and removal of part, incurred due to failure of aFe product is not covered under this warranty.
- All warranty is limited to the repair and/or replacement of the aFe part. To request Return Goods Authorization ("RGA"). Upon receipt of the RGA, you must return the product to the address provided in the RGA, freight prepaid and accompanied with a dated proof of purchase and the RGA. Upon receipt of the defective product and upon verification of proof of purchase, aFe will either repair or replace the defective product within a reasonable time, not to exceed thirty days.

Product Category	P/N Prefix	Warranty duration
Direct OE Replacement Filters	10, 11, 30, 31, 71, 73	Life of the vehicle
Racing Filters	18	1 year
Universal	21, 24, 72	2 years
Air Intake Systems	50, 51, 54, 55, 75	2 years
Exhaust Systems	49	2 years
Intercoolers & Intercooler Tubes	46-2	2 years
Intake Manifolds	46-1	2 years
Differential Cover	46-7	Life of the vehicle
Exhaust Manifolds	46	2 years
Throttle Body Spacers	46-3	2 years
Fluid Filters	44	90 days
Pre-Filters	28	2 years
Heavy Duty OE Replacement	70	2 years
PowerSports OE Replacement	81, 87	2 years
PowerSports Intake Systems	85	2 years

No other warranty expressed or implied applies nor is any person or advanced FLOW engineering authorized to assume any other warranty. Some States do not allow the exclusion or limitation of incidental or consequential damages or do not allow limitations on how long an implied warranty lasts, so the above limitations or exclusions may not apply to you. This warranty gives you specific legal rights, and you may also have other rights which vary from State to State.