

advanced FLOW engineering

Instruction Manual P/N: 51-76008 / 54-76008 / 75-76008

Make: **Toyota** Model: **Land Cruiser (70 Series)** Year: **2009-2017** Engine: **V6-4.0L**



- Please read the entire instruction manual before proceeding.
- Ensure all components listed are present.
- Ensure you have all necessary tools before proceeding.
- Do not attempt to work on your vehicle when the engine is hot.
- Disconnect both the negative battery terminal before proceeding.

Retain factory parts for future use.

Label	Qty.	Description	Part Number
A1	1	Pro DRY S (Gray Media)	21-91109
A2	1	Pro 5R (Blue Media)	24-91109
A3	1	Pro-GUARD 7 (Gold Media)	72-91109
B	1	Tube	05-76008B1
C	1	Housing	05-76008B2
D	1	Plug, Urethane	05-00937
E	1	Coupling, Silicone Reducer	05-01400
F	1	Clamp, T-bolt (3-1/4" - 3-9/16")	03-50292
G	1	Seal Trim (23" inches)	05-00007
H	1	Clamp, T-bolt (3-1/16" - 3-3/8")	03-50320
I	2	Screw, Torx: M4	03-50491
J	1	Fitting, Nipple, Brs Hose	03-50191
K	1	Hose, Vacuum (20" inches)	05-00122
L	1	Mount, Rubber	03-50534
M	1	Hose, Fuel (24" inches)	05-00069
N	1	Clamp, T-bolt (8-5/16" - 8-5/8")	03-50267
O	2	Clamp, Mini #010	03-50078

Installation will require the following tools:

10mm & 8mm nut drivers, pliers, T20 & T30 drivers, 10mm & 11mm deep socket & driver, flathead screwdriver, phillips screwdriver and 7/16" wrench.

Note: Not legal for use in California. The use of this device in any on-road or off-road vehicles registered with the California Dept of Motor Vehicles (DMV) is strictly prohibited.

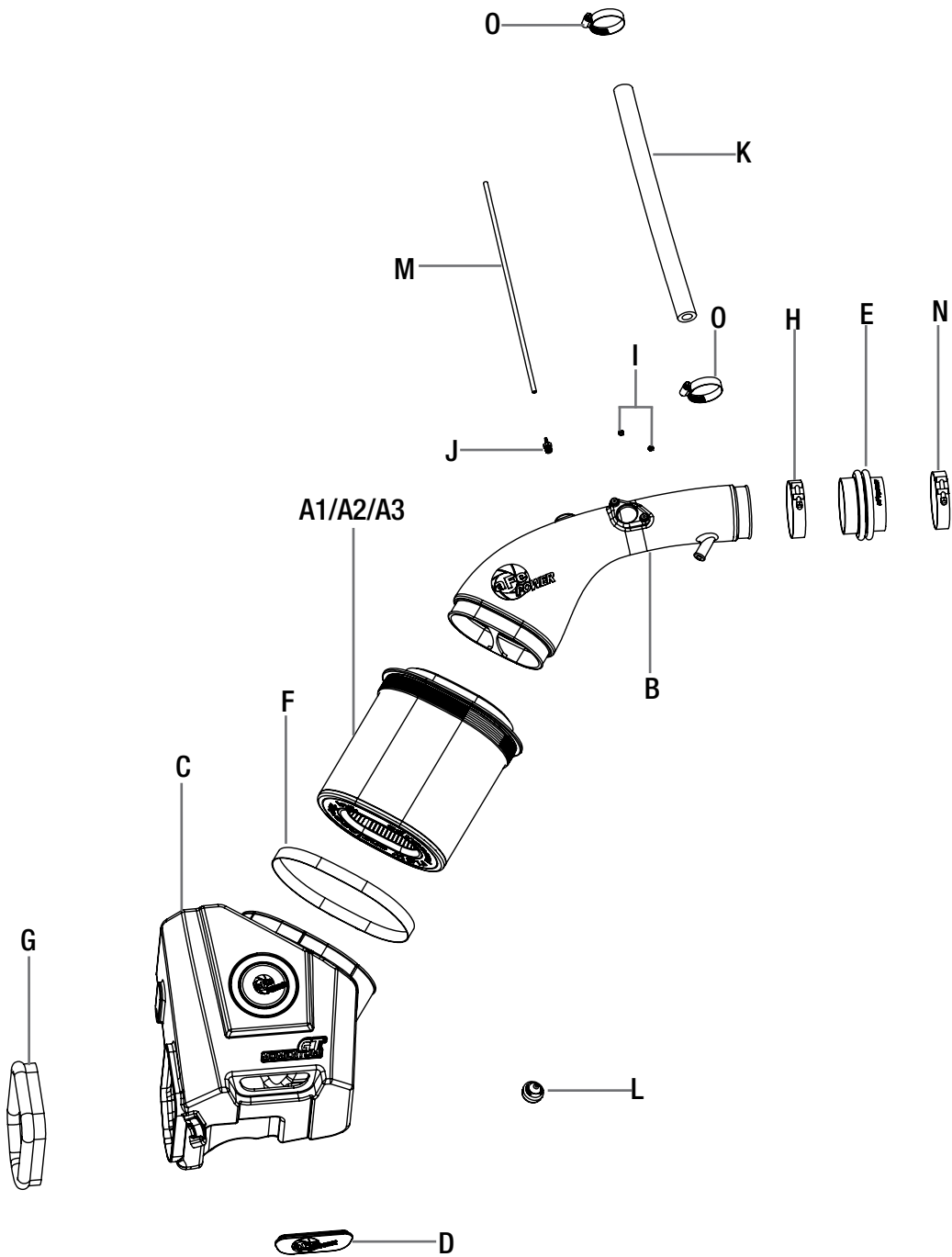



EARLIER MODELS



LATER MODELS

Figure A

Refer to Figure A

NOTE: The earlier Land Cruiser models have the factory airbox on top on the engine while the later models have the factory airbox on the passenger side. The aFePower air intake system is designed to fit both models. The installation may differ a little for the different models.



Figure B

Refer to Figure B for Step 1

We Will start with the earlier Land Cruiser, jump to Figure F, Step 9 for the later Land Cruiser.

Step 1: Remove the 2 nuts securing the engine cover. Then remove the engine cover. It won't be re-install with the aFePower intake.

**Figure C****Refer to Figure C for Steps 2-3**

Step 2: Remove the factory inlet tube, by untightening the clamps securing the tube.

Step 3: Remove the 3 screws securing the bracket holding the tube to the side fender, then remove the tube and bracket. Those screws will be re-used to install the aFe Power Housing.

REMOVAL



Figure D

Refer to Figure D for Step 4

Step 4: Remove the screw holding the black sheet metal blocking the opening in the fender, then remove the plate to allows more air coming in.

**Figure E****Refer to Figure E for Steps 5-8**

- Step 5: Disconnect the Mass Air Flow (MAF) Sensor harness and unclip it from the factory airbox.
- Step 6: Disconnect the vacuum hose next to the throttle body on the factory airbox. The hose will be re-used with the factory intake.
- Step 7: Disconnect the small hose connecting to the back for the factory airbox (by the firewall). This hose will be replaced by a longer hose furnished.
- Step 8: Remove the two screws securing the factory airbox, untighten the clamp at the throttle body then pull the airbox assembly out of the vehicle. The grommet on the factory airbox will be re-used with the aFePower airbox.



Figure F

Refer to Figure F for Steps 9-12

For the later Models, skip those Steps for the earlier Models and jump to Figure H, Step 14.

- Step 9: Disconnect the Mass Air Flow (MAF) Sensor harness and unclip it from the factory airbox.
- Step 10: Disconnect the big and small vacuum hoses connected to the tube resonance chamber. Those hoses will be replaced.
- Step 11: Remove the 3 screws securing the factory airbox to the fender. One of the screw may need to be removed from the bottom of the vehicle. Those screws and grommet will be re-used to install the aFe Power airbox.
- Step 12: Untighten the clamp at the throttle body then remove the factory tube and assembly outside of the vehicle. Remove the also the two vacuum hoses.



Refer to Figure G for Step 13

Step 13: Remove the plate blocking the air inlet by removing the three screws. This will allow more air to come in.

**Figure H****Refer to Figure H for Steps 14-16**

For earlier and later models:

Step 14: Transfer the two grommets from the factory airbox to the aFe Power Housing.

Step 15: Install the provided trim seal on the opening of the aFe Power housing. Make sure it is fully pushed and secured on the edge of the housing.

Step 16: Install the larger clamp on the housing big opening, do not fully tighten the clamp yet.



Refer to Figure I for Steps 17-18

Step 17: Transfer the rectangular grommet from the factory airbox (later models) or inlet tube (earlier models) to the bottom of the aFe Power housing.

Step 18: Install the provided stand-off grommet into the hole at the bottom of the factory housing.



Figure J

Refer to Figure J for Step 19

Step 19: Install the aFepower housing into the vehicle. Secure it using the screws from the factory airbox (later models) or from the factory inlet bracket (earlier models). One of the screw goes inside the housing, the other one goes on the bracket toward the front of the vehicle.



Figure K

Refer to Figure K for Step 20

Step 20: Slide the aFe Power filter inside the housing with the clamp installed. Do not tighten yet.

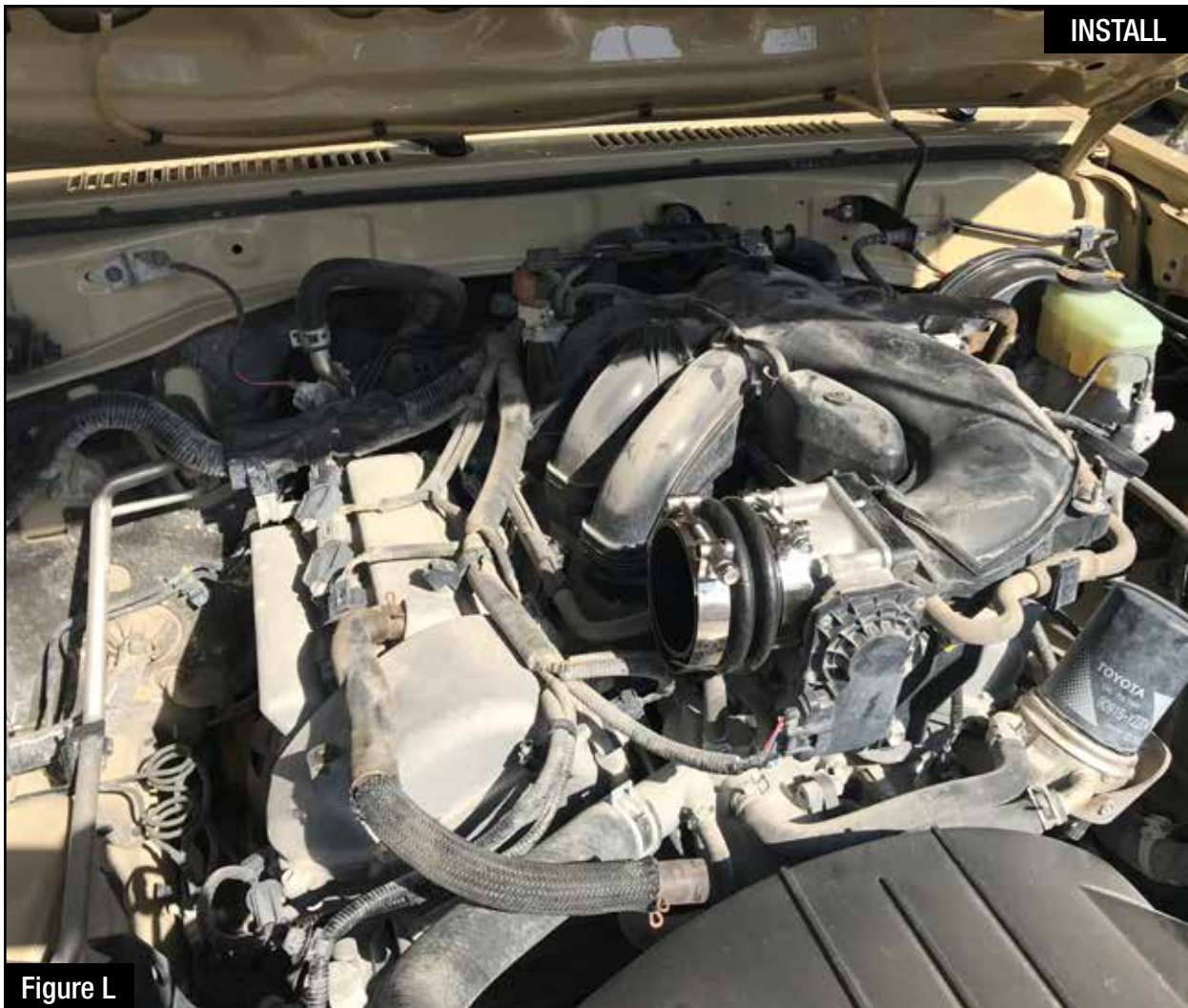

Figure L

Refer to Figure L for Step 21

Step 21: Install the coupling with clamps on the throttle body. This is a reducer coupling; the throttle body side is the smaller side. The clamps are also different size and the smaller one goes on the throttle body side. Do not tighten yet.

**Figure M****Refer to Figure M for Steps 22-23**

Step 22: Remove the MAF sensor from the factory housing and install it on the aFe Power tube. Use the furnished screws to secure it to the tube.

Step 23: Install the brass nipple fitting onto the NPT insert on the tube. Firmly tighten.

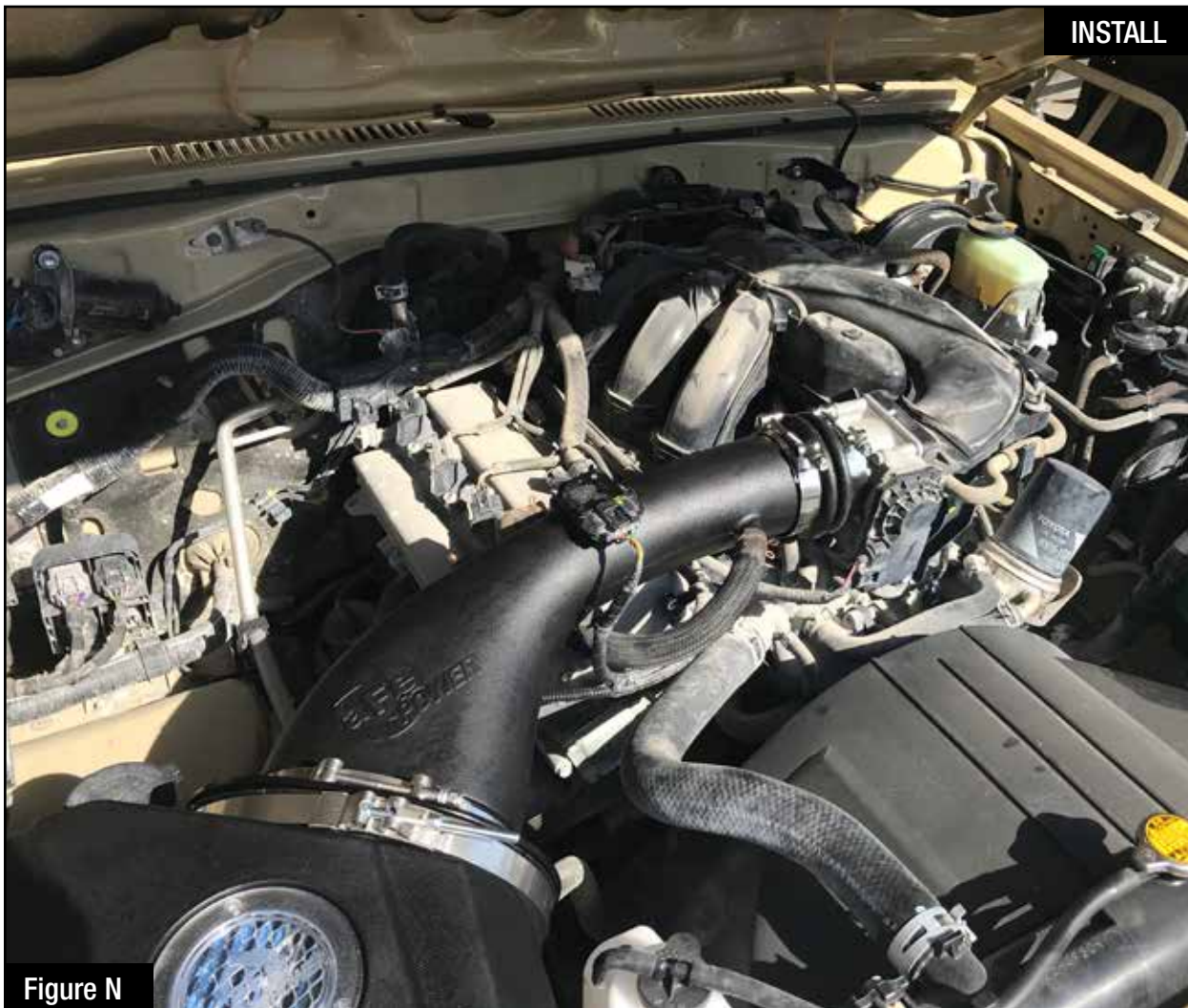

Figure N

Refer to Figure N for Steps 24-26

Step 24: Install the tube into the vehicle by sliding in the filter side first, then the tube into the coupling on the throttle body. Align the tube correctly, then tighten all clamps.

Step 25: Reconnect the MAF sensor harness.

Step 26: For the earlier models, connect the big vacuum hose to the tube directly using the factory clamp, for the later models replace this hose with the hose provided and secure it with the mini clamps also provided.



Figure 0

Refer to Figure 0 for Steps 27

Step 27: Install the provided small hose between the engine connection and the brass fitting on the aFe Power tube.

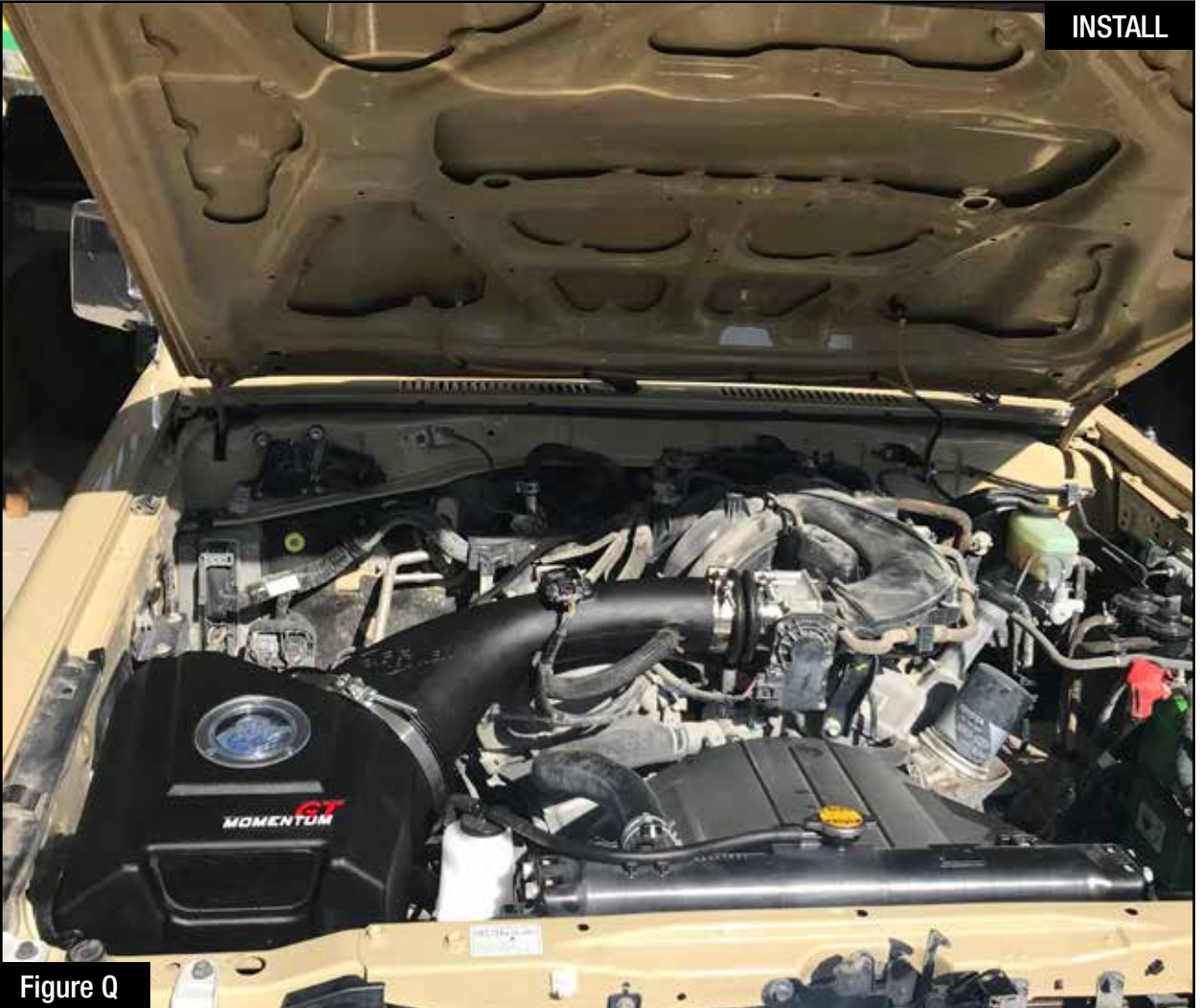

Figure P

Refer to Figure P for Step 28

Step 28: The kit includes an optional plug to close off the front auxiliary air inlet. Install the plug if you wish to close off the front auxiliary air inlet and only capture cold air from the side fender.

- Without the plug installed, the aFe Power intake will capture the maximum air available. More airflow offers more power. Yet some of this air is picked up from inside the engine compartment and could be warmer air. Warmer air will affect the performance of the vehicle.
- The plug installed on the housing will block off any hot engine air entering the housing and make sure the coolest air available is directed into the engine. It will also reduce the noise of the intake.

**Figure Q****Refer to Figure Q for Step 29**

Step 29: Verify all connections are secured. The installation is now completed, enjoy your aFe Power air intake system.

NOTE: Check all bolts, clamps and connectors after 100-200 miles.



Pro DRY S Air Filter



P/N: 21-91109

Pro 10R Air Filter



P/N: 20-91109

Pro-GUARD 7 Air Filter



P/N: 72-91109

Pre-Filter



P/N: 28-10283

Pro DRY S Restore Kit



P/N: 90-59999

Blue Squeeze Restore Kit



P/N: 90-50501

Gold Squeeze Restore Kit



P/N: 90-50500