

**advanced FLOW engineering**

**Instruction Manual** P/N: 51-76005 / 54-76005 / 75-76005

Make: **Toyota** Model: **Tacoma** Year: **2016-2017** Engine: **V6-3.5L**



- Please read the entire instruction manual before proceeding.
- Ensure all components listed are present.
- If you are missing any of the components, call customer support.
- Ensure you have all necessary tools before proceeding.
- Do not attempt to work on your vehicle when the engine is hot.

## Retain factory parts for future use.

Label	Qty.	Description	Part Number
A1	1	Air Filter (Pro 5R)	24-91092
A2	1	Air Filter (Pro DRY S)	21-91092
A3	1	Air Filter (Pro-GUARD 7)	72-91092
B	1	Tube	05-76005B1
C	1	Housing	05-76005B2
D	2	Clamp, #052	03-50008
E	1	Coupling, Silicone Reducer	05-01400
F	2	Screw, Torx: M4x.7x8mm	03-50491
G	1	Seal, Trim (15" in.)	05-00007
H	1	Plug, Urethane	05-01202

Installation will require the following tools:

8mm nut driver, 10mm deep socket & driver, 12mm deep socket & driver, 7/16" deep socket, phillips screwdriver, T20 torx screwdriver.

Note: Legal in California for use on race vehicles only. The use of this device on vehicles used on public streets or highways is strictly prohibited in California and others states that have adopted California emission regulations.

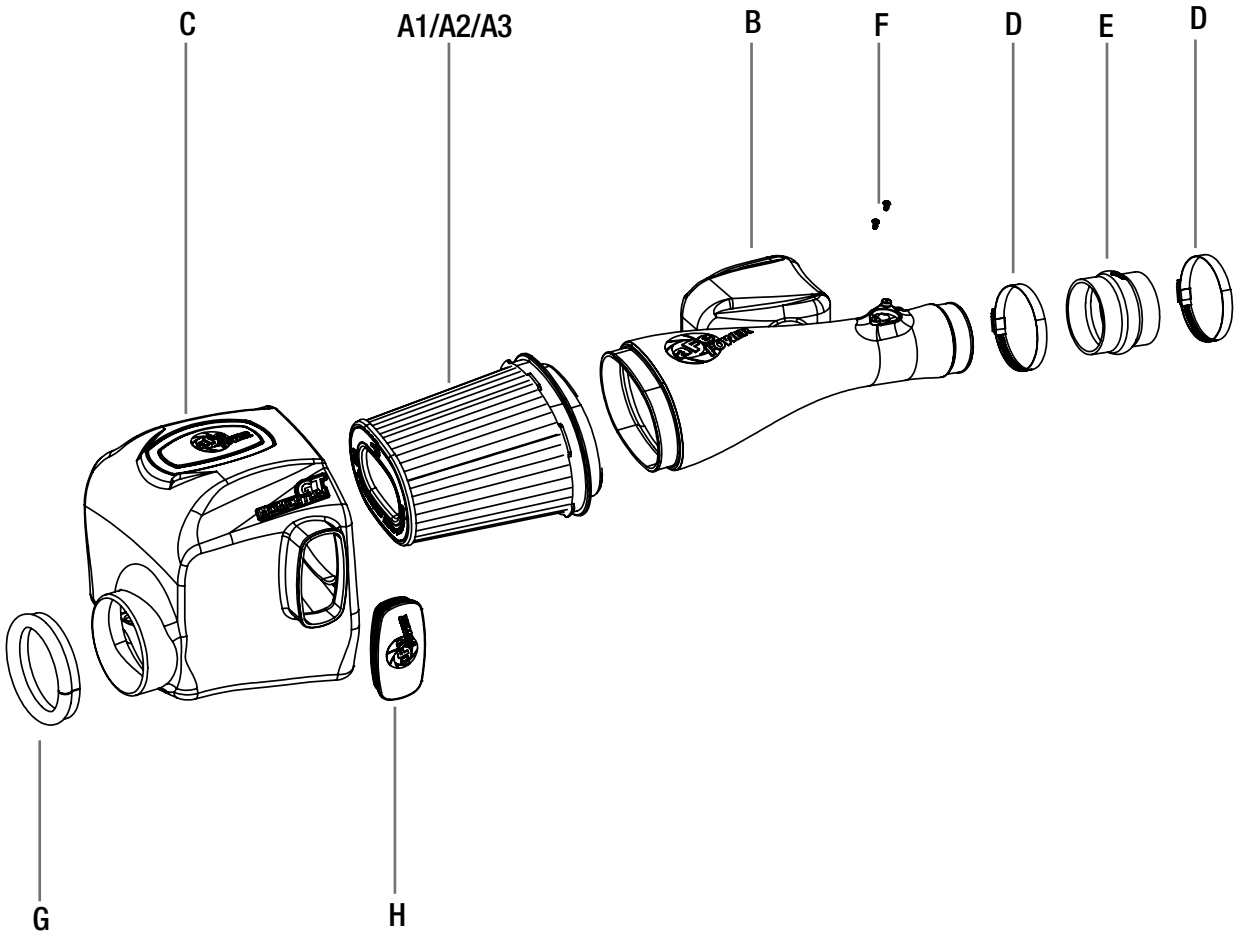



Figure A

**Refer to Figure A for Step 1**

Step 1: Remove the engine cover by lifting the front up and pulling the cover towards you.



Figure B

**Refer to Figure B for Steps 2-4**

Step 2: Disconnect the Mass Air Flow (MAF) harness (1) from the sensor in the factory tube.

Step 3: Disconnect the MAF wiring harness from both plastic clips (2).

Step 4: Disconnect the Crank Case Vent (CCV) hose (3) from the factory intake tube.

**\*Optional: save the factory spring clip for later use.**

**Figure C****Refer to Figure C for Steps 5-8**

Step 5: With a 10mm nut driver, loosen the hose clamp at the throttle body (4).

Step 6: Unclip both toggle clamps on the factory housing (5).

Step 7: Lift and remove the upper intake housing and intake tube at this time.

Step 8: Remove the factory air filter.

**Figure D****Refer to Figure D for Steps 9-10**

Step 9: With a 12mm nut driver, loosen all three (6) bolts securing the lower housing in place.

Step 10: Lift and remove the lower half of the factory housing at this time.



Figure E

**Refer to Figure E for Step 11**

Step 11: Remove and transfer the three steel sleeves and three rubber isolation grommets to the Momentum housing (7).





Figure F

**Refer to Figure F for Step 12**

Step 12: Install the rubber trim seal on the round fender-side opening of the Momentum housing.

**Note: Get one end seated on the housing first then slowly work all the way around, pressing it onto the housing as you go.**

**Figure G****Refer to Figure G for Step 13**

Step 13: Using a phillips head screwdriver, remove the MAF sensor (8) and transfer to the Momentum intake tube. Secure MAF sensor using the two provided T20 Torx screws.



Figure H

**Refer to Figure H for Steps 14-15**

- Step 14: Before installing the Momentum housing, insert two previously removed bolts into the rubber grommets from the inside and one on the outer mounting location.
- Step 15: Lower the housing into the engine bay, align each bolt and tighten. Careful not to over tighten.



Figure I

**Refer to Figure I for Steps 16-17**

Step 16: Insert the filter into the housing as shown (9). Press until you feel or hear all 6 of the tabs seat themselves in the housing. Gently pull on the filter to verify it is properly seated.

Step 17: Slide the coupling over the throttle body as shown, smaller end on the throttle body (10).



Figure J

**Refer to Figure J for Steps 18-21**

- Step 18: Insert the tube into the air filter as shown then lower the other end into the coupling at the throttle body.
- Step 19: Slip both provided hose clamps over the coupling as shown (11).
- Step 20: Align the tube with the coupling and filter then tighten both clamps at the throttle body with an 8mm nut driver.
- Step 21: Tighten the t-bolt clamp on the filter securing it to the intake tube (12).



Figure K

**Refer to Figure K for Steps 22-23**

Step 22: Reconnect the CCV hose to the intake tube (13), followed by the factory spring clip.

Step 23: Reconnect the MAF sensor as shown (14).



Figure L

**Refer to Figure L for Step 24**

Step 24: Reinstall engine cover. Your installation is now complete.

**NOTE: Check all bolts, clamps and connectors after 200 miles.**



Pro DRY S Air Filter



P/N: 21-91092

Pro 5R Air Filter



P/N: 24-91092

Pro-GUARD 7 Air Filter



P/N: 72-91092

Blue Squeeze Restore Kit



P/N: 90-50501

Pro DRY S Restore Kit



P/N: 90-59999

Gold Squeeze Restore Kit



P/N: 90-50500

Coilovers



P/N: 101-5600-03 (Front)

Shocks



P/N: 102-005-201 (Rear)

Cat-Back Exhaust System



P/N: 49-46026-B (Blk Tip)  
49-46026-P (Pol Tip)

Side-Exit Exhaust System



P/N: 49-46032-B (Blk Tips)  
49-46032-P (Pol Tips)

aFe T-Shirt



P/N: 40-30382 (M)  
40-30383 (L)  
40-30384 (XL)



# Warranty

## General Terms:

- aFe warrants their products to be free from manufacturer's defects due to workmanship and material.
- This warranty applies only to the original purchaser of the product and is non-transferrable.
- Proof of purchase of the aFe product is required for all warranty claims.
- Warranty is valid provided aFe instructions for installation and/or cleaning were properly followed.
- Proper maintenance with regular inspections of product is required to insure warranty coverage.
- Damage due to improper installation, abuse, unauthorized repair or alteration is not warranted.
- Incidental or consequential damages or cost, including installation and removal of part, incurred due to failure of aFe product is not covered under this warranty.
- All warranty is limited to the repair and/or replacement of the aFe part. To request Return Goods Authorization ("RGA"). Upon receipt of the RGA, you must return the product to the address provided in the RGA, freight prepaid and accompanied with a dated proof of purchase and the RGA. Upon receipt of the defective product and upon verification of proof of purchase, aFe will either repair or replace the defective product within a reasonable time, not to exceed thirty days.

<b>Product Category</b>	<b>P/N Prefix</b>	<b>Warranty duration</b>
Direct OE Replacement Filters	10, 11, 30, 31, 71, 73	Life of the vehicle
Racing Filters	18	1 year
Universal	21, 24, 72, TF	2 years
Air Intake Systems	50, 51, 54, 55, 75, TR, TA, TL	2 years
Exhaust Systems	49	2 years
Intercoolers & Intercooler Tubes	46-2	2 years
Intake Manifolds	46-1	2 years
Differential Cover	46-7	Life of the vehicle
Exhaust Manifolds	46	2 years
Throttle Body Spacers	46-3	2 years
Turbochargers	46-6	2 years*
Fluid Filters	44	90 days
Pre-Filters	28	2 years
Heavy Duty OE Replacement	70	2 years
PowerSports OE Replacement	81, 87	2 years
PowerSports Intake Systems	85	2 years

No other warranty expressed or implied applies nor is any person or advanced FLOW engineering authorized to assume any other warranty. Some States do not allow the exclusion or limitation of incidental or consequential damages or do not allow limitations on how long an implied warranty lasts, so the above limitations or exclusions may not apply to you. This warranty gives you specific legal rights, and you may also have other rights which vary from State to State.

\*See turbocharger warranty for more info

Feel the difference with aFe.

Buy quality performance air intake systems in our online store.