

**GT**  
**MOMENTUM**

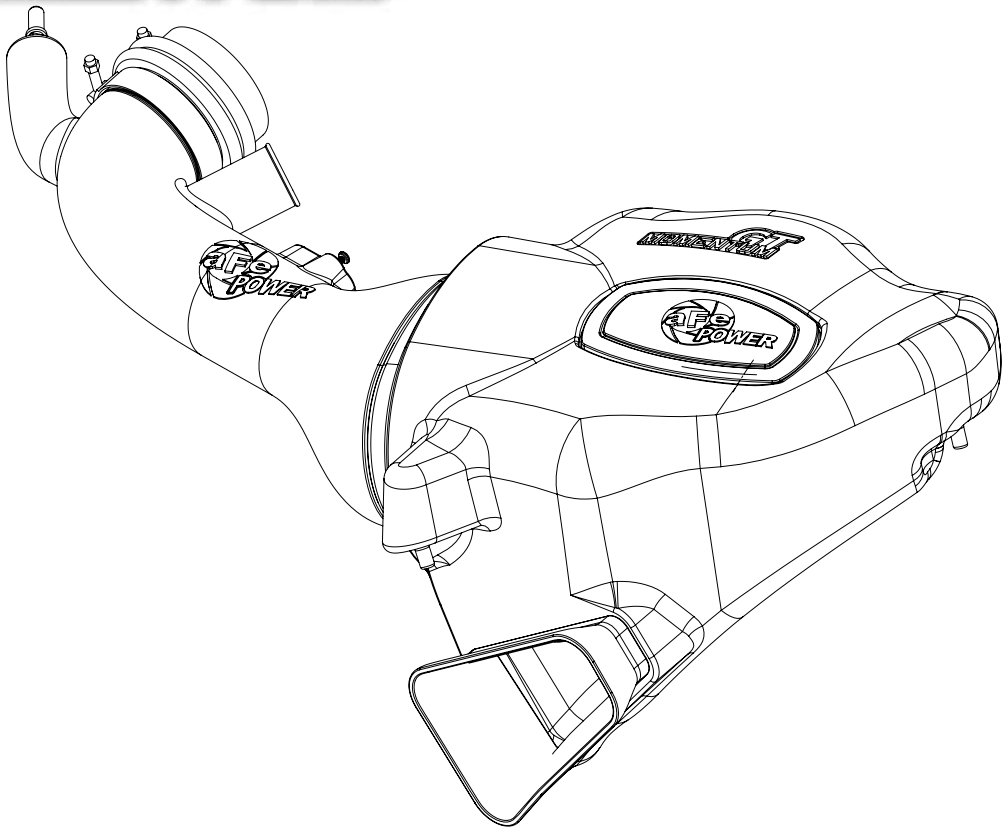

**advanced FLOW engineering** Momentum GT Cold Air Intake System

**Instruction Manual** P/N: 51-74211 / 54-74211

Make: **Chevrolet** Model: **Camaro** Year: **2016-2019** Engine: **V6-3.6L**



- Please read the entire instruction manual before proceeding.
- Ensure all components listed are present.
- If you are missing any of the components, call customer support.
- Ensure you have all necessary tools before proceeding.
- Do not attempt to work on your vehicle when the engine is hot.

## Retain factory parts for future use.

Label	Qty.	Description	Part Number
A1	1	Air Filter (Pro 5R)	24-91092
A2	1	Air Filter (Pro DRY S)	21-91092
B	1	Tube	05-74211B1
C	1	Housing	05-74210B2
D	1	Grommet	03-50139
E	1	Coupling, Silicone	05-01400
F	1	Fitting, Vent	05-01338
G	1	Clamp, T-bolt	05-50320
H	2	Screw, M4	03-50491
I	1	Plug, Urethane	05-00937
J	1	Scoop	05-74210B3
K	1	Adaptor, Billet	05-01096
L	1	Clamp, T-bolt	05-50292

Installation will require the following tools:

8mm nut driver, 11mm deep socket & driver, T20 & T30 Torx, flathead screwdriver, 17mm wrench.

Note: Legal in California for use on race vehicles only. The use of this device on vehicles used on public streets or highways is strictly prohibited in California and others states that have adopted California emission regulations.

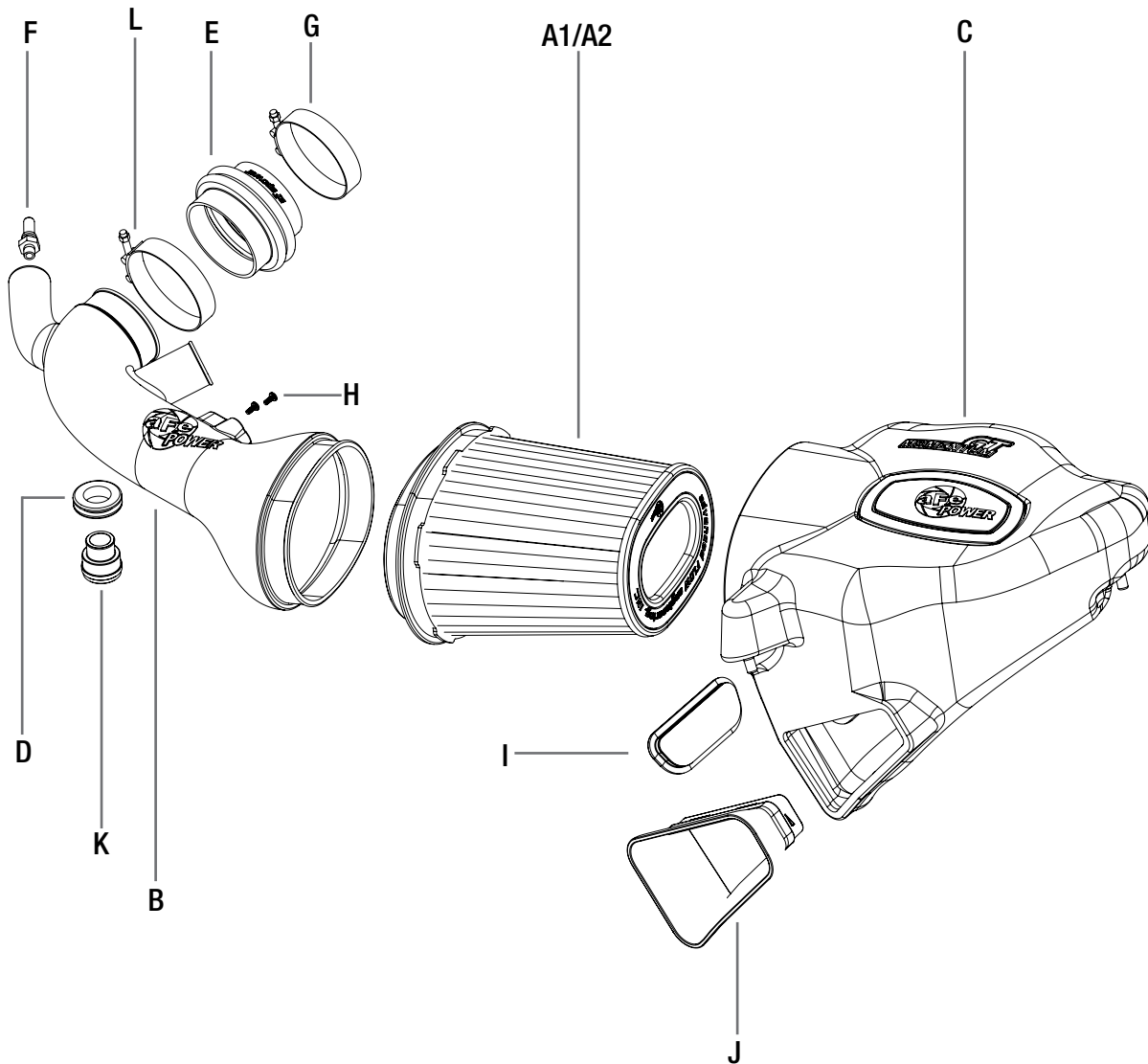

**Figure A****Refer to Figure A for Step 1**

Step 1: Use a T-30 Torx driver to remove the screw (1) holding down the engine cover. Remove the oil cap (2) and remove the engine cover (3). Reinstall the oil cap.



Figure B

**Refer to Figure B for Step 2**

Step 2: Disconnect the sound hose (4) from the bottom of the intake tube.

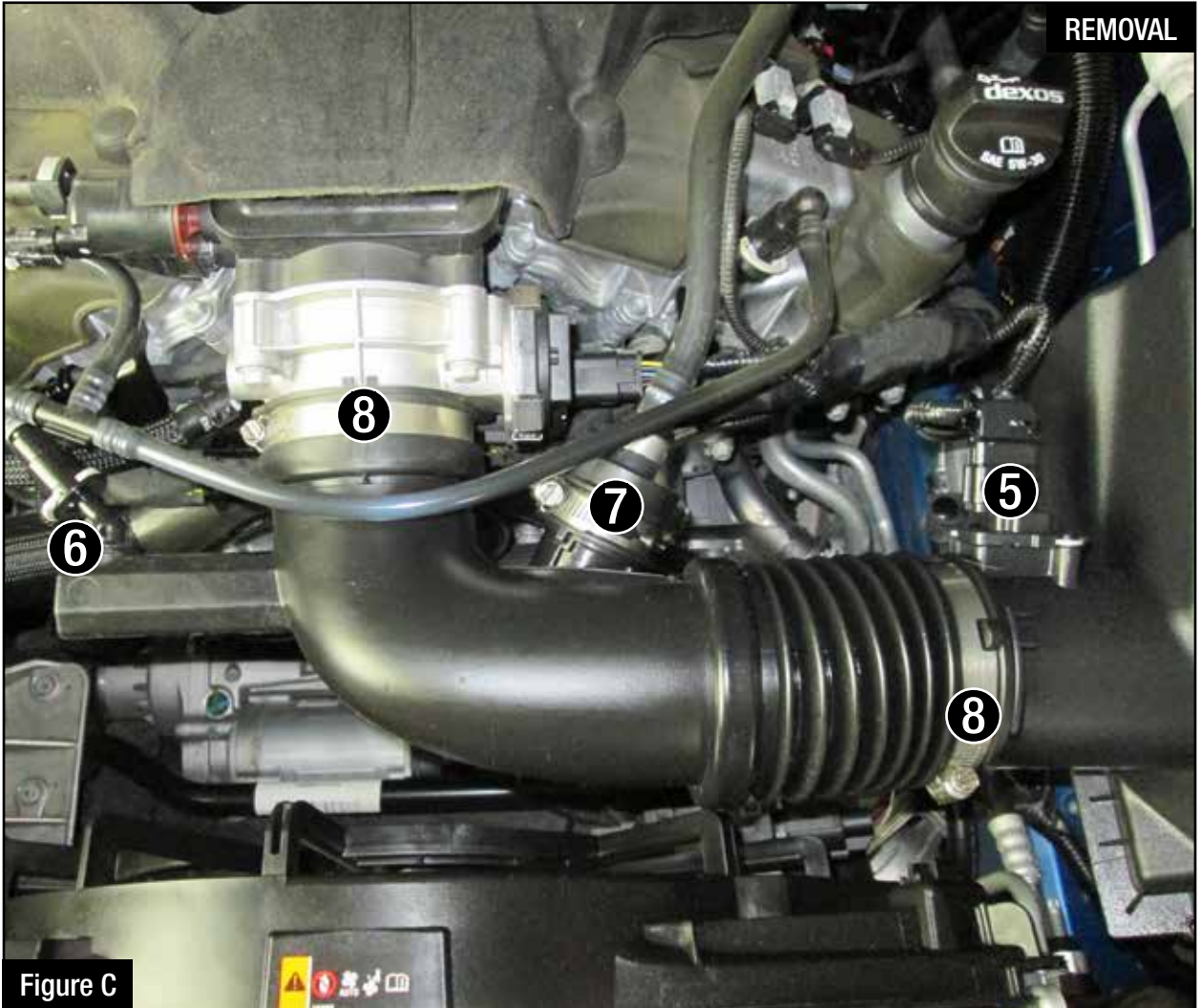
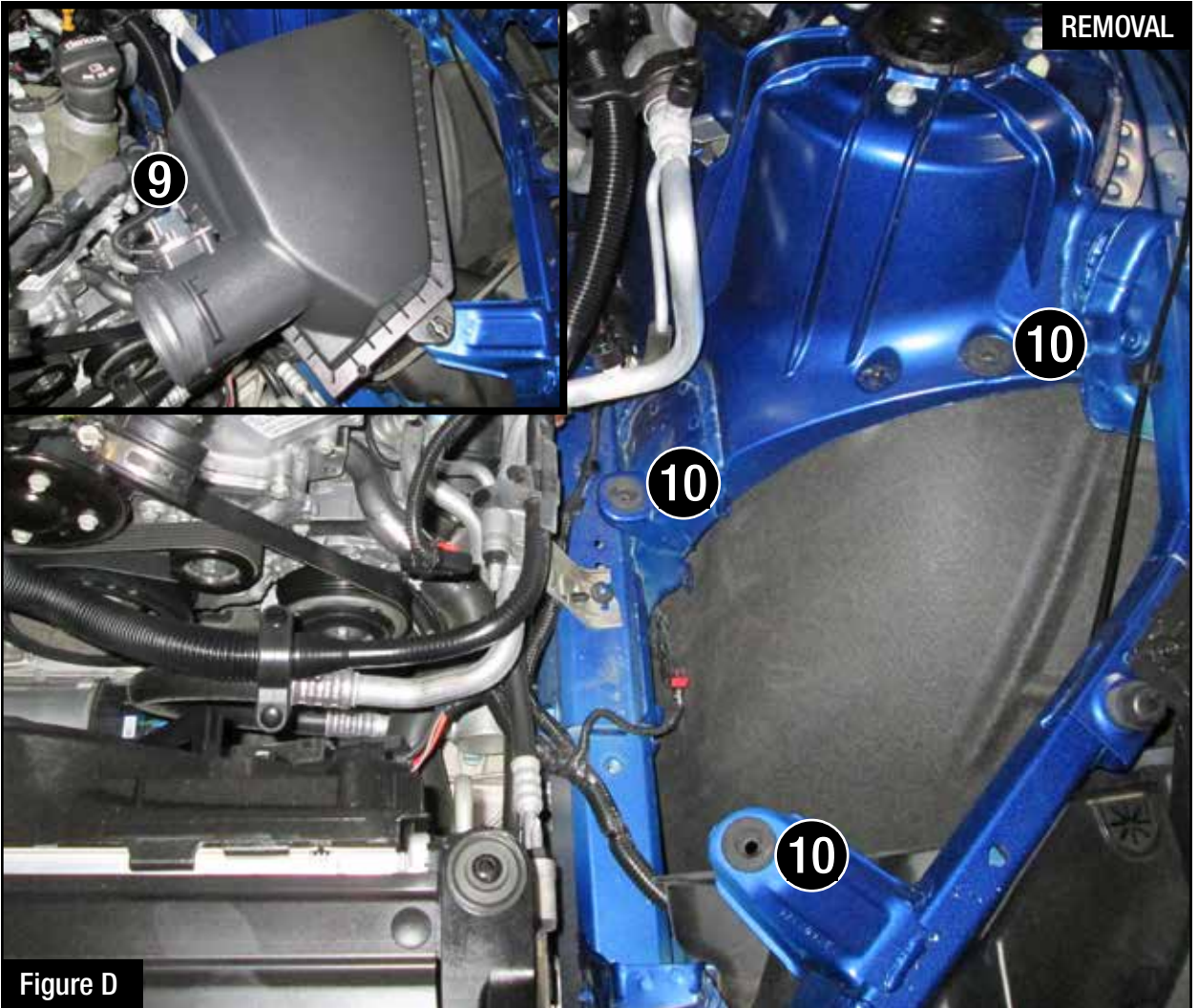

Figure C

**Refer to Figure C for Steps 3-4**

Step 3: Disconnect the MAF sensor (5) and the breather hose (6) from the intake tube. Using an 8mm nut driver, loosen the clamp and remove the PCV hose (7).

Step 4: Use an 8mm nut driver to loosen the stock clamps (8) at the throttle body and the air box. Remove the stock intake tube.



### **Refer to Figure D for Step 5**

Step 5: Using a flat blade screwdriver, disengage the wire loom clip (9) from the air box. Remove the air box by pulling up to release air box from its mounting grommets (10). Make sure the mounting grommets are still in the chassis mounting tabs. If they pulled out and are stuck in the lower half of the air box, remove them from the air box and insert them back on the chassis mounting tabs.



**Refer to Figure E for Steps 6-7**

Step 6: Install the supplied air inlet scoop (11) into the aFe air box.

Step 7: Use the provided plug (12) to close additional air inlet if you want to completely seal the air box.

Best performance gain is obtained by having more air flow (no plug).





Figure F

**Refer to Figure F for Step 8**

Step 8: Slide the aFe filter and clamp into the aFe housing and push it in until it locks into place. Do not tighten the clamp at this time.



Figure G

**Refer to Figure G for Step 9**

Step 9: Install the housing assembly into the vehicle by pushing down air box pins into the rubber grommets. Make sure the pins are completely through the mounting grommets.

INSTALL



Figure H

**Refer to Figure H for Step 10**

Step 10: Using a Torx 20 driver, remove the mass air flow sensor (13) from the upper half of the air box and install it on the aFe intake tube using the two supplied M4 screws. Do not over tighten.



Figure I

**Refer to Figure I for Steps 11-12**

Step 11: Install the supplied aluminum vent fitting (14) into the aFe intake tube using a 17mm wrench.

Step 12: Install the supplied rubber grommet (15) into the aFe intake tube followed by the supplied billet adaptor (16).



### **Refer to Figure J for Step 13**

Step 13: Install the supplied silicone coupler (17) with the smaller supplied T-bolt clamp (18). The smallest I.D. in the coupler goes on the throttle body. Tighten the clamp at the throttle body. Place the larger T-bolt clamp (19) on the coupler but do not tighten at this time.



Figure K

**Refer to Figure K for Step 14**

Step 14: Install the aFe intake tube into the silicone coupler first then into the air filter. Tighten all the clamps.



Figure L

**Refer to Figure L for Step 15**

Step 15: Connect the sound hose (20) onto the billet adapter. Make sure it fully clicks on.



Figure M

**Refer to Figure M for Step 16**

Step 16: Connect the mass air flow sensor (21), breather hose (22) and PCV hose (23).





Figure N

**Refer to Figure N for Step 17**

Step 17: Install the engine cover in reversal of Step 1. Check all the components are tight and secure. Your installation is now complete.

**NOTE: Check all bolts, clamps, and connectors after 200 miles.**



Pro DRY S Air Filter



P/N: 21-91092

Pro 5R Air Filter



P/N: 24-91092

Pre-Filter



P/N: 28-10283

Pro DRY S Restore Kit



P/N: 90-59999

Blue Squeeze Restore Kit



P/N: 90-50501

Sway Bars

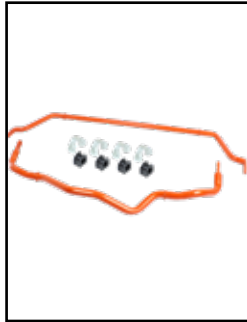

P/N: 440-402002-N

aFe Motorsport T-Shirts



P/N: 40-30441-B (S)  
40-30442-B (M)  
40-30443-B (L)  
40-30444-B (XL)  
40-30445-B (2XL)  
40-30446-B (3XL)