

GT
MOMENTUM™

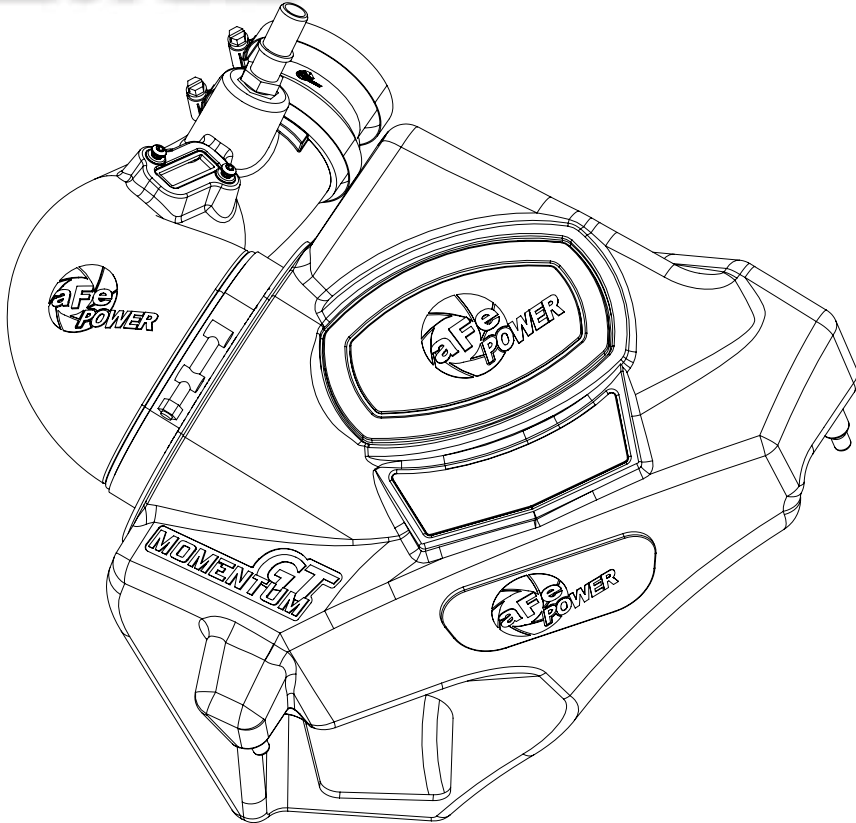

advanced FLOW engineering Momentum GT Cold Air Intake System

Instruction Manual P/N: 51-74209 / 54-74209

Make: **Cadillac** Model: **ATS** Year: **2013-2019** Engine: **L4-2.0L Turbo**



- Please read the entire instruction manual before proceeding.
- Ensure all components listed are present.
- Ensure you have all necessary tools before proceeding.
- Do not attempt to work on your vehicle when the engine is hot.



Retain factory parts for future use.

Label	Qty.	Description	Part Number
A1	1	Air Filter (Pro 5R)	24-91104
A2	1	Air Filter (Pro DRY S)	21-91104
B	1	Tube	05-74209B1
C	1	Housing	05-74205B2
D	1	Clamp, #048	03-50007
E	1	Coupling, Silicone	05-01380
F	1	Fitting, Vent	05-01339
G	1	Clamp, #044	03-50019
H	2	Screw, M4	03-50491
I	1	Plug, Urethane	05-00937
J	1	Small Plug, Silicone	05-01387

Installation will require the following tools:

8mm nut driver, 11mm deep socket & driver, T20 Torx, flathead screwdriver and 20mm wrench or adjustable wrench.

Note: Legal in California for use on race vehicles only. The use of this device on vehicles used on public streets or highways is strictly prohibited in California and others states that have adopted California emission regulations.

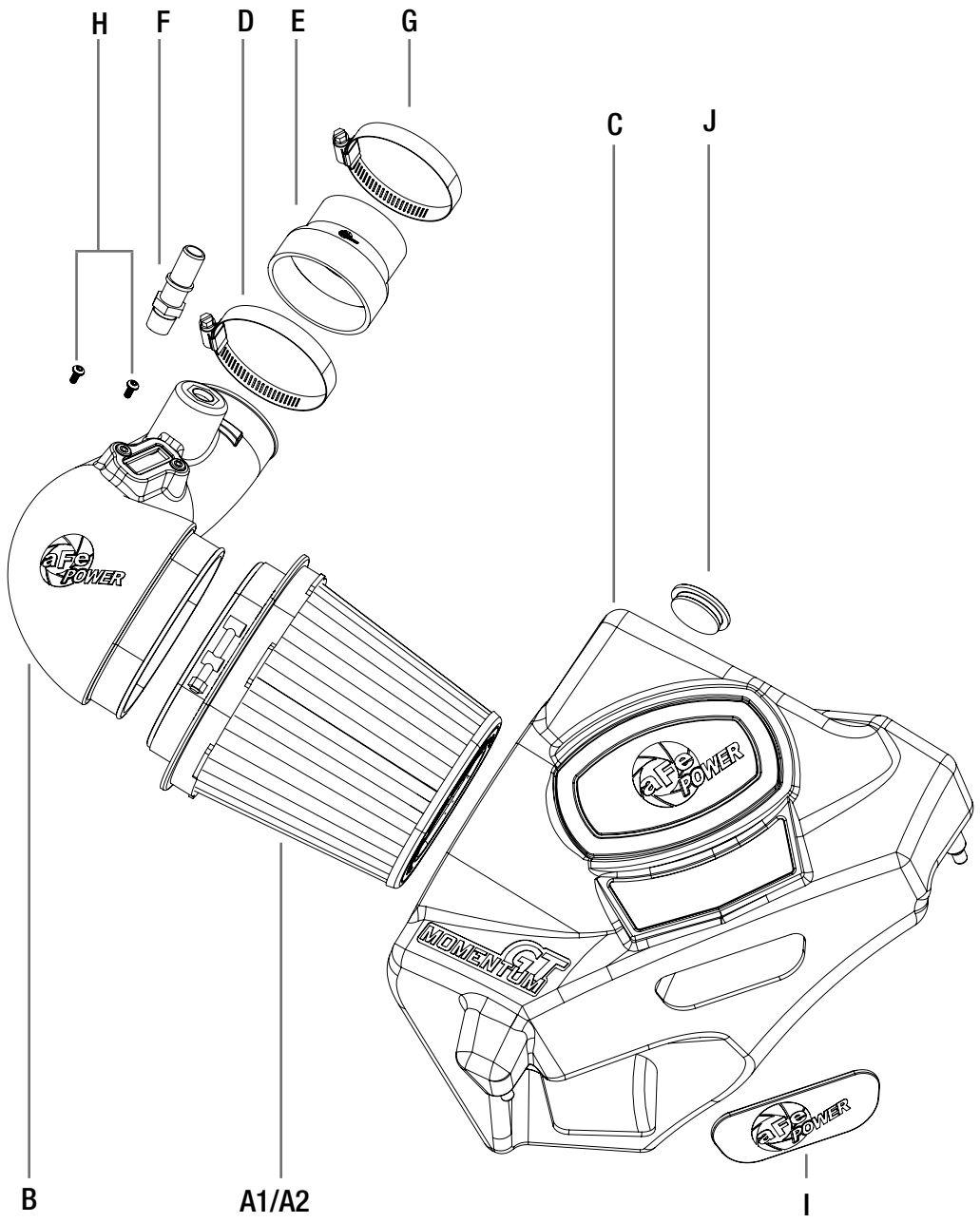



Figure A

Refer to Figure A for Step 1

Step 1: Disconnect the braided hose (1) from the intake tube. Disconnect the MAF (2) sensor and pull off the wire harness clip (3) from the intake tube.



Figure B

Refer to Figure B for Step 2

Step 2: Use an 8mm nut driver to loosen the factory clamps (4) at the turbo and the air box. Remove the factory intake tube.

**Figure C****Refer to Figure C for Step 3**

Step 3: Remove the air box by pulling up to release air box from its mounting grommets (5). Make sure the mounting grommets (5) are still in the chassis mounting tabs. If they pulled out and are stuck in the lower half of the air box, remove them from the air box and insert them back on the chassis mounting tabs.

**Figure D****Refer to Figure D for Step 4**

Step 4: Using a Torx 20 driver remove the mass air flow sensor ⑥ from the upper half of the air box and set it aside.



Figure E

Refer to Figure E for Step 5

Step 5: Remove the plastic air inlet scoop (7) from the lower half of the air box and install into aFe air box.



Figure F

Refer to Figure F for Step 6

Step 6: Install the supplied aFe plug (8) into the air box.



Figure G

Refer to Figure G for Steps 7-8

Step 7: Slide the aFe filter and clamp into the aFe housing and push it in until it locks into place. Do not tighten clamp at this time.

Step 8: Install the housing assembly into the vehicle by pushing down air box pins into the rubber grommets. Make sure the pins are completely through the mounting grommets.



Figure H

Refer to Figure H for Step 9

Step 9: Install the supplied aluminum vent fitting (9) into the aFe intake tube using a 20mm wrench or adjustable wrench. Install the mass air flow sensor (10) on the aFe intake tube using the two supplied M4 screws.



Figure I

Refer to Figure I for Step 10

Step 10: Install the supplied silicone coupler (11) with the supplied small clamp onto the turbo and tighten clamp. Install the supplied large clamp on the coupler.

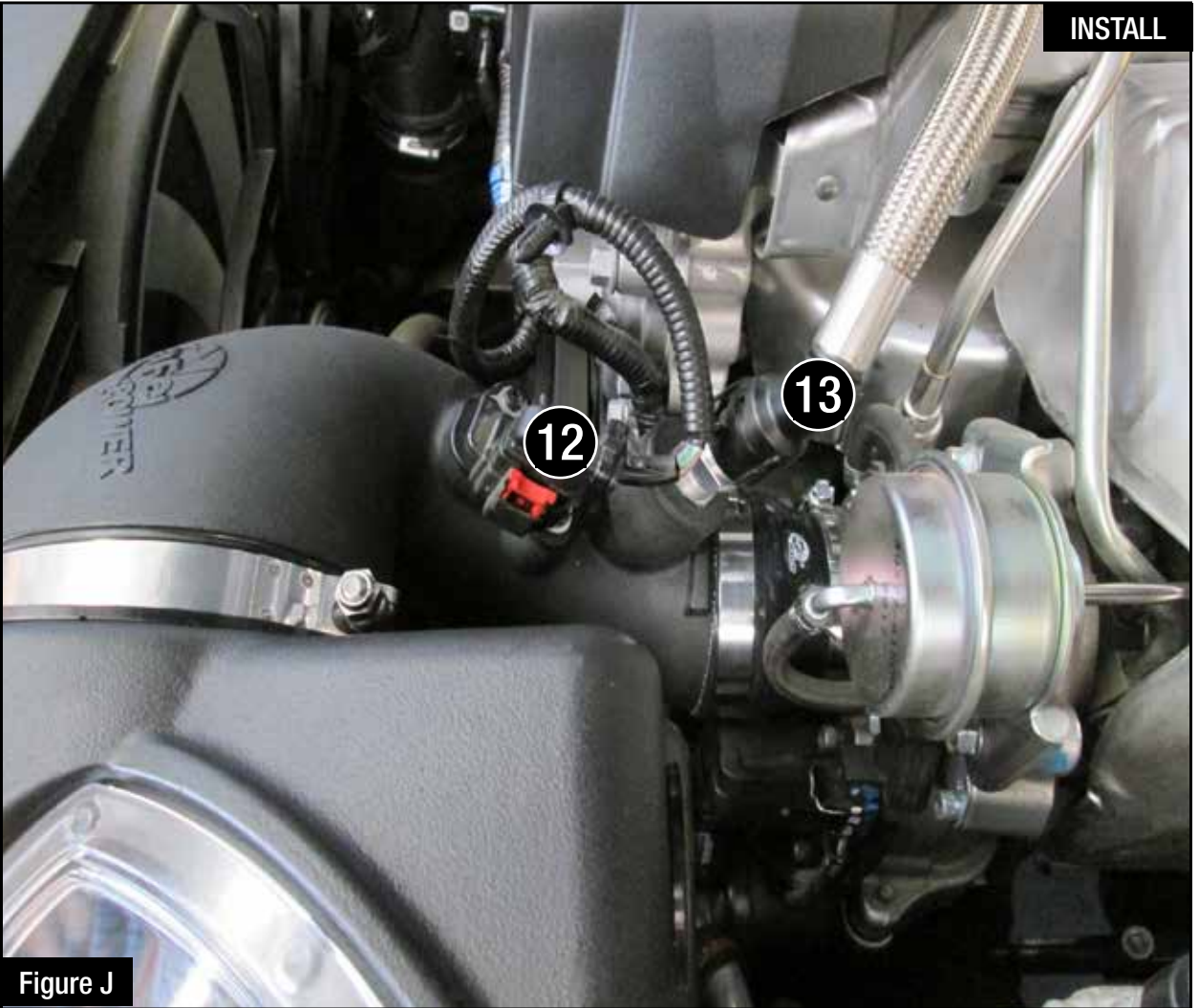

Figure J

Refer to Figure J for Steps 11-12

Step 11: Slide the aFe intake tube into the coupler and then the air filter. Tighten all clamps.

Step 12: Connect the mass air flow sensor (12) and the braided hose (13).

**Figure K**

Step 12: Use the provided plug (14) to close additional air inlet if you want to completely seal the air box. Best performance gain is obtained by having the more flow (no plug). Check all the components are tight and secure. Your installation is now complete.

NOTE: Check all bolts, clamps, and connectors after 200 miles.