

advanced FLOW engineering

Instruction Manual P/N: 52-74202-1 / 51-74202-1 / 54-74202-1

Make: **Chevrolet** Model: **Corvette Z06 (C7)** Year: **2015-2018** Engine: **V8-6.2L (sc) LT4/LT5**



- Please read the entire instruction manual before proceeding.
- Ensure all components listed are present.
- Ensure you have all necessary tools before proceeding.
- Do not attempt to work on your vehicle when the engine is hot.
- Disconnect the negative battery terminal before proceeding.
- Retain factory parts for future use.

Label	Qty.	Description	Part Number
A1	1	Air Filter (Pro DRY S)	21-90088
A2	1	Air Filter (Pro 5R)	24-90088
B	1	Tube	05-74202B1
C	1	Housing	05-74202B2
D	2	Screw, Torx: M4 x .7 x 8mm	03-50491
E	1	Threadlocker	03-50162
F	2	Clamp, T-Bolt (3-3/4 - 4-1/16)	03-50265
G	1	Fitting, Vent Small	05-01338
H	1	Coupling, Silicone Double Hump	05-01375
I	1	Hose, Coolant 3/8" ID (15" inches)	05-01357
J	2	Mini Clamp #006	03-50025
K	1	Ties, Nylon Cable	05-60167

Tools needed: 7mm, 8mm, 10mm and 7/16 Socket or nut driver, Ratchet and extension, flat head screw driver, razor blade, & Torx T20 Driver.

Note: Legal in California for use on race vehicles only. The use of this device on vehicles used on public streets or highways is strictly prohibited in California and others states that have adopted California emission regulations.

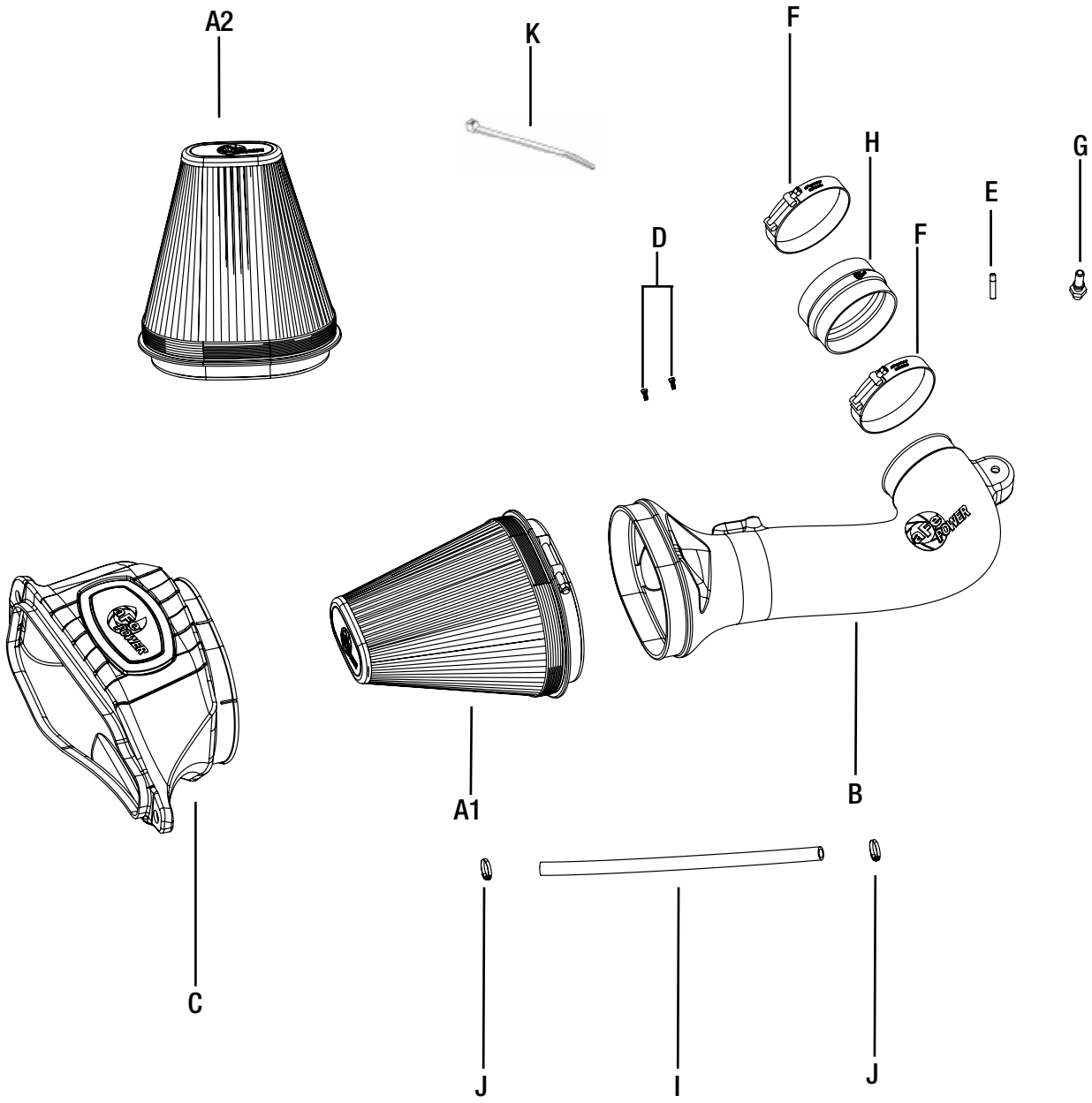

**Figure A****Refer to Figure A for Step 1**

Step 1: Remove the radiator air outlet channel by removing the four screws securing it with a 7mm socket or nut driver.



Figure B

Refer to Figure B for Steps 2-3

Step 2: Disconnect the Mass Air Flow (MAF) Sensor harness.

Step 3: Loosen the clamps at the throttle body and at the housing. Disconnect the vent hose then remove the factory intake tube out of the vehicle.

**Figure C****Refer to Figure C for Step 4**

Step 4: Remove the two 10mm screws holding the factory intake box and pull it out of the mounting grommet then out of the vehicle.



Figure D

Refer to Figure D for Steps 5

Step 5: Unclip wire harness in the location next to the hood strut then move the wire harness out of the way to make room for the aFe air box.



Figure 2



Figure E

Refer to Figure E for Steps 6-7

Step 6: Transfer the three mounting grommet from the factory air box to the aFe Housing.

Step 7: Slide the filter into the housing and install the T-bolt clamps. Do not tighten yet.



Figure F

Refer to Figure F for Step 8

Step 8: Install the aFe filter/housing assembly into the vehicle. Push it on the factory stud and secure it using the two factory 10 mm screws removed at step 4.



Figure G

Refer to Figure G for Steps 9-10

Step 9: Remove the MAF sensor from the factory air box. Install it on the aFe tube using factory O-ring and supplied m4 screws.

Step 10: Screw the provided vent fitting into the aFe tube. Apply some of the furnished threadlocker to guarantee a perfect seal.



Figure H

Refer to Figure H for Steps 11-15

Step 11: Install the silicone coupling over the throttle body.

Step 12: Install the aFe tube into the vehicle. Slide the tube first into the filter then the coupling on the throttle body.

Step 13: Align the tube correctly then install t-bolt clamps over coupling. You may need to open the T-bolt clamps by removing the nut completely. Then install it around the coupling and close it by re-installing the nut. Tighten all clamps.

Step 14: Reconnect the MAF sensor.

Step 15: Connect the vent hose onto the aluminum fitting.

**Figure I****Refer to Figure I for Steps 16-17**

Make sure engine is cold before disconnecting the coolant line.

Step 16: The coolant line needs to be re-routed to make clearance for the hood vent. Locate the short hard plastic coolant line between the check valve and the T-fitting. Put a shop towel under it to catch the coolant excess when disconnected.

Step 17: With a sharp blade, slice open the hard plastic coolant line on both sides and remove it.

**Figure J****Refer to Figure J for Steps 18-20**

Step 18: Replace the hard plastic line with the furnished hose. Install mini clamps on both ends to secure it.

Step 19: Route the hose over the tube like shown in picture. It will seat under the radiator air outlet

Make sure it doesn't kink or put pressure on the MAF sensor. If necessary you can rotate the factory wing clamp.

Step 20: Use the furnished cable tie to secure the coolant line to the vent hose and prevent any contact with the serpentine belt.



Figure K

Refer to Figure K for Steps 21-22

Step 21: Re-install the factory radiator air outlet.

Step 22: Make sure all clamps and connections are secured. Your installation is now completed.

*Verify all connections are secure 100-200 miles after installation



Pro DRY S Air Filter



P/N: 21-90080

Pro 5R Air Filter



P/N: 24-90080

Pro DRY S Restore Kit



P/N: 90-59999

Blue Squeeze Restore Kit



P/N: 90-50501

SCORCHER PRO
Programmer



P/N: 77-34001

Exhaust Connection Pipes



P/N: 48-34130-YC (Street)
48-34130-YN (Race)

Exhaust X-Pipes



P/N: 48-34129-YC (Street)
48-34129-YN (Race)

Axle-Back Exhaust System



P/N: 49-34082-C (C/F Tips)
49-34082-P (Pol. Tips)

Sprint Booster V3



P/N: 77-14006

PFADT Long Tube Headers



P/N: 48C34110

PFADT Sway Bars

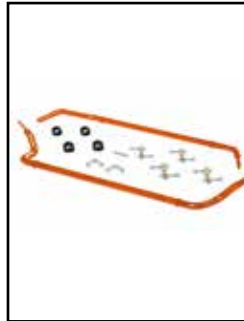

P/N: 440-401003-N (Set)

PFADT Coilovers



P/N: 430-401004-N