

ST
MOMENTUM™

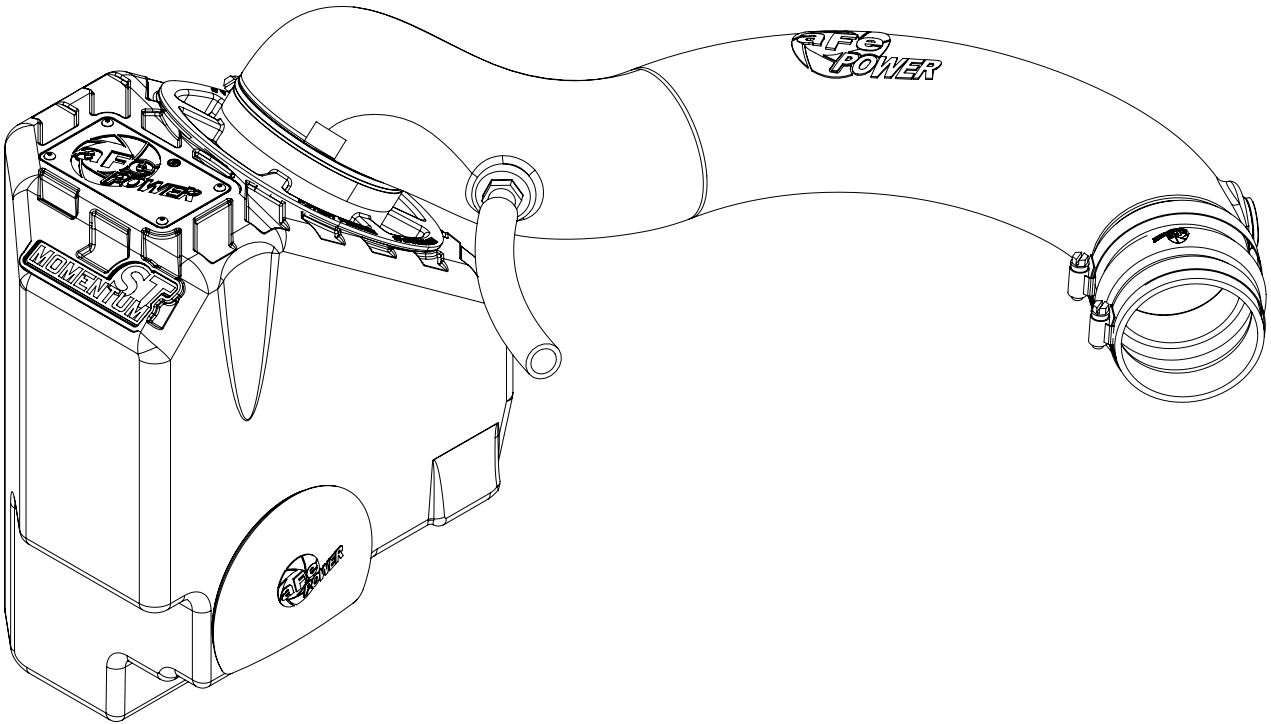

advanced FLOW engineering Momentum ST Intake System

Instruction Manual P/N: 51-46215 / 54-46215 / 75-46215

Make: **Jeep** Model: **Cherokee (KL)** Year: **2014-2018** Engine: **V6-3.2L**



- Please read the entire instruction manual before proceeding.
- Ensure all components listed are present.
- Ensure you have all necessary tools before proceeding.
- Do not attempt to work on your vehicle when the engine is hot.
- Disconnect the negative battery terminal before proceeding.

Retain factory parts for future use.

Label	Qty.	Description	Part Number
A1	1	Air Filter (Pro DRY S)	21-90101
A2	1	Air Filter (Pro 5R)	24-90101
A3	1	Air Filter (Pro-GUARD 7)	72-90101
B	1	Tube	05-01469B1
C	1	Housing	05-01469B2
D	1	Plug, Airbox	05-01192
E	1	Coupling, Silicone Hump Reducer	05-01330
F	1	Hose, Silicone Breather: 1/2"ID (6")	05-01396
G	1	Grommet, Rubber	03-50167
H	2	Clamp, #052	03-50008
I	1	Fitting, Air Temp Sensor	05-01454
J	1	Fitting, Vent Tube (Large)	05-01339

Tools needed: 20mm wrench or adjustable wrench and 8mm nut driver.

Note: Legal in California for use on race vehicles only. The use of this device on vehicles used on public streets or highways is strictly prohibited in California and others states that have adopted California emission regulations.

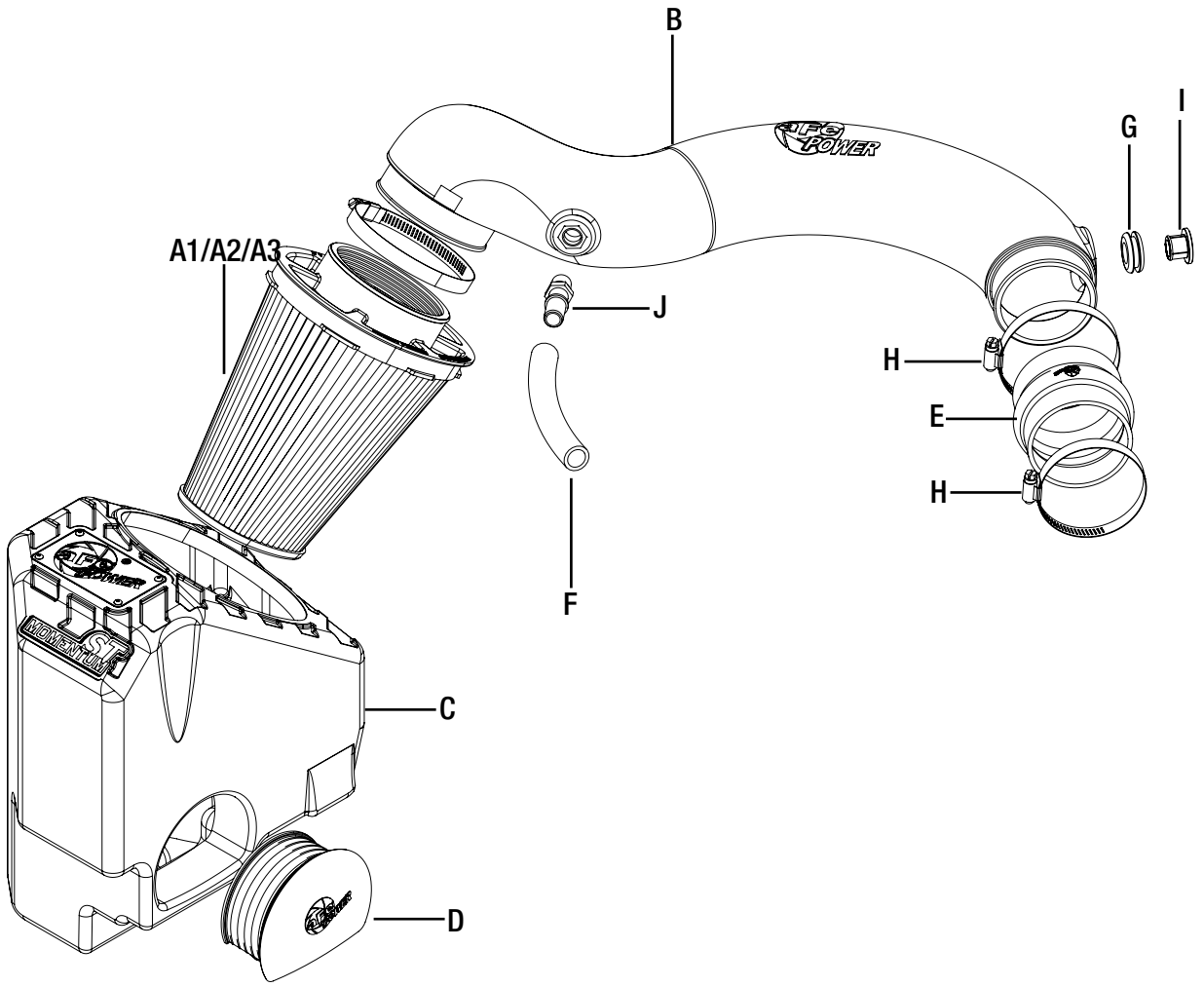



Figure A

Refer to Figure A for Step 1.

Step 1: Remove the engine cover by gently lifting until the mounting grommets disengage. Set the cover aside.



Refer to Figure B for Steps 2-3.

Step 2: Disengage the two wire clips (1) from the stock intake plenum.

Step 3: Disconnect the temperature sensor wire harness (2).

**Figure C****Refer to Figure C for Steps 4-5.**

Step 4: Using an 8mm nut driver, loosen the three clamps (3) at the throttle body, plenum, and stock airbox.

Step 5: Remove the stock intake tube (4) by disengaging first from the plenum, then from the stock airbox.



Figure D

Refer to Figure D for Step 6.

Step 6: Carefully remove the plenum (5) by gently lifting the back end up to disengage from the rear mount, then carefully pulling towards the rear of the vehicle and to the side to disengage from the front mount and throttle body.

NOTE: Lubrication may be required to prevent breaking the plastic mounts.



Figure E

Refer to Figure E for Step 7.

Step 7: Disengage the quick disconnect fitting (6) from the stock airbox by pressing in the grey clip and pulling the fitting away from the housing.



Figure F

Refer to Figure F for Step 8.

Step 8: Remove the stock airbox (7) by pulling it straight up off the mounting grommets.

**Figure G****Refer to Figure G for Step 9.**

Step 9: Remove the quick disconnect fitting and hose (8) from the hard line attached to the intake manifold.

INSTALL



Figure H

Refer to Figure H for Step 10.

Step 10: Remove the plastic quick disconnect fitting (9) from the stock hose and attach it to the supplied length of silicone hose. Reattach the hose to the hard line in the new configuration.



Figure I

Refer to Figure I for Steps 11-13.

Step 11: Remove the three rubber grommets (10) from the stock airbox.

Step 12: Place two of the stock grommets into the aFe airbox in the upper mounting locations. (11)

Step 13: Place the third grommet into the metal mounting bracket in the vehicle. (12)



Figure J

Refer to Figure J for Step 14.

Step 14: (Optional) Use the provided plug ⑬ to close the additional air inlet if you want to completely seal the airbox. Best performance gains are obtained without the plug.



Figure K

Refer to Figure K for Steps 15-16.

Step 15: Install the aFe airbox into the vehicle by lining up the three mounting grommets and gently applying pressure until the grommets lock into place.

Step 16: Install your aFe air filter into the airbox.



Figure L

Refer to Figure L for Step 17.

Step 17: Install the supplied 3/8 NPT fitting (14) into the threaded insert on the aFe intake tube. Hand tighten using a 20mm wrench or adjustable wrench.

**Figure M****Refer to Figure M for Step 18.**

Step 18: Install the supplied grommet and sensor fitting (15) into the aFe intake tube, then transfer the temperature sensor (16) from the stock plenum into the aFe intake tube.



Figure N

Refer to Figure N for Steps 19-20.

- Step 19: Install the aFe silicone reducer coupler and clamps (17) into the vehicle with the smaller side on the throttle body. Tighten only the clamp on the throttle body (18) with an 8mm nut driver at this time.
- Step 20: Disengage the two temperature sensor harness clips (19) to allow the harness to extend to its new location.

**Figure 0****Refer to Figure 0 for Step 21.**

Step 21: Install your aFe intake tube into the vehicle by inserting the smaller end into the coupler on the throttle body, then rotating the tube down into the air filter. Tighten the clamps at the air filter (20) and silicone coupling (21) using an 8mm nut driver



Figure P

Refer to Figure P for Steps 22-23.

Step 22: Reattach the quick disconnect fitting (22) to the aFe intake tube.

Step 23: Reconnect the temperature sensor wire harness (23) to the temperature sensor.

**Figure Q****Refer to Figure Q for Step 24.**

Step 24: Reinstall the engine cover by lining up the mounting grommets and applying light pressure until they clip into place. Check that all components are tight and secure. Your installation is now complete. Thank you for choosing aFe POWER!

NOTE: Check all bolts, clamps, and hose connections after 100-200 miles.