

advanced FLOW engineering Momentum ST Intake System
Instruction Manual P/N: 51-46209 / 54-46209 / 75-46209

Make: **Jeep** Model: **Cherokee (XJ)** Year: **1991-2001** Engine: **I6-4.0L**



- Please read the entire instruction manual before proceeding.
- Ensure all components listed are present.
- Ensure you have all necessary tools before proceeding.
- Do not attempt to work on your vehicle when the engine is hot.
- Disconnect the negative battery terminal before proceeding.

Retain factory parts for future use.

Label	Qty.	Description	Part Number
A1	1	Air Filter (Pro DRY S)	21-90099
A2	1	Air Filter (Pro 5R)	24-90099
A3	1	Air Filter (Pro-GUARD 7)	72-90099
B	1	Tube	05-01467B1
C	1	Housing	05-01467B2
D	1	Plug, Airbox	05-00937
E	1	Coupling, Elbow Reducer	05-01009
F	1	Hose, Silicone Breather: 1/2" (5")	05-01396
G	3	Grommet, Rubber	03-50076
H	2	Clamp. #048	03-50007

Tools needed: Flat Head Screwdriver, 13mm deep socket or extension, 8mm nut driver, and ratchet wrench.

Note: Legal in California for use on race vehicles only. The use of this device on vehicles used on public streets or highways is strictly prohibited in California and others states that have adopted California emission regulations.

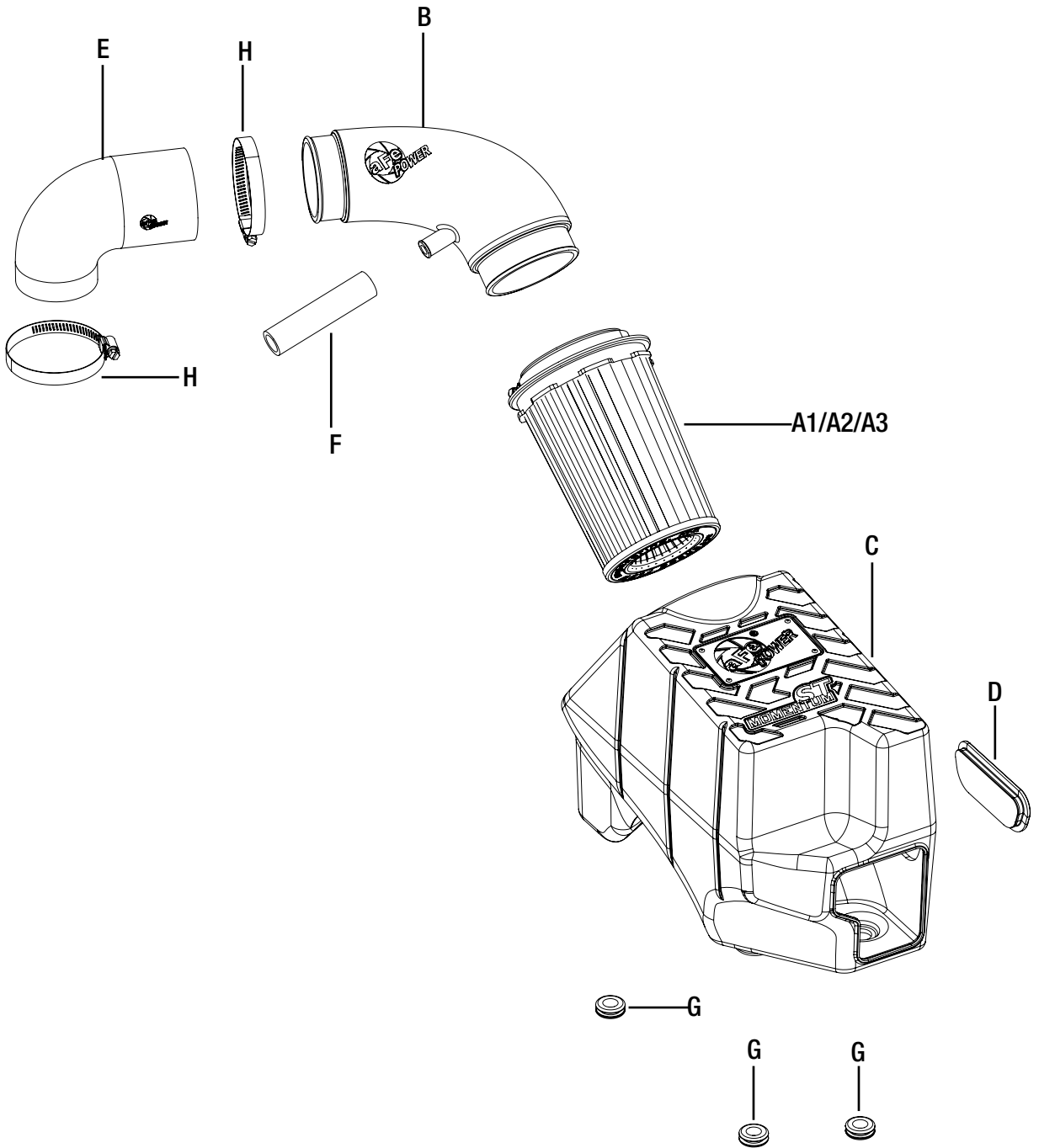

**Figure A****Refer to Figure A for Steps 1-2**

Step 1: Disconnect the PCV hose (1) from the stock intake housing and move it to the side.

Step 2: Using a flathead screwdriver, disconnect the two clamps (2) on the stock intake tube and remove the tube from the vehicle.



Figure B

Refer to Figure B for Steps 3-4

Step 3: Remove the top of the airbox by un-locking the four tabs (3) on the side of the airbox.

Step 4: Remove the stock air filter (4) and place it to the side



Refer to Figure C for Steps 5-6

Step 5: Using a 13mm socket, remove the two bolts and nut ⑤ from the bottom of the airbox and put them to the side for later use.

Step 6: Remove the stock airbox from the vehicle and place it to the side.



Figure D

Refer to Figure D for Steps 7-10

Step 7: Install the three supplied grommets (6) into the aFe Power airbox (7).

Step 8: Place the airbox into the vehicle and position the holes to line them up with the stock fender.

Step 9: Using the nut you removed in Step 5, secure the airbox by locating it on the rear mounting stud and hand tightening the nut on it. Then align the front mounting points and secure the airbox using the remaining hardware.

Step 10: Place the filter (8) into the housing and make sure it is secure.

**Figure E****Refer to Figure E for Steps 11-14**

- Step 11: Place the coupler (9) onto the smaller end of the tube and slip the supplied worm-clamps (10) over the coupler. (The order of the worm clamps do not matter)
- Step 12: Ensure that the worm clamp (11) supplied on the filter is loose.
- Step 13: Insert the larger end of the tube (12) into the filter flange, but DO NOT tighten the worm clamp.
- Step 14: Slip the other end of the coupler (13) over the throttle body.

**Figure F****Refer to Figure F for Steps 15-17**

Step 15: Move one of the clamps (14) down to the throttle body and tighten it with an 8mm nut driver.

Step 16: Tighten the second clamp (15) where the coupler meets the intake tube.

Step 17: Now tighten the clamp (16) on the filter.

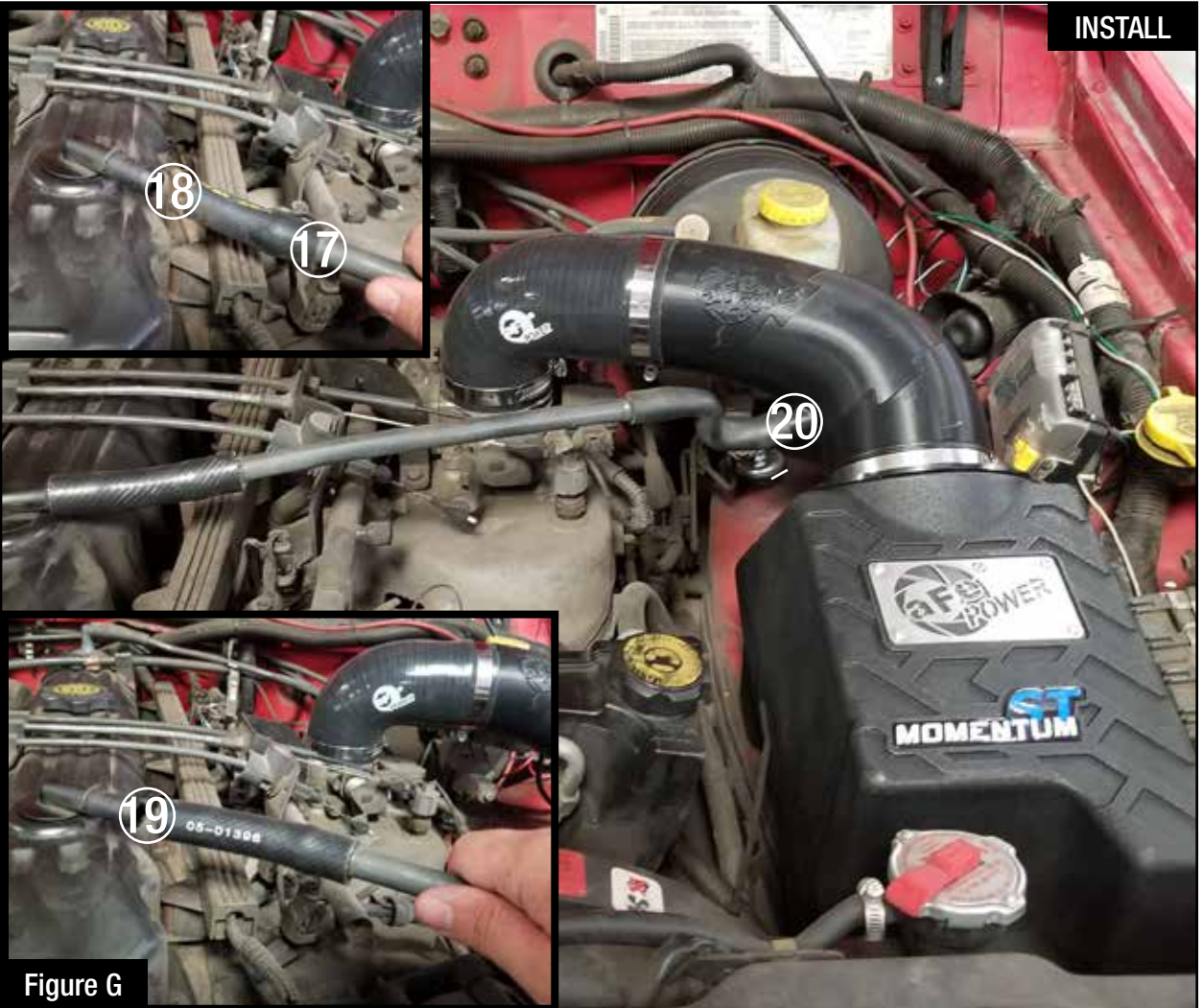
Figure G
Refer to Figure G for Steps 18-20

- Step 18: Remove the stock PCV line (17) from the fitting on the top of the valve cover then remove the stock rubber hose (18).
- Step 19: Install the supplied hose (19) between the stock PCV hard-line and the fitting on top of the valve cover, then install the other end of the line (20) over the fitting on the intake tube.
- Step 20: Make sure all clamps and hose connections are secured. Your installation is now complete! Thank you for choosing aFe POWER.

NOTE: Check all bolts, clamps, and hose connections after 100-200 miles.